

PACIFIC NORTHWEST STRUCTURAL GROUP, INC.

6193 NE MALBON CT.
KINGSTON, WA 98346
(360) 903-2803
David@PNWStructure.com

STRUCTURAL CALCULATIONS

21-028 SMITH-CUTRIGHT RESIDENCE ADDITION & REMODEL
7655 SE 40TH STREET
MERCER ISLAND, WA 98040

ALL COMPUTATIONS AND ENGINEERING FOR THIS PROJECT HAVE
BEEN PERFORMED BY MYSELF OR UNDER MY SUPERVISION.

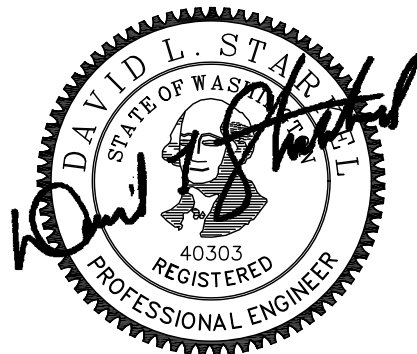

18-OCT-21

DIGITAL SIGNATURE

DIGITAL SIGNATURE

ASCE 7 Hazards Report

Address:
7655 SE 40th St
Mercer Island, Washington
98040

Standard: ASCE/SEI 7-16
Risk Category: II
Soil Class: D - Default (see Section 11.4.3)

Elevation: 198.09 ft (NAVD 88)
Latitude: 47.57438
Longitude: -122.235437

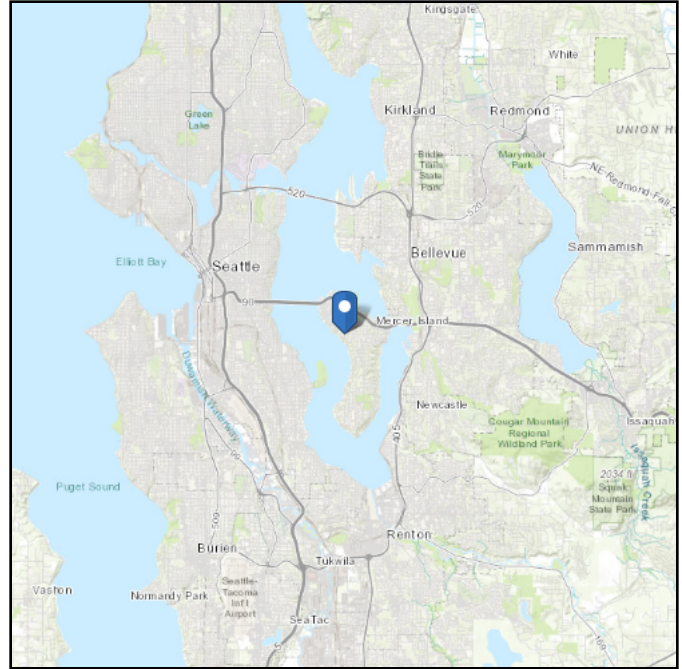
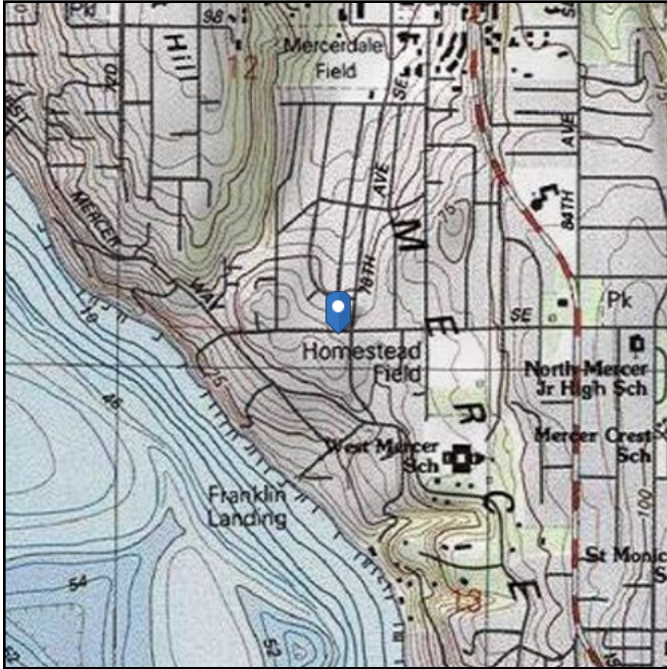

Wind

Results:

Wind Speed:	98 Vmph
10-year MRI	67 Vmph
25-year MRI	74 Vmph
50-year MRI	78 Vmph
100-year MRI	83 Vmph

Data Source: ASCE/SEI 7-16, Fig. 26.5-1B and Figs. CC.2-1–CC.2-4, and Section 26.5.2
Date Accessed: Sun Oct 17 2021

Value provided is 3-second gust wind speeds at 33 ft above ground for Exposure C Category, based on linear interpolation between contours. Wind speeds are interpolated in accordance with the 7-16 Standard. Wind speeds correspond to approximately a 7% probability of exceedance in 50 years (annual exceedance probability = 0.00143, MRI = 700 years).

Site is not in a hurricane-prone region as defined in ASCE/SEI 7-16 Section 26.2.

Site Soil Class: D - Default (see Section 11.4.3)

Results:

S_s :	1.418	S_{D1} :	N/A
S_1 :	0.493	T_L :	6
F_a :	1.2	PGA :	0.607
F_v :	N/A	PGA _M :	0.728
S_{MS} :	1.702	F_{PGA} :	1.2
S_{M1} :	N/A	I_e :	1
S_{DS} :	1.135	C_v :	1.384

Ground motion hazard analysis may be required. See ASCE/SEI 7-16 Section 11.4.8.

Data Accessed: Sun Oct 17 2021

Date Source: [USGS Seismic Design Maps](#)

Snow

Results:

Elevation:

Data Source:

Date Accessed: Sun Oct 17 2021

In "Case Study" areas, site-specific case studies are required to establish ground snow loads. Extreme local variations in ground snow loads in these areas preclude mapping at this scale.

Ground snow load determination for such sites shall be based on an extreme value statistical analysis of data available in the vicinity of the site using a value with a 2 percent annual probability of being exceeded (50-year mean recurrence interval).

Site is outside ASCE/SEI 7-16, Table 7.2-5 boundaries. For ground snow loads in this area, see SEAW Snow Load Analysis for Washington, 2nd Ed. (1995). [Structural Engineers Association of Washington](#), Seattle, WA.

Statutory requirements of the Authority Having Jurisdiction are not included.

The ASCE 7 Hazard Tool is provided for your convenience, for informational purposes only, and is provided "as is" and without warranties of any kind. The location data included herein has been obtained from information developed, produced, and maintained by third party providers; or has been extrapolated from maps incorporated in the ASCE 7 standard. While ASCE has made every effort to use data obtained from reliable sources or methodologies, ASCE does not make any representations or warranties as to the accuracy, completeness, reliability, currency, or quality of any data provided herein. Any third-party links provided by this Tool should not be construed as an endorsement, affiliation, relationship, or sponsorship of such third-party content by or from ASCE.

ASCE does not intend, nor should anyone interpret, the results provided by this Tool to replace the sound judgment of a competent professional, having knowledge and experience in the appropriate field(s) of practice, nor to substitute for the standard of care required of such professionals in interpreting and applying the contents of this Tool or the ASCE 7 standard.

In using this Tool, you expressly assume all risks associated with your use. Under no circumstances shall ASCE or its officers, directors, employees, members, affiliates, or agents be liable to you or any other person for any direct, indirect, special, incidental, or consequential damages arising from or related to your use of, or reliance on, the Tool or any information obtained therein. To the fullest extent permitted by law, you agree to release and hold harmless ASCE from any and all liability of any nature arising out of or resulting from any use of data provided by the ASCE 7 Hazard Tool.

Pacific Northwest Structural Group

6193 NE Malbon Ct.
Kingston, WA 98346
(360) 903.2803

JOB TITLE Smith-Cutright Residence Addition & Rem

JOB NO.	21-028	SHEET NO.	
CALCULATED BY	DLS	DATE	
CHECKED BY	DLS	DATE	

Wind Loads :

ASCE 7- 16

Ultimate Wind Speed	110 mph
Nominal Wind Speed	85.2 mph
Risk Category	II
Exposure Category	B
Enclosure Classif.	Enclosed Building
Internal pressure	+/-0.18
Directionality (Kd)	0.85
Kh case 1	0.701
Kh case 2	0.677
Type of roof	Sawtooth

Topographic Factor (Kzt)

Topography	Flat
Hill Height (H)	30.0 ft
Half Hill Length (Lh)	15.0 ft
Actual H/Lh =	0.00
Use H/Lh =	0.00
Modified Lh =	15.0 ft
From top of crest: x =	50.0 ft
Bldg up/down wind?	downwind

H/Lh= 0.00	$K_1 = 0.000$
x/Lh = 3.33	$K_2 = 0.000$
z/Lh = 1.78	$K_3 = 1.000$

At Mean Roof Ht:

$$Kzt = (1+K_1K_2K_3)^2 = 1.00$$

H < 60ft; exp B
∴ Kzt=1.0

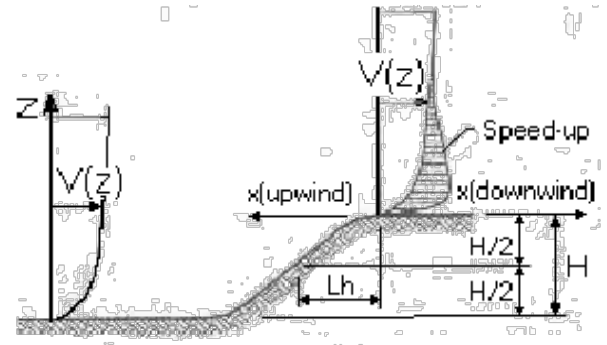

ESCARPMENT

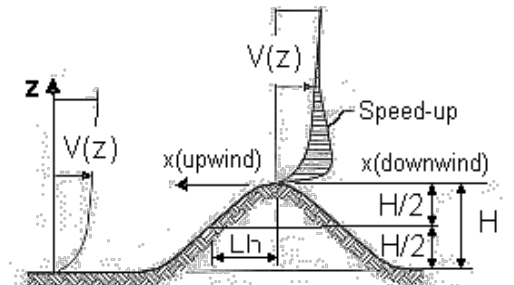

2D RIDGE or 3D AXISYMMETRICAL HILL

Gust Effect Factor

h =	26.6 ft
B =	49.5 ft
/z (0.6h) =	30.0 ft

Flexible structure if natural frequency < 1 Hz (T > 1 second).

If building h/B>4 then may be flexible and should be investigated.

h/B = 0.54 Rigid structure (low rise bldg)

G = 0.85 Using rigid structure default

Rigid Structure

\bar{e} =	0.33
l =	320 ft
Z_{min} =	30 ft
c =	0.30
g_Q, g_v =	3.4
L_z =	310.0 ft
Q =	0.89
I_z =	0.30
G =	0.86 use G = 0.85

Flexible or Dynamically Sensitive Structure

$34 \text{ rcy } (\eta_1)$ =	0.0 Hz		
Damping ratio (β) =	0		
γ/b =	0.45		
γ/α =	0.25		
V_z =	70.9		
N_1 =	0.00		
R_n =	0.000	$\eta =$	0.000
R_B =	28.282	$\eta =$	0.000
R_L =	28.282	$\eta =$	0.000
g_R =	0.000		
R =	0.000		
Gf =	0.000		

h = 26.6 ft

Enclosure Classification

Pacific Northwest Structural Group

6193 NE Malbon Ct.
Kingston, WA 98346
(360) 903.2803

JOB TITLE Smith-Cutright Residence Addition & Rem

JOB NO. 21-028 SHEET NO. _____
CALCULATED BY DLS DATE _____
CHECKED BY DLS DATE _____

Test for Enclosed Building: $A_o < 0.01A_g$ or 4 sf, whichever is smaller

Test for Open Building: All walls are at least 80% open.
 $A_o \geq 0.8A_g$

Test for Partially Enclosed Building: Predominately open on one side only

Input			Test	
Ao	100.0 sf		$A_o \geq 1.1A_{oi}$	NO
Ag	100.0 sf		$A_o > 4'$ or $0.01A_g$	YES
Aoi	100.0 sf		$A_{oi} / A_{gi} \leq 0.20$	NO
Agi	100.0 sf			

Building is NOT Partially Enclosed

Conditions to qualify as Partially Enclosed Building. Must satisfy all of the following:

- $A_o \geq 1.1A_{oi}$
- $A_o >$ smaller of 4' or $0.01 A_g$
- $A_{oi} / A_{gi} \leq 0.20$

Where:

- A_o = the total area of openings in a wall that receives positive external pressure.
- A_g = the gross area of that wall in which A_o is identified.
- A_{oi} = the sum of the areas of openings in the building envelope (walls and roof) not including A_o .
- A_{gi} = the sum of the gross surface areas of the building envelope (walls and roof) not including A_g .

Test for Partially Open Building: A building that does not qualify as open, enclosed or partially enclosed.
(This type building will have same wind pressures as an enclosed building.)

Reduction Factor for large volume partially enclosed buildings (Ri) :

If the partially enclosed building contains a single room that is unpartitioned , the internal pressure coefficient may be multiplied by the reduction factor R_i .

Total area of all wall & roof openings (A_{og}):	0 sf
Unpartitioned internal volume (V_i) :	0 cf
$R_i =$	1.00

Ground Elevation Factor (Ke)

Grd level above sea level =	0.0 ft		$K_e =$	1.0000
Constant =	0.00256	Adj Constant =	0.00256	

Pacific Northwest Structural Group

6193 NE Malbon Ct.
Kingston, WA 98346
(360) 903.2803

JOB TITLE Smith-Cutright Residence Addition & Remodel

JOB NO. 21-028 SHEET NO. _____
CALCULATED BY DLS DATE _____
CHECKED BY DLS DATE _____

Wind Loads - MWFRS $h \leq 60'$ (Low-rise Buildings) except for open buildings

$K_z = K_h$ (case 1) = 0.70
Base pressure (qh) = **18.4 psf**
GCpi = +/-0.18

Edge Strip (a) = 4.6 ft
End Zone (2a) = 9.1 ft
Zone 2 length = 22.8 ft

Wind Pressure Coefficients

Surface	CASE A $\theta = 9.5 \text{ deg}$			CASE B		
	GCpf	w/-GCpi	w/+GCpi	GCpf	w/-GCpi	w/+GCpi
1	0.44	0.62	0.26	-0.45	-0.27	-0.63
2	-0.69	-0.51	-0.87	-0.69	-0.51	-0.87
3	-0.40	-0.22	-0.58	-0.37	-0.19	-0.55
4	-0.33	-0.15	-0.51	-0.45	-0.27	-0.63
5				0.40	0.58	0.22
6				-0.29	-0.11	-0.47
1E	0.67	0.85	0.49	-0.48	-0.30	-0.66
2E	-1.07	-0.89	-1.25	-1.07	-0.89	-1.25
3E	-0.58	-0.40	-0.76	-0.53	-0.35	-0.71
4E	-0.49	-0.31	-0.67	-0.48	-0.30	-0.66
5E				0.61	0.79	0.43
6E				-0.43	-0.25	-0.61

Ultimate Wind Surface Pressures (psf)

1	11.4	4.8	-5.0	-11.6
2	-9.4	-16.0	-9.4	-16.0
3	-4.1	-10.7	-3.5	-10.1
4	-2.8	-9.4	-5.0	-11.6
5			10.7	4.1
6			-2.0	-8.7
1E	15.6	9.0	-5.5	-12.2
2E	-16.4	-23.1	-16.4	-23.1
3E	-7.3	-14.0	-6.5	-13.1
4E	-5.8	-12.4	-5.5	-12.2
5E			14.6	7.9
6E			-4.6	-11.3

Parapet

Windward parapet = 0.0 psf (GCpn = +1.5)
Leeward parapet = 0.0 psf (GCpn = -1.0)

Windward roof overhangs = 12.9 psf (upward) add to windward roof pressure

Horizontal MWFRS Simple Diaphragm Pressures (psf)

Transverse direction (normal to L)

Interior Zone: Wall 14.2 psf
Roof -5.3 psf **
End Zone: Wall 21.4 psf
Roof -9.1 psf **

Longitudinal direction (parallel to L)

Interior Zone: Wall 12.7 psf
End Zone: Wall 19.2 psf

** NOTE: Total horiz force shall not be less than that determined by neglecting roof forces (except for MWFRS moment frames).

The code requires the MWFRS be designed for a min ultimate force of 16 psf multiplied by the wall area plus an 8 psf force applied to the vertical projection of the roof.

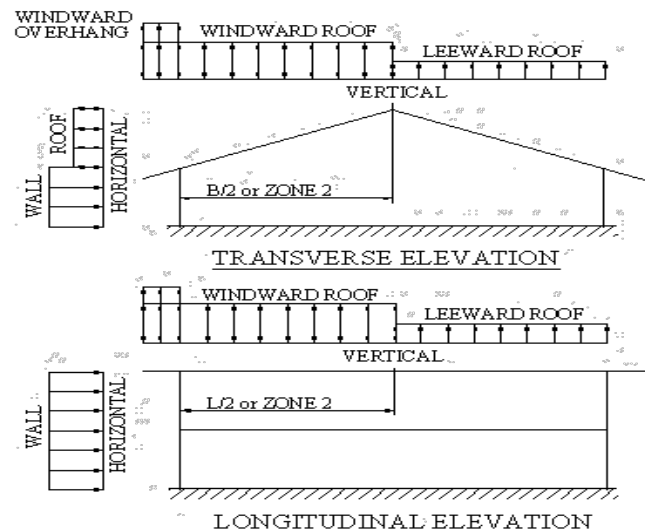

Wind Loads - $h \leq 60'$ Longitudinal Direction MWFRS On Open or Partially

Enclosed Buildings with Transverse Frames and Pitched Roofs

Base pressure (qh) = **18.4 psf**
GCpi = +/-0.18 Enclosed bldg, procdure doesn't apply
Roof Angle (θ) = 9.5 deg

ASCE 7-16 procedure

Pacific Northwest Structural Group

6193 NE Malbon Ct.
 Kingston, WA 98346
 (360) 903.2803

JOB TITLE Smith-Cutright Residence Addition & Remodel

JOB NO. <u>21-028</u>	SHEET NO. _____
CALCULATED BY <u>DLS</u>	DATE _____
CHECKED BY <u>DLS</u>	DATE _____

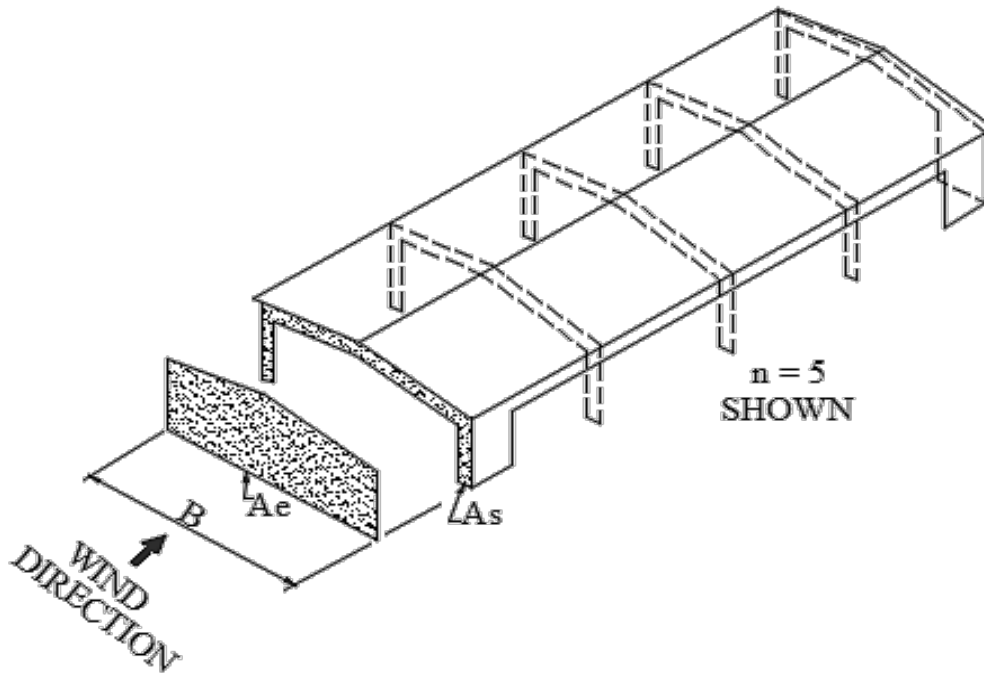

B =	49.5 ft
# of frames (n) =	5
Solid area of end wall including fascia (As) =	1,500.0 sf
Roof ridge height =	30.8 ft
Roof eave height =	26.6 ft
Total end wall area if solid (Ae) =	1,420.8 sf

Longitudinal Directional Force (F) = pAe
 $p = qh [(GC_{pf})_{windward} - (GC_{pf})_{leeward}] K_B K_S$

Solidarity ratio (Φ) =	1.056
n =	5
KB =	0.8
KS =	2.124
Zones 5 & 6 area =	1,295 sf
5E & 6E area =	126 sf
(GC _{pf}) windward - (GC _{pf}) leeward] =	0.721
p =	22.6 psf

Total force to be resisted by MWFRS (F) = **32.1 kips** applied at the centroid of the end wall area Ae

Note: The longitudinal force acts in combination with roof loads calculated elsewhere for an open or partially enclosed building.

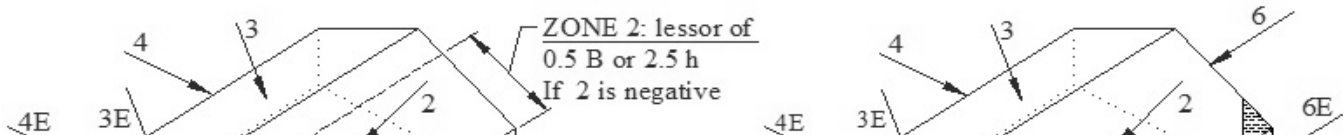

Pacific Northwest Structural Group

6193 NE Malbon Ct.
 Kingston, WA 98346
 (360) 903.2803

JOB TITLE Smith-Cutright Residence Addition & Remodel

JOB NO. 21-028
 CALCULATED BY DLS
 CHECKED BY DLS

SHEET NO. _____
 DATE _____
 DATE _____

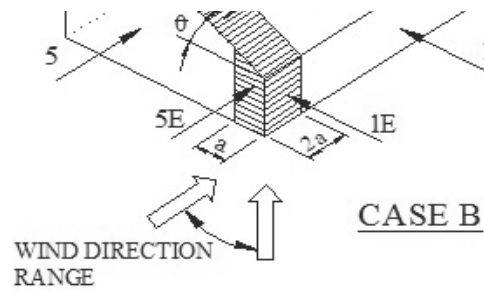
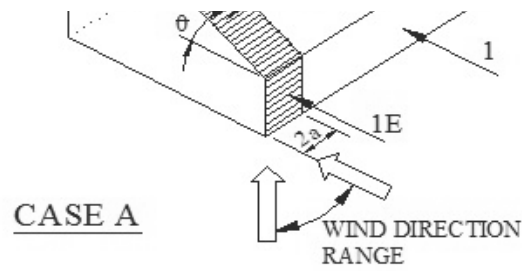

NOTE: Torsional loads are 25% of zones 1 - 6. See code for loading diagram.
 Exception: One story buildings $h < 30'$ and 1 to 2 story buildings framed with light-frame construction or with flexible diaphragms need not be designed for the torsional load case.

ASCE 7-98 & ASCE 7-10 (& later) - MWFRS wind pressure zones

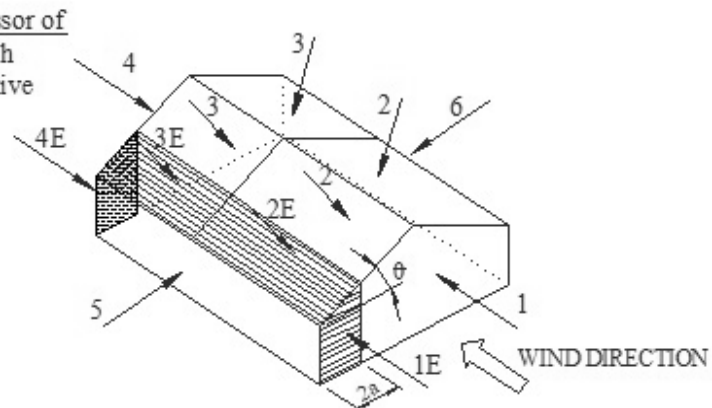
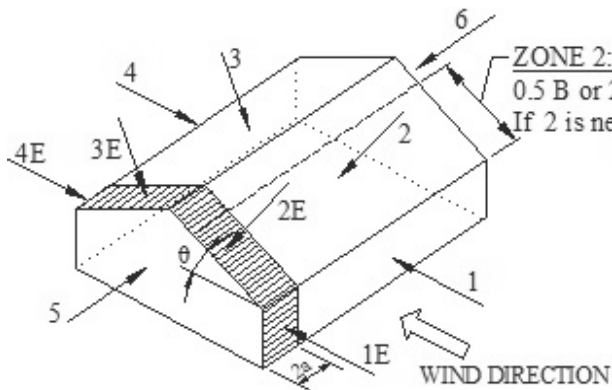

ZONE 2: lessor of
 $0.5 B$ or $2.5 h$
 If 2 is negative

NOTE: Torsional loads are 25% of zones 1 - 4. See code for loading diagram.
 Exception: One story buildings $h < 30'$ and 1 to 2 story buildings framed with light-frame construction or with flexible diaphragms need not be designed for the torsional load case.

ASCE 7-02 and ASCE 7-05 - MWFRS wind pressure zones

Pacific Northwest Structural Group

6193 NE Malbon Ct.
Kingston, WA 98346
(360) 903.2803

JOB TITLE Smith-Cutright Residence Addition & Remodel

JOB NO. 21-028 SHEET NO. _____
CALCULATED BY DLS DATE _____
CHECKED BY DLS DATE _____

Ultimate Wind Pressures

Wind Loads - Components & Cladding : h ≤ 60'

Kh (case 1) = 0.70 h = 26.6 ft
Base pressure (qh) = **18.4 psf** a = 4.6 ft
Minimum parapet ht = 0.0 ft GCpi = +/-0.18
Roof Angle (θ) = 9.5 deg qi = qh = 18.4 psf
Type of roof = Sawtooth

Roof Area	Surface Pressure (psf)							
	10 sf	20 sf	50 sf	100 sf	200 sf	350 sf	500 sf	1000 sf
Negative Zone 1	-34.7	-32.4	-29.4	-27.1	-24.8	-22.9	-21.8	-21.8
Negative Zone 2	-19.9	-19.9	-19.9	-19.9	-17.1	-16.0	-16.0	-16.0
Span A Negative Zone 3	-45.7	-42.8	-38.9	-36	-33.0	-30.7	-29.1	-29.1
Span B,C&D Neg. Zone 3	-62.3	-56.5	-48.7	-42.8	-36.9	-32.2	-29.1	-29.1
Positive Zone 1	16	16	16	16	16.0	16.0	16.0	16.0
Positive Zone 2	#VALUE!	#VALUE!	#VALUE!	#VALUE!				
Positive Zone 3	-31.4	-30.8	-30.1	-29.5	-24.7	-20.9	-18.4	-18.4
					-25.5	-22.3	-20.3	-20.3
					-29.4	-23.8	-20.3	-20.3

User input	
75 sf	300 sf
-28.0	-23.5
-19.9	-16.0
-37.2	-31.3
-45.2	-33.5
16.0	16.0
-29.7	-22.0
-31.0	-23.2
-39.1	-25.4

Overhang pressures in the table above assume an internal pressure coefficient (Gcpi) of 0.0
Overhang soffit pressure equals adj wall pressure (which includes internal pressure of 3.3 psf)

Parapet

qp = 0.0 psf

Solid Parapet Pressure	Surface Pressure (psf)					
	10 sf	20 sf	50 sf	100 sf	200 sf	500 sf
CASE A: Zone 2 :	0.0	0.0	0.0	0.0	0.0	0.0
Zone 3 :	0.0	0.0	0.0	0.0	0.0	0.0
CASE B : Interior zone :	0.0	0.0	0.0	0.0	0.0	0.0
Corner zone :	0.0	0.0	0.0	0.0	0.0	0.0

User input
40 sf
0.0
0.0
0.0
0.0

Walls

Area	GCp +/- GCpi				Surface Pressure at h			
	10 sf	100 sf	200 sf	500 sf	10 sf	100 sf	200 sf	500 sf
Negative Zone 4	-1.17	-1.01	-0.96	-0.90	-21.6	-18.7	-17.8	-16.6
Negative Zone 5	-1.44	-1.12	-1.03	-0.90	-26.6	-20.7	-18.9	-16.6
Positive Zone 4 & 5	1.08	0.92	0.87	0.81	19.9	17.0	16.1	16.0

User input	
10 sf	200 sf
-21.6	-17.8
-26.6	-18.9
19.9	16.1

Note: GCp reduced by 10% due to roof angle ≤ 10 deg.

Location of C&C Wind Pressure Zones - ASCE 7-10 & earlier



.a.

.a.

.2a.

.2a.

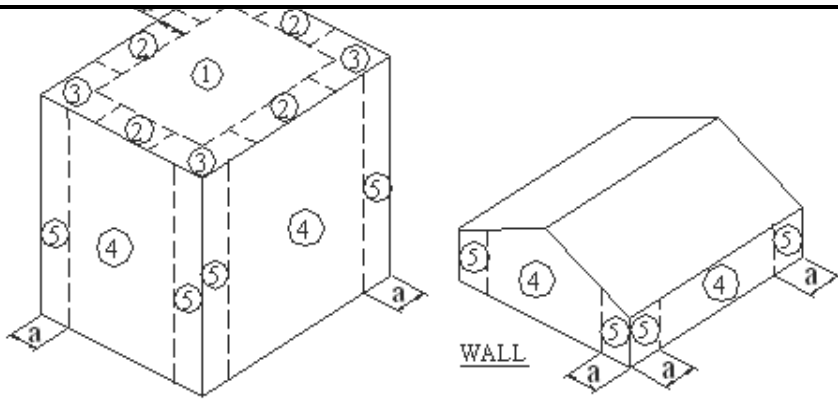

Roofs w/ $\theta \leq 10^\circ$
and all walls
 $h > 60'$

Walls $h \leq 60'$
& alt design $h < 90'$

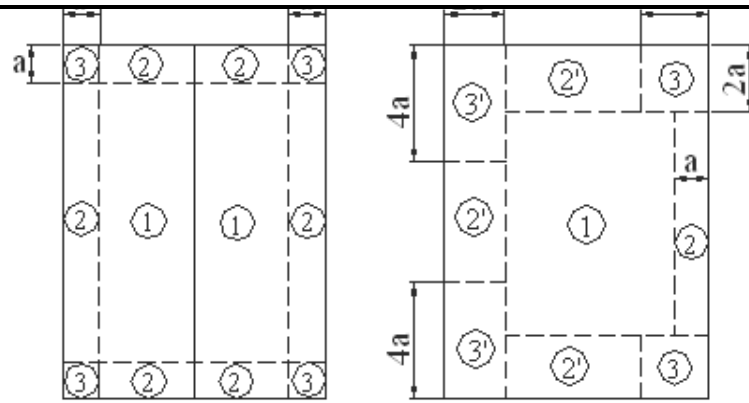

Gable, Sawtooth and
Multispan Gable $\theta \leq 7$ degrees &
Monoslope ≤ 3 degrees
 $h \leq 60'$ & alt design $h < 90'$

Monoslope roofs
 $3^\circ < \theta \leq 10^\circ$
 $h \leq 60'$ & alt design $h < 90'$

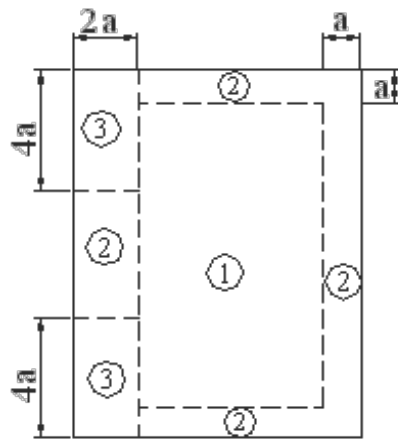

Monoslope roofs
 $10^\circ < \theta \leq 30^\circ$
 $h \leq 60'$ & alt design $h < 90'$

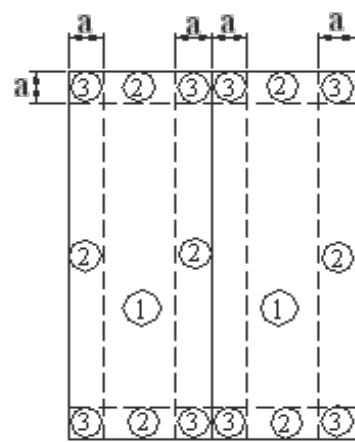

Multispan Gable &
Gable $7^\circ < \theta \leq 45^\circ$

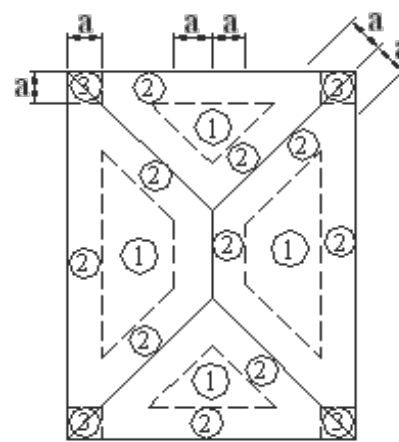

Hip $7^\circ < \theta \leq 27^\circ$

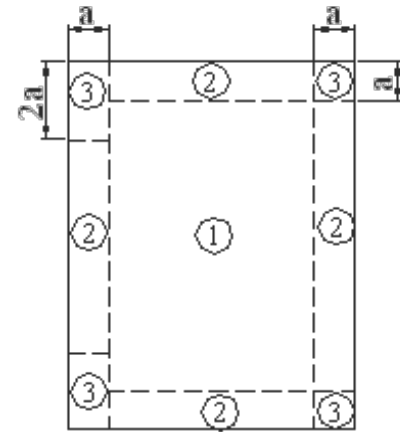
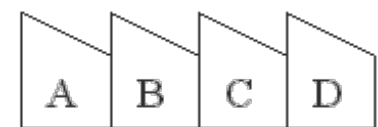

Sawtooth $10^\circ < \theta \leq 45^\circ$
 $h \leq 60'$ & alt design $h < 90'$

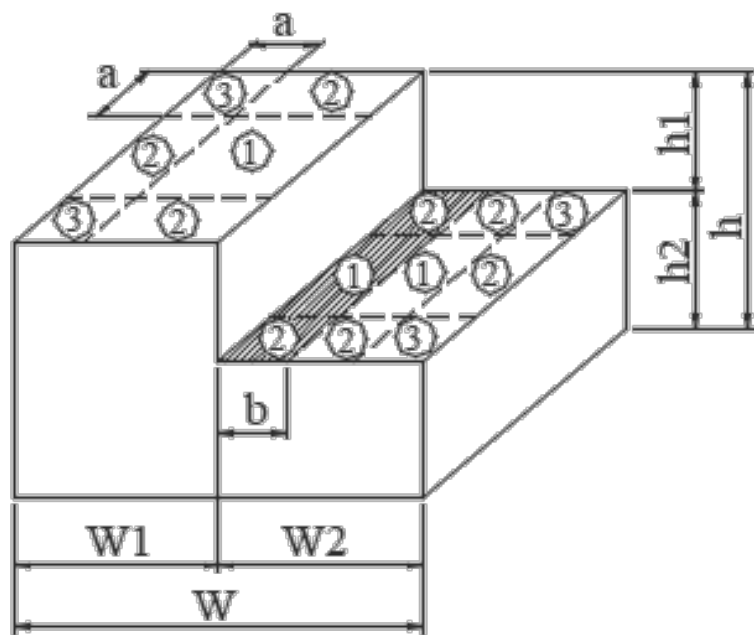

Stepped roofs $\theta \leq 3^\circ$
 $h \leq 60'$ & alt design $h < 90'$

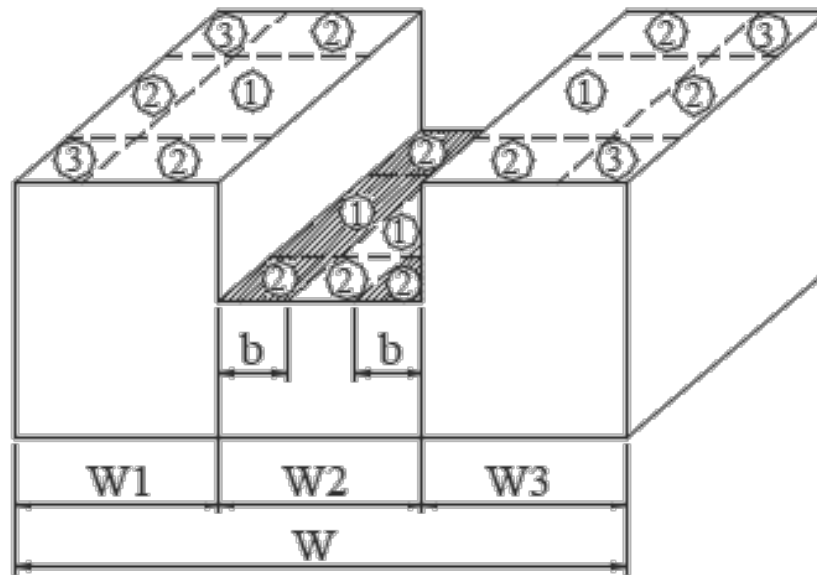

Location of C&C Wind Pressure Zones - ASCE 7-16

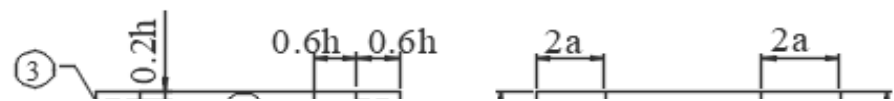
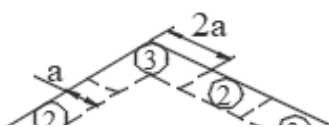

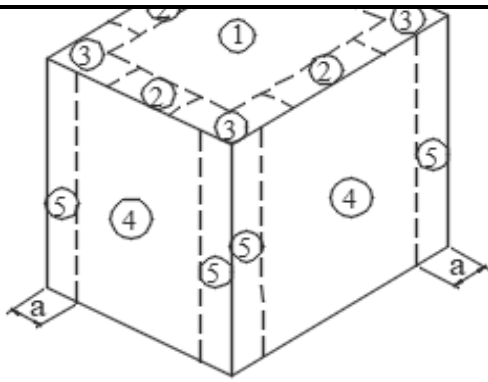

Roofs w/ $\theta \leq 10^\circ$
and all walls
 $h > 60'$

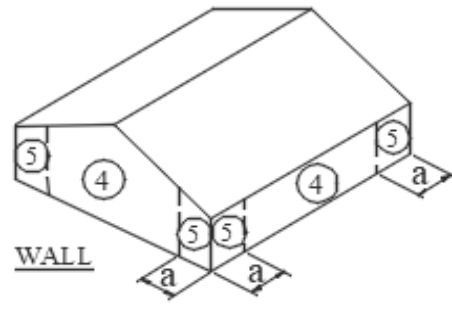

Walls $h \leq 60'$
& alt design $h < 90'$

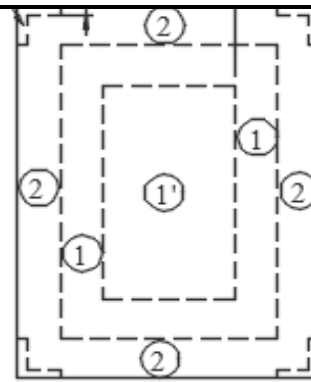

Gable, Sawtooth and
Multispan Gable $\theta \leq 7$ degrees &
Monoslope ≤ 3 degrees
 $h \leq 60'$ & alt design $h < 90'$

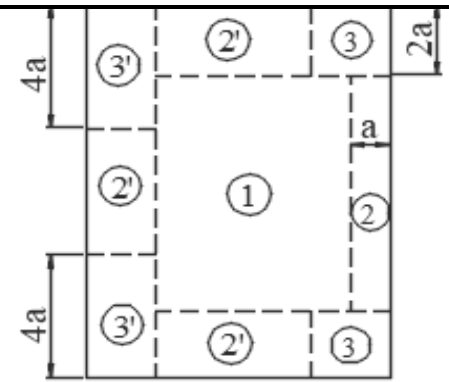

Monoslope roofs
 $3^\circ < \theta \leq 10^\circ$
 $h \leq 60'$ & alt design $h < 90'$

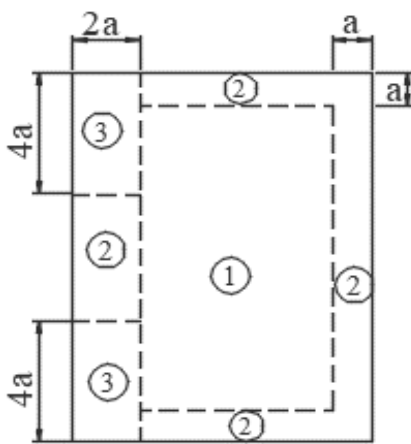

Monoslope roofs
 $10^\circ < \theta \leq 30^\circ$
 $h \leq 60'$ & alt design $h < 90'$

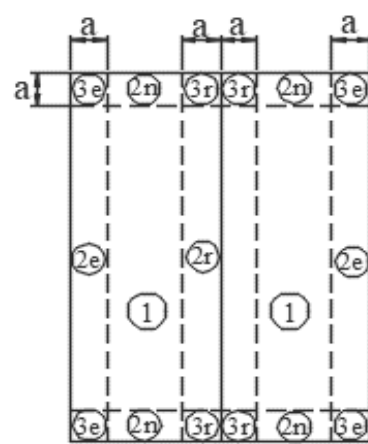

Multispan Gable &
Gable $7^\circ < \theta \leq 45^\circ$

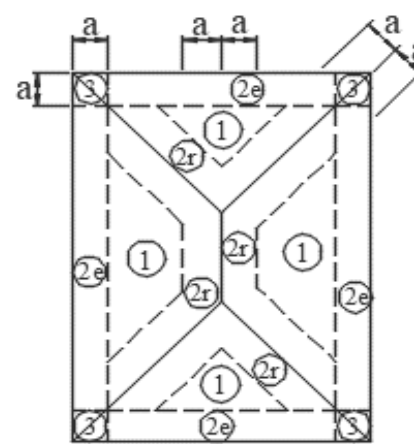

Hip $7^\circ < \theta \leq 27^\circ$

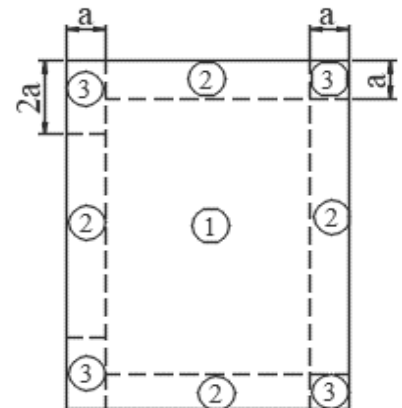

Sawtooth $10^\circ < \theta \leq 45^\circ$
 $h \leq 60'$ & alt design $h < 90'$

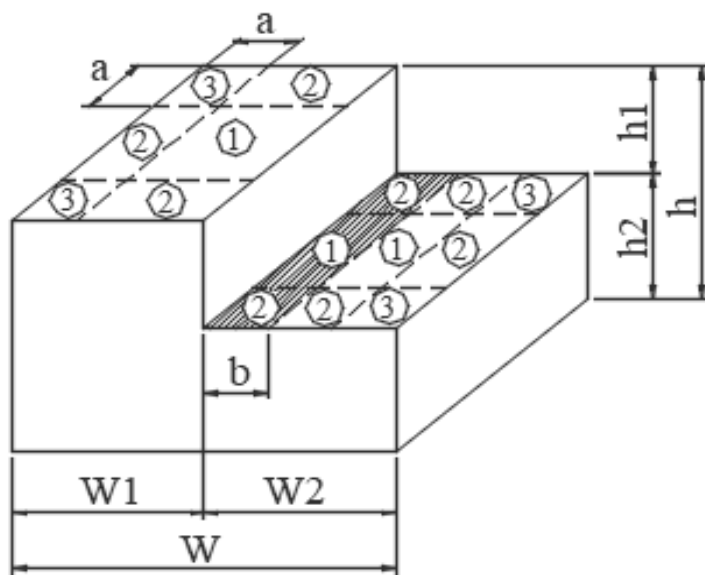

Stepped roofs $\theta \leq 3^\circ$
 $h \leq 60'$ & alt design $h < 90'$

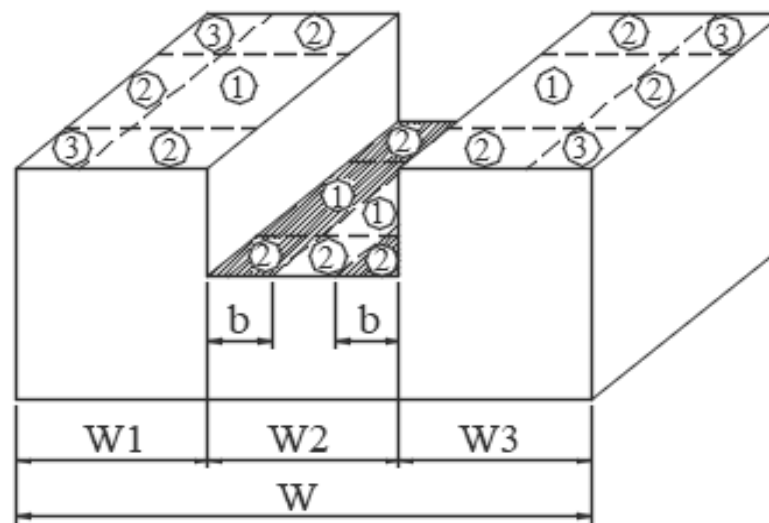

Pacific Northwest Structural Group, Inc.	Project	Smith-Cutright Residence Addition & Remodel	Designer	DLS
	Location	7655 SE 40th Street, Mercer Island, WA 98040	Project No.	21-028
	Client	Laura Smith & David Cutright	Revised	4-Dec-20
	Design Live and Dead Loads, Soil Data			

DESIGN LIVE AND DEAD LOADS

ROOF LOAD :			
Asphalt Shingles		1.5	PSF
Re-Roof		1.5	PSF
Roof Shtg		1.5	PSF
Rafter @ 24" oc		3.3	PSF
Insulation		1.6	PSF
Gypsum Shtg		2.2	PSF
			PSF
			PSF
SUB-TOTAL		11.6	PSF
SLOPE CORRECTION "X:12"	2.00	1.0	
MISCELLANEOUS		3.2	PSF
ROOF DEAD LOAD		15.0	PSF
ROOF SNOW LOAD		25.0	PSF
REDUCED SNOW LOAD		N/A	PSF
ROOF LIVE LOAD		20.0	PSF

EXTERIOR WALL LOAD			
Siding		4.0	PSF
Wall Shtg		1.5	PSF
2x6 @ 16" oc		1.7	PSF
Bottom & Top Plates		0.8	PSF
Insulation		0.5	PSF
Gypsum Shtg		2.2	PSF
Mech., Elec., & Misc.		0.3	PSF
EXTER. WALL DEAD LOAD		11.0	PSF

INTERIOR WALL LOAD			
Gypsum Shtg		4.4	PSF
2X4 @ 16" oc		1.1	PSF
Insulation		0.5	PSF
Bottom & Top Plates		0.8	PSF
Mech., Elec., & Misc.		1.2	PSF
INTERIOR WALL DEAD LOAD		8.0	PSF

FLOOR LOAD			
Floor Covering		1.0	PSF
Floor Shtg		2.3	PSF
Floor Joist		3.3	PSF
Insulation		1.3	PSF
Gypsum Sheathing		5.6	PSF
Mech., Elec., & Misc.		1.5	PSF
			PSF
FLOOR DEAD LOAD		15.0	PSF
FLOOR LIVE LOAD		40.0	PSF

DECK OR BALCONY DEAD LOAD			
2x Decking		4.5	PSF
Deck Joist		3.3	PSF
Mech., Elec., & Misc.		4.2	PSF
			PSF
DECK DEAD LOAD		12.0	PSF
DECK LIVE LOAD		60.0	PSF

			PSF
			PSF
			PSF
			PSF
			PSF
			PSF
			PSF
			PSF
FLOOR DEAD LOAD		-	PSF
FLOOR LIVE LOAD			PSF

SOILS DATA

SOILS REPORT	N/A	DATE OF REPORT	N/A
GEOTECHNICAL ENGINEER	N/A		

BASIC BEARING PRESSURE			
PADS & CONT. FND		1,500	PSF
INCREASE FOR WIDTH		N/A	%
INCREASE FOR DEPTH		N/A	%
MAX. SOIL PRESSURE		1,500	PSF
ISOLATED FOUNDATIONS		N/A	PSF

ACTIVE SOIL PRESSURE			
PASSIVE PRESSURE		N/A	PCF
SOIL FRICTION		N/A	
E.F.P. (Cantilever)		N/A	PCF
E.F.P. (Restrained)		N/A	PCF

Pacific Northwest Structural Group, Inc.	Project	Smith-Cutright Residence Addition & Remodel	Designer	DLS
	Location	7655 SE 40th Street, Mercer Island, WA 98040	Project No.	21-028
	Client	Laura Smith & David Cutright	Revised	4-Dec-20
	ASCE 10-16, 2018 IBC & 2019 OSSC Section 1609 Wind Loads			

BUILDING DATA:

Roof Pitch	2.00	:12
$\theta =$	9.46	
Building Length	45.50	ft
Building Width	49.50	ft
1st Level Plate Height	8.08	ft
2nd Level Plate Height	16.50	ft
3rd Level Plate Height	-	ft
Gable Height	28.71	ft
Roof Height	4.13	ft
Mean Roof Height $h =$	26.64	ft

Horizontal MWFRS Simple Diaphragm Pressures (psf)

Transverse Direction (Normal to Length)	Basic Wind	Allowable Wind
Interior Zone Wall	14.20	8.52
Interior Zone Roof	5.30	3.18
End Zone Wall	21.40	12.84
End Zone Roof	12.70	7.62
Average Wall	17.08	10.25
Average Roof	8.26	4.96
Longitudinal Direction (Parallel to Length)	Basic Wind	Allowable Wind
Interior Zone Wall	12.70	7.62
End Zone Wall	19.20	11.52
Average Wall	15.30	9.60

Allowable Design Uniform Wind Load				
Level	Transverse		Longitudinal	
1st Level Plate	125.9	plf	118.0	plf
2nd Level Plate	105.0	plf	99.0	plf
3rd Level Plate	-	plf	-	plf

Pacific Northwest Structural Group, Inc.	Project	Smith-Cutright Residence Addition & Remodel		Designer	DLS
	Location	7655 SE 40th Street, Mercer Island, WA 9804		Project No.	21-028
	Client	Laura Smith & David Cutright		Revised	14-Jan-21
	ASCE 7-16, 2018 IBC Section 1613, & 2019 OSSC 1613				
ASCE 7-16, IBC 2018 & 2019 OSSC Section 1613, EARTHQUAKE LOADS					
Soil Site Class	D			ASCE 7-16 11.4.3 (Default=D)	
Response Spectral Acc. (0.2 sec) S_s	1.42			ASCE 7-16 Figure(s) 22-1 through 22-18	
Response Spectral Acc. (1.0 sec) S_1	0.49				
Site Coefficient F_a	1.00			ASCE 7-16 Table 11.4-1	
Site Coefficient F_v	1.85			ASCE 7-16 Table 11.4-2	
Max Considered Earthquake Acc. S_{MS}	1.418	$F_a \cdot S_s$		ASCE 7-16 (11.4-1)	
Max Considered Earthquake Acc. S_{M1}	0.912	$F_v \cdot S_1$		ASCE 7-16 (11.4-2)	
@ 5% Damped Design S_{DS}	0.945	$2/3 \cdot S_{MS}$		ASCE 7-16 (11.4-3)	
S_{D1}	0.608	$2/3 \cdot S_{M1}$		ASCE 7-16 (11.4-4)	
Risk Category				II	ASCE 7-16 Table 1.5-1
Design Category Consideration:					
In each of the two orthogonal directions, the approximate fundamental period of the structure, T_a , determined in accordance with Section 12.8.2.1 is less than $0.8T_s$, where T_s is determined in accordance with Section 11.4.5.				Yes	ASCE 7-16 11.6
In each of two orthogonal directions, the fundamental period of the structure used to calculate the story drift is less than T_s .				Yes	
Diaphragms are rigid as defined in Section 12.3.1 or for diaphragms that are flexible, the distance between vertical elements of the seismic force-resisting system does not exceed 40 ft.				Yes	
Seismic Design Category (SDC)	-			ASCE 7-10 11.6	
Seismic Design Category for 0.1 sec	D			ASCE 7-16 Table 11.6-1	
Seismic Design Category for 1.0 sec	D			ASCE 7-16 Table 11.6-2	
$S_1 < .75g$	-			ASCE 7-16 11.6	
Seismic Design Category (SDC)	D			ASCE 7-16 11.6	
Seismic Force-Resisting System	A. BEARING WALL SYSTEMS				
	15. Light-frame (wood) walls sheathed with wood structural panels rated for shear resistance or steel sheets				
Footnotes	-	-			
	-	-			
	-	-			
ASCE 7 Section Where Detailing Requirements Are Specified	14.1 and 14.5				
Building ht. h_n	26.64	ft	Limited Building Height (ft) = 65		
C_t	0.020	x	0.75	ASCE 7-16 Table 12.8-2	
C_u	1.400	for SD1 of 0.608g			ASCE 7-16 Table 12.8-1
Approximate Fundamental Period, T_a	0.235	sec	$C_t \cdot (h_n)^x$	ASCE 7-16 (12.8-7)	
T_s	0.643	sec	S_{D1}/S_{DS}	ASCE 7-16 11.4.6	
T_L	6.00	sec		ASCE 7-16 11.4.6	
Period for Computing Drift	0.328	sec	$C_u \cdot T_a$		
Fundamental Period, T	0.235	sec			
$0.8T_s$	0.515	sec	$0.8(S_{D1}/S_{DS})$	ASCE 7-16 11.6	
Response Modification Coef. R	6.50			ASCE 7-16 Table 12.2-1	

Pacific Northwest Structural Group, Inc.		Project	Smith-Cutright Residence Addition & Remodel	Designer	DLS
		Location	7655 SE 40th Street, Mercer Island, WA 9804	Project No.	21-028
		Client	Laura Smith & David Cutright	Revised	14-Jan-21
		ASCE 7-16, 2018 IBC Section 1613, & 2019 OSSC 1613			
Over Strength Factor Ω_o	3.00		ASCE 7-16 Table 12.2-1		
Deflection Amplification Factor, C_{db}	4.00		ASCE 7-16 Table 12.2-1		
Importance factor I_E	1.00		ASCE 7-16 Table 1.5-2		
C_s	0.145	$S_{DS}/R/I_E$	ASCE 7-16 (12.8-2)		
T<=TL therefore C_s need not to exceed	0.399	$S_{D1}/(T(R/I_E))$	ASCE 7-16 (12.8-3)		
T<TL therefore (12.8-4) N/A	N/A	$S_{D1} \cdot T_L / T^2 (R/I_E)$	ASCE 7-16 (12.8-4)		
C_s	0.042	$0.044 S_{DS} \cdot I_E \geq 0.01$	ASCE 7-16 (12.8-5)		
S1 < 0.6g (12.8-6) N/A	N/A	$0.5 S_1 / (R/I_E)$	ASCE 7-16 (12.8-6)		
Use C_s	0.145				
Design Base Shear V	0.145 W	Control	ASCE 7-16 (12.8-1)		
Design Service Level Base Shear V	0.102 W	Control			

Seismic Load					
Level	W_x (lbs)	h_x (ft)	$W_x \cdot h_x$	C_{vx}	F_x (lbs)
1st Level Plate	42,379	8.8	374,207	0.395	3,092
2nd Level Plate	34,703	16.5	572,600	0.605	4,732
3rd Level Plate	-	-	-	-	-
	77,082	$\Sigma W_x \cdot h_x$	946,806		

Design Service Level Base Shear V	7,824 lbs		
		Transverse	Longitudinal
Diaphragm Width	49.50 ft	45.50 ft	
1st Level Plate	62.5 plf	68.0 plf	
2nd Level Plate	95.6 plf	104.0 plf	
3rd Level Plate	- plf	- plf	

**Pacific Northwest
Structural Group, Inc.**

Project	Smith-Cutright Residence Addition & Remodel	Designer	DLS
Location	7655 SE 40th Street, Mercer Island, WA 98040	Project No.	21-028
Client	Laura Smith & David Cutright	Revised	4-Dec-20
ASCE 7-16 Snow Loads , 2018 IBC 1608, 2019 OSSC 1608			

ASCE 7-10 7.3 FLAT ROOF SNOW LOAD

Ground Snow Load, p_g	30.0	PSF	ASCE 7-16 7.2, 2019 OSSC 1608.2.1
Exposure Category	B		ASCE 7-16 26.7.2, 2019 OSSC 1609.4.2
Exposure of Roof	Partially Exposed		ASCE 7-16 Table 7-3.1
Thermal Condition	All structures except as indicated below		
Risk Category	II		ASCE 7-16 Table 1.5-1
Snow load importance factor, I_s	1.0		ASCE 7-16 Table 1.5-2
Snow exposure factor, C_e	1.00		ASCE 7-16 Table 7-1.3 Exposure Factor
Thermal factor, C_t	1.00		ASCE 7-16 Table 7.3-2 Thermal Factor
Flat-roof snow load, p_f	21.0	PSF	ASCE 7-16 (7.3-1) $0.7C_eC_tI_s p_g$
Min. Design Flat Roof Snow Load, p_m	25.0	PSF	ASCE 7-16 7.3.4 $p_g \leq 20$ PSF $I_s p_g$, $p_g > 20$ PSF $20I_s$
Rain-on-Roof Surcharge Load	5.0	PSF	ASCE 7-16 7.10, 2019 OSSC 1608.2.5
Design Flat Roof Snow Load, p_f	25.0	PSF	

ASCE 7-10 7.4 SLOPE ROOF SNOW LOAD

Roof Pitch	2	:12	
Roof Slope, θ	9.46	°	
Roof Surface	All Other Surfaces		
Warm Roof Slope Factor, C_s	1.00		ASCE 7-16 Section 7.4.1, 7.4.2, 7.4.3 Figure(s)
Slope Roof Design Snow Load, p_s	25.0	PSF	ASCE-7-16 (7-.4-1) $C_s p_f$

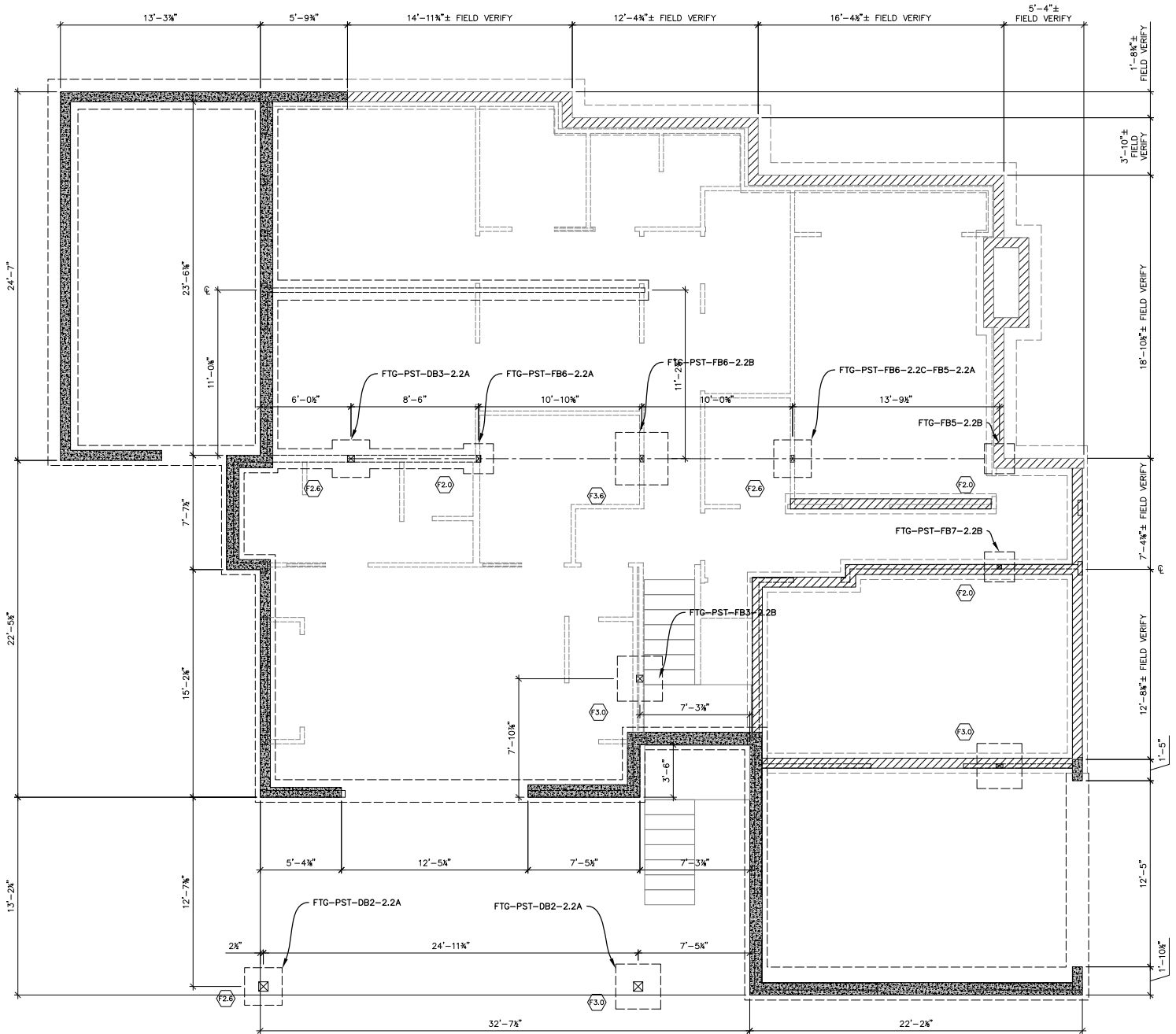

A
S2.1

FOUNDATION/FIRST FLOOR FRAMING PLAN

SCALE: 1/4"=1'-0"

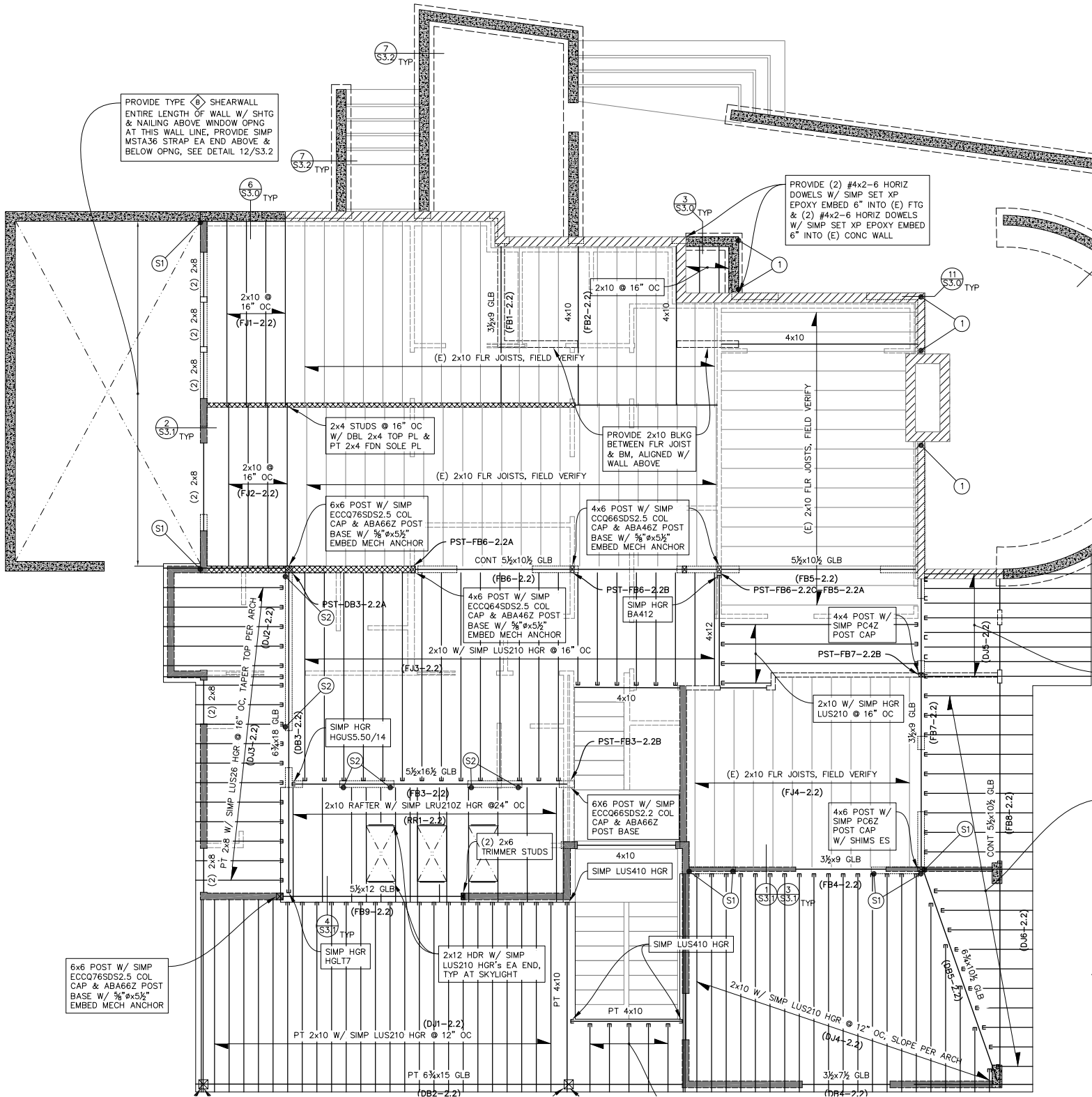

PROVIDE TYPE S SHEARWALL ENTIRE LENGTH OF WALL W/ SHTG & NAILING ABOVE WINDOW OPNG AT THIS WALL LINE. PROVIDE SIMP MSTA36 STRAP EA END ABOVE & BELOW OPNG, SEE DETAIL 12/S3.2

PROVIDE (2) #4x2-6 HORIZ DOWELS W/ SIMP SET XP EPOXY EMBED 6" INTO (E) FTG & (2) #4x2-6 HORIZ DOWELS W/ SIMP SET XP EPOXY EMBED 6" INTO (E) CONC WALL

6x6 POST W/ SIMP ECCO76SDS2.5 COL CAP & ABA66Z POST BASE W/ 3/8"x5 1/2" EMBED MECH ANCHOR

6x6 POST W/ SIMP ECCO76SDS2.5 COL CAP & ABA66Z POST BASE W/ 3/8"x5 1/2" EMBED MECH ANCHOR

4x6 POST W/ SIMP CCQ66SDS2.5 COL CAP & ABA46Z POST BASE W/ 3/8"x5 1/2" EMBED MECH ANCHOR

4x6 POST W/ SIMP ECCO64SDS2.5 COL CAP & ABA46Z POST BASE W/ 3/8"x5 1/2" EMBED MECH ANCHOR

6x6 POST W/ SIMP ECCO66SDS2.2 COL CAP & ABA66Z POST BASE

4x6 POST W/ SIMP PC6Z POST CAP W/ SHIMS ES

SIMP HGR HGLT7

2x12 HDR W/ SIMP LUS210 HGR'S EA END, TYP AT SKYLIGHT

SIMP LUS410 HGR

SIMP LUS410 HGR

PT 2x10 W/ SIMP LUS210 HGR @ 12" OC

2x10 W/ SIMP LUS210 HGR @ 12" OC, SLOPE PER ARCH

PT 6 3/4"x15 GLB

3 1/2"x7 1/2" GLB

(D)3-2.2
2x10 RAFTER W/ SIMP LRU210Z HGR @ 24" OC

(D)3-2.2
SIMP HGR HGUS5.50/14

(D)3-2.2
5 1/2"x12 GLB

(D)3-2.2
PT 2x8 W/ SIMP LUS26 HGR @ 16" OC, TAPER TOP PIER ARCH

(F)1-2.2
2x10 @ 16" OC

(F)2-2.2
2x10 @ 16" OC

(F)3-2.2
2x10 W/ SIMP LUS210 HGR @ 16" OC

(F)3-2.2
2x10 RAFTER W/ SIMP LRU210Z HGR @ 24" OC

(F)3-2.2
5 1/2"x12 GLB

(D)1-2.2
PT 2x10 W/ SIMP LUS210 HGR @ 12" OC

(E) 2x10 FLR JOISTS, FIELD VERIFY

(E) 2x10 FLR JOISTS, FIELD VERIFY

CONT 5 1/2"x10 1/2" GLB

4x10

4x10

PT 4x10

PT 6 3/4"x15 GLB

(F)2-2.2
2x10 @ 16" OC

(E) 2x10 FLR JOISTS, FIELD VERIFY

CONT 5 1/2"x10 1/2" GLB

4x10

4x10

PT 4x10

PT 6 3/4"x15 GLB

(F)4-2.2
2x10 W/ SIMP HGR LUS210 @ 16" OC

(E) 2x10 FLR JOISTS, FIELD VERIFY

CONT 5 1/2"x10 1/2" GLB

4x10

4x10

PT 4x10

PT 6 3/4"x15 GLB

(F)5-2.2
5 1/2"x10 1/2" GLB

(E) 2x10 FLR JOISTS, FIELD VERIFY

CONT 5 1/2"x10 1/2" GLB

4x10

4x10

PT 4x10

PT 6 3/4"x15 GLB

(F)7-2.2
2x10 W/ SIMP HGR LUS210 @ 16" OC

(E) 2x10 FLR JOISTS, FIELD VERIFY

CONT 5 1/2"x10 1/2" GLB

4x10

4x10

PT 4x10

PT 6 3/4"x15 GLB

(F)8-2.2
CONT 5 1/2"x10 1/2" GLB

(E) 2x10 FLR JOISTS, FIELD VERIFY

CONT 5 1/2"x10 1/2" GLB

4x10

4x10

PT 4x10

PT 6 3/4"x15 GLB

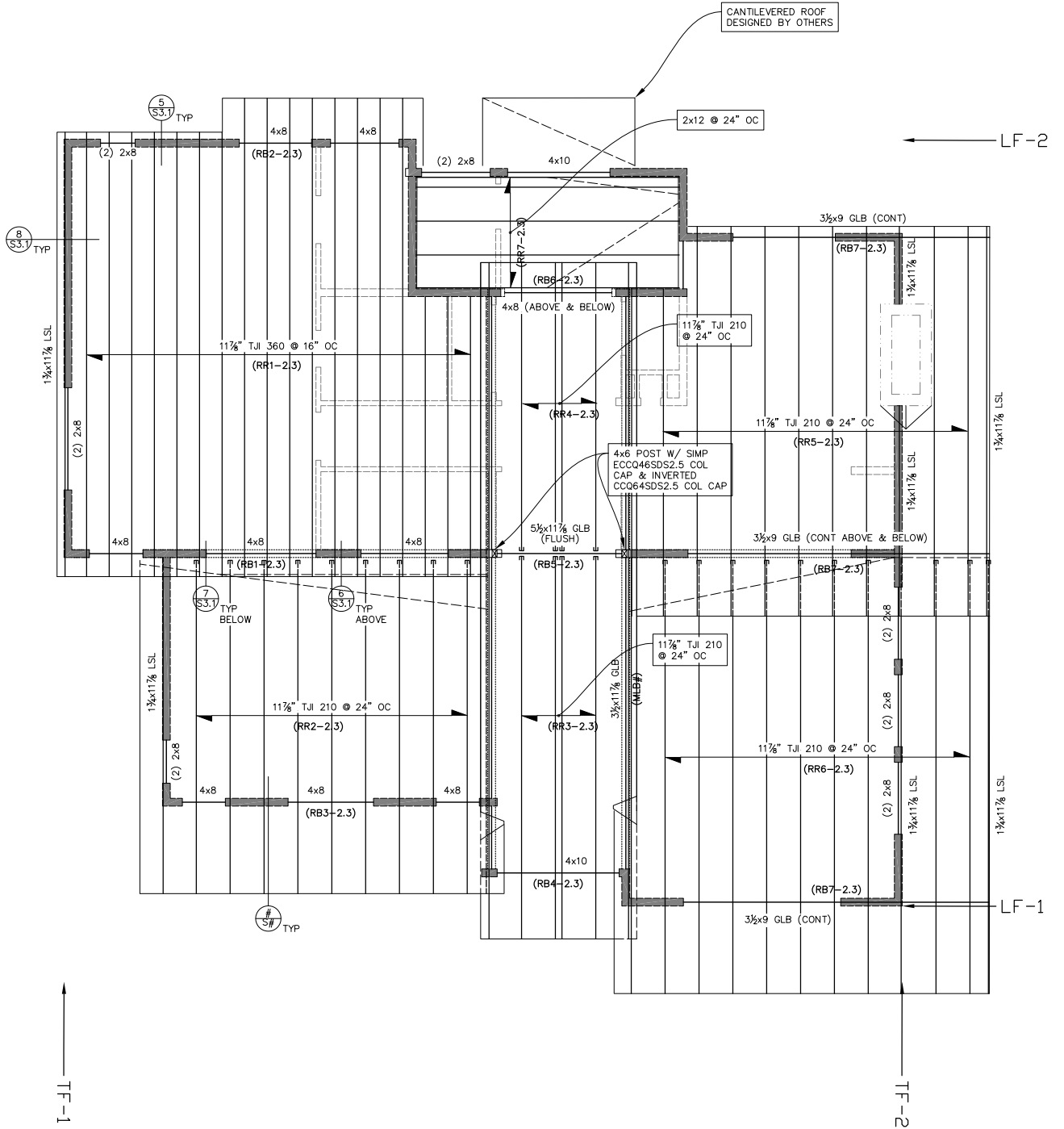

DATE:	10/18/2021	COMPANY:	Pacific Northwest Structural Group, Inc
VITRUVIUS BUILD:	Base	DESIGNED BY:	David Starkel
CUSTOMER:	--	REVIEWED BY:	David Starkel
PROJ. ADDRESS:	--	PROJECT NAME:	21-028 Framing
LEVEL:	S2.2	LOADING:	ASD
MEMBER NAME:	DB1-2.2	CODE:	2018 International Building Code
MEMBER TYPE:	FLOOR BEAM	NDS:	2018 NDS
MATERIAL:	Solid Sawn		
Douglas Fir-Larch	No. 2	(1) 1.5 X 5.5	DRY

DB1-2.2 DIAGRAM



BEAM PROPERTIES

Start (ft): 0 End (ft): 22.083 Member Slope: 0/12 Actual Length (ft): 22.08

Area	Ix	Iy	BSW	Lams	G	Kcr
(in ²)	(in ⁴)	(in ⁴)	(lbf/ft)			Creep Factor
8.25	20.8	1.55	1.88	1	0.5	1

STRENGTH PROPERTIES

	Fb (psi)	Ft (psi)	Fv (psi)	Fc (psi)	Fc⊥ (psi)	E (psi) x10 ³	Emin (psi) x10 ³
Base Values	900	575	180	1350	625	1600	580
Adjusted Values	1170	748	180	1485	625	1600	580
C _M	1	1	1	1	1	1	1
C _T	1	1	1	1	1	1	1
C _i	1	1	1	1	1	1	1
C _F	1.3	1.3	1	1.1	1	1	1

Bending Adjustment Factors C_{fu} = 1 C_r = 1

BEAM DATA

Span	Length (ft)	Unbraced Length (ft)		Beam End				
		Top	Bottom	Elev. Diff (ft)	CL(Top)	CL(Bottom)	CL(Left)	CL(Right)
1	22.08333	0	22.08333	0	1.00	0.59	1.00	1.00

PASS-FAIL

	PASS/FAIL	MAGNITUDE	STRENGTH	LOCATION (ft)	LOAD COMBO	DURATION FACTOR CD
Shear Stress Y (psi)	PASS (97.7%)	3.8	162.0	0	D	0.9
Bending Stress Y (psi)	PASS (82.7%)	182.0	1053.0	11.04	D	0.9
Deflection (in)	PASS (72.6%)	0.303 (=L/876)	1.104 (=L/240)	11.04	D+L	
Bearing Stress (psi)	PASS (99.4%)	4.0	625.0	0	D	0.9

REACTIONS

Units for V: lbf Units for M: lbf-ft

Y axis	DEAD	LIVE	LIVE ROOF	SNOW	WIND +	WIND -	SEISMIC +	SEISMIC -	ICE	RAIN	EARTH
A	21	0	0	0	0	0	0	0	0	0	0
B	21	0	0	0	0	0	0	0	0	0	0

Reaction Location

A

B

LOAD LIST

Type	Left Magnitude	Right Magnitude	Load Start (ft)	Load End (ft)	Load Type	Direction
Self Weight (lbf/ft)	1.88	1.88	0	22.08333	Dead	Y

DATE:	10/18/2021	COMPANY:	Pacific Northwest Structural Group, Inc
VITRUVIUS BUILD:	Base	DESIGNED BY:	David Starkel
CUSTOMER:		REVIEWED BY:	David Starkel
PROJ. ADDRESS:	--	PROJECT NAME:	21-028 Framing
	--		
LEVEL:	S2.2	LOADING:	ASD
MEMBER NAME:	DB2-2.2	CODE:	2018 International Building Code
MEMBER TYPE:	FLOOR BEAM	NDS:	2018 NDS
MATERIAL:	Glulams		
Stress Class Rated 24F-1.8E	24F-V4 DF/DF	(1) 6.75 X 15	DRY

DB2-2.2 DIAGRAM



BEAM PROPERTIES

Start (ft): 0 End (ft): 33 Member Slope: 0/12 Actual Length (ft): 33

Area	Ix	Iy	BSW	Lams	G	Kcr
(in ²)	(in ⁴)	(in ⁴)	(lbf/ft)			Creep Factor
101.25	1898.44	384.43	23.09	1	0.5	1

STRENGTH PROPERTIES

	Fbx+	Fbx-	Fby	Ft	Fvx	Fvy	Fc	Fc _⊥	Ex	Exmin	Ey	Eymin
	(psi)	(psi)	(psi)	(psi)	(psi)	(psi)	(psi)	(psi)	(psi)	(psi)	(psi)	(psi)
Base Values	2400	1850	1450	1100	265	230	1650	650	1800000	950000	1600000	850000
Adjusted Values	2400	1850	1450	1100	265	230	1650	650	1800000	950000	1600000	850000
C _M	1	1	1	1	1	1	1	1	1	1	1	1
C _T	1	1	1	1	1	1	1	1	1	1	1	1

Bending Adjustment Factors C_{VR} = 1

BEAM DATA

Span	Length (ft)	Unbraced Length (ft)		Beam End				
		Top	Bottom	Elev. Diff (ft)	CL(Top)	CL(Bottom)	CL(Left)	CL(Right)
1	25	0	25	0	1.00	0.99	1.00	1.00
2	8	0	8	0	1.00	1.00	1.00	1.00

PASS-FAIL

	PASS/FAIL	MAGNITUDE	STRENGTH	LOCATION (ft)	LOAD COMBO	DURATION FACTOR	CD
Shear Stress Y (psi)	PASS (56.3%)	115.7	265.0	24.75	D+L		1
Bending Stress Y (psi)	PASS (11.1%)	1495.0	1682.2	25.08	D+L		1
Deflection (in)	PASS (30.9%)	0.576 (=L/521)	0.833 (=L/360)	11.22	L		
Bearing Stress (psi)	PASS (25.4%)	536.8	719.6	25	D+L		1

REACTIONS

Units for V: lbf Units for M: lbf-ft

Y axis	DEAD	LIVE	LIVE ROOF	SNOW	WIND +	WIND -	SEISMIC +	SEISMIC -	ICE	RAIN	EARTH
A	1263	4125	0	0	0	0	0	0	0	0	0
B	3046	9636	0	0	0	0	0	0	0	0	0
C	-699	-2540	0	0	0	0	0	0	0	0	0

Reaction Location

A

B

C

LOAD LIST

Type	Left Magnitude	Right Magnitude	Load Start (ft)	Load End (ft)	Load Type	Direction
Self Weight (lbf/ft)	23.09	23.09	0	33	Dead	Y

LINKED LOAD LIST

Type	Left Magnitude	Right Magnitude	Load Start (ft)	Load End (ft)	Load Type	Direction
Uniform (lbf/ft)	37.14373	37.14373	25	33	Dead	Y
Uniform (lbf/ft)	127.3681	127.3681	25	33	Live	Y
Uniform (lbf/ft)	102.0234	102.0234	0	25	Dead	Y
Uniform (lbf/ft)	408.0938	408.0938	0	25	Live	Y

DATE:	10/18/2021	COMPANY:	Pacific Northwest Structural Group, Inc
VITRUVIUS BUILD:	Base	DESIGNED BY:	David Starkel
CUSTOMER:		REVIEWED BY:	David Starkel
PROJ. ADDRESS:	--	PROJECT NAME:	21-028 Framing
	--		
LEVEL:	S2.2	LOADING:	ASD
MEMBER NAME:	DB3-2.2	CODE:	2018 International Building Code
MEMBER TYPE:	FLOOR BEAM	NDS:	2018 NDS
MATERIAL:	Glulams		
Stress Class Rated 24F-1.8E	24F-V4 DF/DF	(1) 6.75 X 18	DRY

DB3-2.2 DIAGRAM



BEAM PROPERTIES

Start (ft): 0 End (ft): 22.333 Member Slope: 0/12 Actual Length (ft): 22.33

Area	Ix	Iy	BSW	Lams	G	Kcr
(in ²)	(in ⁴)	(in ⁴)	(lbf/ft)			Creep Factor
121.5	3280.5	461.32	27.71	1	0.5	1

STRENGTH PROPERTIES

	Fbx+	Fbx-	Fby	Ft	Fvx	Fvy	Fc	Fc⊥	Ex	Exmin	Ey	Eymin
	(psi)	(psi)	(psi)	(psi)	(psi)	(psi)	(psi)	(psi)	(psi)	(psi)	(psi)	(psi)
Base Values	2400	1850	1450	1100	265	230	1650	650	1800000	950000	1600000	850000
Adjusted Values	2400	1850	1450	1100	265	230	1650	650	1800000	950000	1600000	850000
C _M	1	1	1	1	1	1	1	1	1	1	1	1
C _T	1	1	1	1	1	1	1	1	1	1	1	1
Bending Adjustment Factors	C _{VR} = 1											

BEAM DATA

Span	Length (ft)	Unbraced Length (ft)		Beam End				
		Top	Bottom	Elev. Diff (ft)	CL(Top)	CL(Bottom)	CL(Left)	CL(Right)
1	22.3334	0	22.3334	0	1.00	0.98	1.00	1.00

PASS-FAIL

	PASS/FAIL	MAGNITUDE	STRENGTH	LOCATION (ft)	LOAD COMBO	DURATION FACTOR CD
Shear Stress Y (psi)	PASS (61.4%)	102.3	265.0	22.33	D+L	1.15
Bending Stress Y (psi)	PASS (15.1%)	2176.0	2562.5	14.52	D+0.75L+0.75S	1
Deflection (in)	PASS (30.4%)	0.777 (=L/345)	1.117 (=L/240)	11.61	D+L	
Compressive Stress (psi)	PASS (100.0%)	0.0	1855.9	7.37	D+Lr	1.25
Tensile Stress (psi)	PASS (100.0%)	0.0	1375.0	7.37	D+Lr	1.25
Bearing Stress (psi)	PASS (57.1%)	279.0	650.0	22.33	D+0.75L+0.75S	1.15
Bending-Compression (Unit)	PASS (15.1%)	0.85	1.00	14.52	D+0.75L+0.75S	1.15
Bending-Tension (Unit)	PASS (30.9%)	0.69	1.00	14.52	D+0.75L+0.75Lr	1.25

REACTIONS		Units for V: lbf		Units for M: lbf-ft							
Z axis	DEAD	LIVE	LIVE ROOF	SNOW	WIND +	WIND -	SEISMIC +	SEISMIC -	ICE	RAIN	EARTH
A	0	0	3 / -2	1	0	0	0	0	0	0	0
B	0	0	0	0	0	0	0	0	0	0	0
Y axis											
A	3769	3259	1449	1811	0	0	0	0	0	0	0
B	4514	3773	2211	2763	0	0	0	0	0	0	0

Reaction Location

A

B

CONNECTORS		(All connectors are Simpson Strong-Tie connectors)*			Header	Joist Nails (in)	Nailer
Support B	Model	Type	Adequacy (%)	Fastening (in)		Thickness (in)	
Primary	HGLT7	Hanger	12.16	(18) N54A	(6) N54A	N/A	

Hanger at support B has seat sloped 0 degrees, skewed 0 degrees.

WSR = web stiffeners required

*Capacity values are adjusted based on specific gravity when members use grades other than those specified in Simpson Strong-Tie's capacity tables.



LOAD LIST							
Type	Left Magnitude	Right Magnitude	Load Start (ft)	Load End (ft)	Load Type	Direction	
Uniform (lbf/ft)	50	50	0	14.6667	Snow	Y	
Uniform (lbf/ft)	123.5	123.5	0	14.6667	Dead	Y	
Uniform (lbf/ft)	40	40	0	14.6667	Roof Live	Y	
Self Weight (lbf/ft)	27.71	27.71	0	22.3334	Dead	Y	

LINKED LOAD LIST							
Type	Left Magnitude	Right Magnitude	Load Start (ft)	Load End (ft)	Load Type	Direction	
Point (lbf)	4677.405	-	14.6667	-	Dead	Y	
Point (lbf)	2786.667	-	14.6667	-	Live	Y	
Point (lbf)	3841.006	-	14.6667	-	Snow	Y	
Point (lbf)	-1.273669	-	14.6667	-	Snow	Z	
Point (lbf)	1.757772	-	14.6667	-	Roof Live	Z	
Point (lbf)	3072.984	-	14.6667	-	Roof Live	Y	
Point (lbf)	-2.918893	-	14.6667	-	Roof Live	Z	
Uniform (lbf/ft)	66.17825	66.17825	0	7.3334	Dead	Y	
Uniform (lbf/ft)	239.0621	239.0621	0	7.3334	Live	Y	
Uniform (lbf/ft)	45.99631	45.99631	7.3334	22.3334	Dead	Y	
Uniform (lbf/ft)	166.1569	166.1569	7.3334	22.3334	Live	Y	

DATE:	10/18/2021	COMPANY:	Pacific Northwest Structural Group, Inc
VITRUVIUS BUILD:	Base	DESIGNED BY:	David Starkel
CUSTOMER:		REVIEWED BY:	David Starkel
PROJ. ADDRESS:	--	PROJECT NAME:	21-028 Framing
	--		
LEVEL:	S2.2	LOADING:	ASD
MEMBER NAME:	DB4-2.2	CODE:	2018 International Building Code
MEMBER TYPE:	FLOOR BEAM	NDS:	2018 NDS
MATERIAL:	Glulams		
Stress Class Rated 24F-1.8E	24F-V4 DF/DF	(1) 3.5 X 7.5	DRY

DB4-2.2 DIAGRAM



BEAM PROPERTIES

Start (ft): 0 End (ft): 6.333 Member Slope: 0/12 Actual Length (ft): 6.33

Area	Ix	Iy	BSW	Lams	G	Kcr
(in ²)	(in ⁴)	(in ⁴)	(lbf/ft)			Creep Factor
26.25	123.05	26.8	5.99	1	0.5	1

STRENGTH PROPERTIES

	Fbx+	Fbx-	Fby	Ft	Fvx	Fvy	Fc	Fc _⊥	Ex	Exmin	Ey	Eymin
	(psi)	(psi)	(psi)	(psi)	(psi)	(psi)	(psi)	(psi)	(psi)	(psi)	(psi)	(psi)
Base Values	2400	1850	1450	1100	265	230	1650	650	1800000	950000	1600000	850000
Adjusted Values	2400	1850	1528	1100	265	230	1650	650	1800000	950000	1600000	850000
C _M	1	1	1	1	1	1	1	1	1	1	1	1
C _T	1	1	1	1	1	1	1	1	1	1	1	1
Bending Adjustment Factors	C _{VR} = 1											

BEAM DATA

Span	Length (ft)	Unbraced Length (ft)		Beam End				
		Top	Bottom	Elev. Diff (ft)	CL(Top)	CL(Bottom)	CL(Left)	CL(Right)
1	6.3334	0	6.3334	0	1.00	0.99	1.00	1.00

PASS-FAIL

	PASS/FAIL	MAGNITUDE	STRENGTH	LOCATION (ft)	LOAD COMBO	DURATION FACTOR	CD
Shear Stress Y (psi)	PASS (62.5%)	99.5	265.0	0	D+L	1	
Bending Stress Y (psi)	PASS (58.0%)	1008.1	2400.0	3.17	D+L	1	
Deflection (in)	PASS (66.3%)	0.071 (=L/1069)	0.211 (=L/360)	3.17	L		
Bearing Stress (psi)	PASS (78.1%)	142.1	650.0	0	D+L	1	

REACTIONS

Units for V: lbf Units for M: lbf-ft

Y axis	DEAD	LIVE	LIVE ROOF	SNOW	WIND +	WIND -	SEISMIC +	SEISMIC -	ICE	RAIN	EARTH
A	363	1378	0	0	0	0	0	0	0	0	0
B	363	1378	0	0	0	0	0	0	0	0	0

Reaction Location

A

B

LOAD LIST

Type	Left Magnitude	Right Magnitude	Load Start (ft)	Load End (ft)	Load Type	Direction
Self Weight (lbf/ft)	5.99	5.99	0	6.3334	Dead	Y

LINKED LOAD LIST

Type	Left Magnitude	Right Magnitude	Load Start (ft)	Load End (ft)	Load Type	Direction
Uniform (lb/ft)	108.75	108.75	0	6.3334	Dead	Y
Uniform (lb/ft)	435	435	0	6.3334	Live	Y

DATE:	10/18/2021	COMPANY:	Pacific Northwest Structural Group, Inc
VITRUVIUS BUILD:	Base	DESIGNED BY:	David Starkel
CUSTOMER:		REVIEWED BY:	David Starkel
PROJ. ADDRESS:	-- --	PROJECT NAME:	21-028 Framing
LEVEL:	S2.2	LOADING:	ASD
MEMBER NAME:	DB5-2.2	CODE:	2018 International Building Code
MEMBER TYPE:	FLOOR BEAM	NDS:	2018 NDS
MATERIAL:	Glulams		
Stress Class Rated 24F-1.8E	24F-V4 DF/DF	(1) 6.75 X 10.5	DRY

DB5-2.2 DIAGRAM



BEAM PROPERTIES

Start (ft): 0 End (ft): 15.5 Member Slope: 0/12 Actual Length (ft): 15.5

Area	Ix	Iy	BSW	Lams	G	Kcr
(in ²)	(in ⁴)	(in ⁴)	(lbf/ft)			Creep Factor
70.88	651.16	269.1	16.16	1	0.5	1

STRENGTH PROPERTIES

	Fbx+	Fbx-	Fby	Ft	Fvx	Fvy	Fc	Fc⊥	Ex	Exmin	Ey	Eymin
	(psi)	(psi)	(psi)	(psi)	(psi)	(psi)	(psi)	(psi)	(psi)	(psi)	(psi)	(psi)
Base Values	2400	1850	1450	1100	265	230	1650	650	1800000	950000	1600000	850000
Adjusted Values	2400	1850	1472	1100	265	230	1650	650	1800000	950000	1600000	850000
C _M	1	1	1	1	1	1	1	1	1	1	1	1
C _T	1	1	1	1	1	1	1	1	1	1	1	1
Bending Adjustment Factors	C _{VR} = 1											

BEAM DATA

Span	Length (ft)	Unbraced Length (ft)		Beam End				
		Top	Bottom	Elev. Diff (ft)	CL(Top)	CL(Bottom)	CL(Left)	CL(Right)
1	15.5	0	15.5	0	1.00	0.99	1.00	1.00

PASS-FAIL

	PASS/FAIL	MAGNITUDE	STRENGTH	LOCATION (ft)	LOAD COMBO	DURATION FACTOR CD
Shear Stress Y (psi)	PASS (68.9%)	82.5	265.0	0	D+L	1
Bending Stress Y (psi)	PASS (50.6%)	1184.6	2400.0	6.82	D+L	1
Deflection (in)	PASS (17.3%)	0.427 (=L/435)	0.517 (=L/360)	7.44	L	
Bearing Stress (psi)	PASS (74.6%)	165.1	650.0	0	D+L	1

REACTIONS

Y axis	DEAD	LIVE	LIVE ROOF	SNOW	WIND +	WIND -	SEISMIC +	SEISMIC -	ICE	RAIN	EARTH
A	125	3775	0	0	0	0	0	0	0	0	0
B	125	2197	0	0	0	0	0	0	0	0	0

Reaction Location

A

B

UNBALANCED LIVE LOAD - WORST CASE

Load Combination: L, Maximum Stress Ratios from: Deflection

-Live Load Applied

LOAD LIST

Type	Left Magnitude	Right Magnitude	Load Start (ft)	Load End (ft)	Load Type	Direction
Trapezoidal (lbf/ft)	552.6	40	0	15.5	Live	Y
Trapezoidal (lbf/ft)	138	40	0	15.5	Live	Y
Self Weight (lbf/ft)	16.16	16.16	0	15.5	Dead	Y

DATE:	10/18/2021	COMPANY:	Pacific Northwest Structural Group, Inc		
VITRUVIUS BUILD:	Base	DESIGNED BY:	David Starkel		
CUSTOMER:		REVIEWED BY:	David Starkel		
PROJ. ADDRESS:	--	PROJECT NAME:	21-028 Framing		
	--				
LEVEL:	S2.2	LOADING:	ASD		
MEMBER NAME:	DJ1-2.2	CODE:	2018 International Building Code		
MEMBER TYPE:	FLOOR JOIST	NDS:	2018 NDS		
MATERIAL:	Solid Sawn				
Hem-Fir	No. 2	(1) 1.5 X 9.25	12(in) O.C.	DRY	INCISED

DJ1-2.2 DIAGRAM



BEAM PROPERTIES

Start (ft): 0 End (ft): 13.083 Member Slope: 0/12 Actual Length (ft): 13.08 O.C. Spacing(in): 12

Area	I _x	I _y	BSW	Lams	G	K _{cr}
(in ²)	(in ⁴)	(in ⁴)	(lbf/ft)			Creep Factor
13.88	98.93	2.6	2.74	1	0.43	1

STRENGTH PROPERTIES

	F _b (psi)	F _t (psi)	F _v (psi)	F _c (psi)	F _{c⊥} (psi)	E (psi) x10 ³	E _{min} (psi) x10 ³
Base Values	850	525	150	1300	405	1300	470
Adjusted Values	860	462	120	1040	405	1235	446
C _M	1	1	1	1	1	1	1
C _T	1	1	1	1	1	1	1
C _i	0.8	0.8	0.8	0.8	1	0.95	0.95
C _F	1.1	1.1	1	1	1	1	1

Bending Adjustment Factors C_{fu} = 1 C_r = 1.15

BEAM DATA

Span	Length (ft)	Unbraced Length (ft)		Beam End				
		Top	Bottom	Elev. Diff (ft)	CL(Top)	CL(Bottom)	CL(Left)	CL(Right)
1	12.58333	0	12.58333	0	1.00	0.58	1.00	1.00
2	0.5	0	0.5	0	1.00	1.00	1.00	1.00

PASS-FAIL

	PASS/FAIL	MAGNITUDE	STRENGTH	LOCATION (ft)	LOAD COMBO	DURATION FACTOR CD
Shear Stress Y (psi)	PASS (57.6%)	50.9	120.0	0	D+L	1
Bending Stress Y (psi)	PASS (3.5%)	830.1	860.2	6.28	D+L	1
Deflection (in)	PASS (34.2%)	0.276 (=L/547)	0.419 (=L/360)	6.28	L	
Bearing Stress (psi)	PASS (77.8%)	89.7	405.0	0	D+L	1

REACTIONS

Units for V: lbf Units for M: lbf-ft

Y axis	DEAD	LIVE	LIVE ROOF	SNOW	WIND +	WIND -	SEISMIC +	SEISMIC -	ICE	RAIN	EARTH
A	94	377	0	0	0	0	0	0	0	0	0
B	102	408	0	0	0	0	0	0	0	0	0
C	0	0	0	0	0	0	0	0	0	0	0

Reaction Location

A

B C

LOAD LIST

Type	Left Magnitude	Right Magnitude	Load Start (ft)	Load End (ft)	Load Type	Direction
Uniform (lb/ft ²)	60	60	0	13.08333	Live	Y
Uniform (lb/ft ²)	15	15	0	13.08333	Dead	Y

DATE:	10/18/2021	COMPANY:	Pacific Northwest Structural Group, Inc		
VITRUVIUS BUILD:	Base	DESIGNED BY:	David Starkel		
CUSTOMER:		REVIEWED BY:	David Starkel		
PROJ. ADDRESS:	-- --	PROJECT NAME:	21-028 Framing		
LEVEL:	S2.2	LOADING:	ASD		
MEMBER NAME:	DJ2-2.2	CODE:	2018 International Building Code		
MEMBER TYPE:	FLOOR JOIST	NDS:	2018 NDS		
MATERIAL:	Solid Sawn				
Hem-Fir	No. 2	(1) 1.5 X 7.25	16(in) O.C.	DRY	INCISED

DJ2-2.2 DIAGRAM



BEAM PROPERTIES

Start (ft): 0 End (ft): 8.5 Member Slope: 0/12 Actual Length (ft): 8.5 O.C. Spacing(in): 16

Area	I _x	I _y	BSW	Lams	G	K _{cr}
(in ²)	(in ⁴)	(in ⁴)	(lbf/ft)			Creep Factor
10.88	47.63	2.04	2.15	1	0.43	1

STRENGTH PROPERTIES

	F _b (psi)	F _t (psi)	F _v (psi)	F _c (psi)	F _{c⊥} (psi)	E (psi) x10 ³	E _{min} (psi) x10 ³
Base Values	850	525	150	1300	405	1300	470
Adjusted Values	938	504	120	1092	405	1235	446
C _M	1	1	1	1	1	1	1
C _T	1	1	1	1	1	1	1
C _i	0.8	0.8	0.8	0.8	1	0.95	0.95
C _F	1.2	1.2	1	1.05	1	1	1

Bending Adjustment Factors C_{fu} = 1 C_r = 1.15

BEAM DATA

Span	Length (ft)	Unbraced Length (ft)		Beam End				
		Top	Bottom	Elev. Diff (ft)	CL(Top)	CL(Bottom)	CL(Left)	CL(Right)
1	8	0	8	0	1.00	0.86	1.00	1.00
2	0.5	0	0.5	0	1.00	1.00	1.00	1.00

PASS-FAIL

	PASS/FAIL	MAGNITUDE	STRENGTH	LOCATION (ft)	LOAD COMBO	DURATION FACTOR CD
Shear Stress Y (psi)	PASS (53.0%)	56.4	120.0	7.99	D+L	1
Bending Stress Y (psi)	PASS (21.1%)	740.4	938.4	3.99	D+L	1
Deflection (in)	PASS (26.0%)	0.025 (=L/485)	0.033 (=L/360)	8.5	L	
Bearing Stress (psi)	PASS (80.4%)	87.9	448.4	8	D+L	1

REACTIONS

Units for V: lbf Units for M: lbf-ft

Y axis	DEAD	LIVE	LIVE ROOF	SNOW	WIND +	WIND -	SEISMIC +	SEISMIC -	ICE	RAIN	EARTH
A	88	319	0	0	0	0	0	0	0	0	0
B	100	361	0	0	0	0	0	0	0	0	0
C	0	0	0	0	0	0	0	0	0	0	0

Reaction Location

A

B

C

LOAD LIST

Type	Left Magnitude	Right Magnitude	Load Start (ft)	Load End (ft)	Load Type	Direction
Uniform (lb/ft ²)	60	60	0	8.5	Live	Y
Uniform (lb/ft ²)	15	15	0	8.5	Dead	Y
Self Weight (lb/ft)	2.15	2.15	0	8.5	Dead	Y

DATE:	10/18/2021	COMPANY:	Pacific Northwest Structural Group, Inc		
VITRUVIUS BUILD:	Base	DESIGNED BY:	David Starkel		
CUSTOMER:		REVIEWED BY:	David Starkel		
PROJ. ADDRESS:	-- --	PROJECT NAME:	21-028 Framing		
LEVEL:	S2.2	LOADING:	ASD		
MEMBER NAME:	DJ3-2.2	CODE:	2018 International Building Code		
MEMBER TYPE:	FLOOR JOIST	NDS:	2018 NDS		
MATERIAL:	Solid Sawn				
Hem-Fir	No. 2	(1) 1.5 X 7.25	16(in) O.C.	DRY	INCISED

DJ3-2.2 DIAGRAM



BEAM PROPERTIES

Start (ft): 0 End (ft): 6.083 Member Slope: 0/12 Actual Length (ft): 6.08 O.C. Spacing(in): 16

Area	I _x	I _y	BSW	Lams	G	K _{cr}
(in ²)	(in ⁴)	(in ⁴)	(lbf/ft)			Creep Factor
10.88	47.63	2.04	2.15	1	0.43	1

STRENGTH PROPERTIES

	F _b (psi)	F _t (psi)	F _v (psi)	F _c (psi)	F _{c⊥} (psi)	E (psi) x10 ³	E _{min} (psi) x10 ³
Base Values	850	525	150	1300	405	1300	470
Adjusted Values	938	504	120	1092	405	1235	446
C _M	1	1	1	1	1	1	1
C _T	1	1	1	1	1	1	1
C _i	0.8	0.8	0.8	0.8	1	0.95	0.95
C _F	1.2	1.2	1	1.05	1	1	1

Bending Adjustment Factors C_{fu} = 1 C_r = 1.15

BEAM DATA

Span	Length (ft)	Unbraced Length (ft)		Beam End				
		Top	Bottom	Elev. Diff (ft)	CL(Top)	CL(Bottom)	CL(Left)	CL(Right)
1	5.58334	0	5.58334	0	1.00	0.94	1.00	1.00
2	0.5	0	0.5	0	1.00	1.00	1.00	1.00

PASS-FAIL

	PASS/FAIL	MAGNITUDE	STRENGTH	LOCATION (ft)	LOAD COMBO	DURATION FACTOR	CD
Shear Stress Y (psi)	PASS (67.5%)	39.0	120.0	0	D+L	1	
Bending Stress Y (psi)	PASS (61.9%)	357.6	938.4	2.8	D+L	1	
Deflection (in)	PASS (75.3%)	0.008 (=L/1462)	0.033 (=L/360)	6.08	L		
Bearing Stress (psi)	PASS (85.6%)	64.5	448.4	5.58	D+L	1	

REACTIONS

Units for V: lbf Units for M: lbf-ft

Y axis	DEAD	LIVE	LIVE ROOF	SNOW	WIND +	WIND -	SEISMIC +	SEISMIC -	ICE	RAIN	EARTH
A	61	222	0	0	0	0	0	0	0	0	0
B	73	265	0	0	0	0	0	0	0	0	0
C	0	0	0	0	0	0	0	0	0	0	0

Reaction Location

A

B

C

LOAD LIST

Type	Left Magnitude	Right Magnitude	Load Start (ft)	Load End (ft)	Load Type	Direction
Uniform (lbf/ft ²)	60	60	0	6.08334	Live	Y
Uniform (lbf/ft ²)	15	15	0	6.08334	Dead	Y
Self Weight (lbf/ft)	2.15	2.15	0	6.08334	Dead	Y

DATE:	10/18/2021	COMPANY:	Pacific Northwest Structural Group, Inc			
VITRUVIUS BUILD:	Base	DESIGNED BY:	David Starkel			
CUSTOMER:		REVIEWED BY:	David Starkel			
PROJ. ADDRESS:	--	PROJECT NAME:	21-028 Framing			
	--					
LEVEL:	S2.2	LOADING:	ASD			
MEMBER NAME:	DJ4-2.2	CODE:	2018 International Building Code			
MEMBER TYPE:	FLOOR JOIST	NDS:	2018 NDS			
MATERIAL:	Solid Sawn					
Douglas Fir-Larch	No. 1	(1) 1.5 X 9.25	12(in) O.C.	DRY		

DJ4-2.2 DIAGRAM



BEAM PROPERTIES

Start (ft): 0 End (ft): 14.5 Member Slope: 0/12 Actual Length (ft): 14.5 O.C. Spacing(in): 12

Area	Ix	Iy	BSW	Lams	G	Kcr
(in ²)	(in ⁴)	(in ⁴)	(lbf/ft)			Creep Factor
13.88	98.93	2.6	3.16	1	0.5	1

STRENGTH PROPERTIES

	Fb (psi)	Ft (psi)	Fv (psi)	Fc (psi)	Fc⊥ (psi)	E (psi) x10 ³	Emin (psi) x10 ³
Base Values	1000	675	180	1500	625	1700	620
Adjusted Values	1265	742	180	1500	625	1700	620
C _M	1	1	1	1	1	1	1
C _T	1	1	1	1	1	1	1
C _i	1	1	1	1	1	1	1
C _F	1.1	1.1	1	1	1	1	1

Bending Adjustment Factors C_{fu} = 0.74C_r = 1.15

BEAM DATA

Span	Length (ft)	Unbraced Length (ft)		Beam End				
		Top	Bottom	Elev. Diff (ft)	CL(Top)	CL(Bottom)	CL(Left)	CL(Right)
1	14.5	0	14.5	0	1.00	0.48	1.00	1.00

PASS-FAIL

	PASS/FAIL	MAGNITUDE	STRENGTH	LOCATION (ft)	LOAD COMBO	DURATION FACTOR CD
Shear Stress Y (psi)	PASS (67.3%)	58.8	180.0	14.5	D+L	1
Bending Stress Y (psi)	PASS (12.6%)	1105.8	1265.0	7.25	D+L	1
Deflection (in)	PASS (26.6%)	0.355 (=L/490)	0.483 (=L/360)	7.25	L	
Bearing Stress (psi)	PASS (83.4%)	103.6	625.0	0	D+L	1

REACTIONS

Units for V: lbf Units for M: lbf-ft

Y axis	DEAD	LIVE	LIVE ROOF	SNOW	WIND +	WIND -	SEISMIC +	SEISMIC -	ICE	RAIN	EARTH
A	109	435	0	0	0	0	0	0	0	0	0
B	109	435	0	0	0	0	0	0	0	0	0

Reaction Location

A

B

CONNECTORS

(All connectors are Simpson Strong-Tie connectors)*

Support A	Model	Type	Adequacy (%)	Header Fastening (in)	Joist Nails (in)	Nailer Thickness (in)
Primary	LUS210	Hanger	26.12	(8) 0.148 x 3	(4) 0.148 x 3	N/A

Hanger at support A has seat sloped 0 degrees, skewed 0 degrees.

WSR = web stiffeners required

*Capacity values are adjusted based on specific gravity when members use grades other than those specified in Simpson Strong-Tie's capacity tables.

**LOAD LIST**

Type	Left Magnitude	Right Magnitude	Load Start (ft)	Load End (ft)	Load Type	Direction
Uniform (lb/ft ²)	60	60	0	14.5	Live	Y
Uniform (lb/ft ²)	15	15	0	14.5	Dead	Y

DATE:	10/18/2021	COMPANY:	Pacific Northwest Structural Group, Inc			
VITRUVIUS BUILD:	Base	DESIGNED BY:	David Starkel			
CUSTOMER:		REVIEWED BY:	David Starkel			
PROJ. ADDRESS:	--	PROJECT NAME:	21-028 Framing			
	--					
LEVEL:	S2.2	LOADING:	ASD			
MEMBER NAME:	DJ5-2.2	CODE:	2018 International Building Code			
MEMBER TYPE:	FLOOR JOIST	NDS:	2018 NDS			
MATERIAL:	Solid Sawn					
Hem-Fir	No. 2	(1) 1.5 X 9.25	12(in) O.C.	DRY	INCISED	

DJ5-2.2 DIAGRAM



BEAM PROPERTIES

Start (ft): 0 End (ft): 11.333 Member Slope: 0/12 Actual Length (ft): 11.33 O.C. Spacing(in): 12

Area	Ix	Iy	BSW	Lams	G	Kcr
(in ²)	(in ⁴)	(in ⁴)	(lb/ft)			Creep Factor
13.88	98.93	2.6	2.74	1	0.43	1

STRENGTH PROPERTIES

	Fb (psi)	Ft (psi)	Fv (psi)	Fc (psi)	Fc⊥ (psi)	E (psi) x10 ³	Emin (psi) x10 ³
Base Values	850	525	150	1300	405	1300	470
Adjusted Values	860	462	120	1040	405	1235	446
C _M	1	1	1	1	1	1	1
C _T	1	1	1	1	1	1	1
C _i	0.8	0.8	0.8	0.8	1	0.95	0.95
C _F	1.1	1.1	1	1	1	1	1

Bending Adjustment Factors C_{fu} = 1 C_r = 1.15

BEAM DATA

Span	Length (ft)	Unbraced Length (ft)		Beam End				
		Top	Bottom	Elev. Diff (ft)	CL(Top)	CL(Bottom)	CL(Left)	CL(Right)
1	5.3334	0	5.3334	0	1.00	0.97	1.00	1.00
2	6	0	6	0	1.00	0.97	1.00	1.00

PASS-FAIL

	PASS/FAIL	MAGNITUDE	STRENGTH	LOCATION (ft)	LOAD COMBO	DURATION FACTOR	CD
Shear Stress Y (psi)	PASS (57.7%)	50.7	120.0	5.33	D+L	1	
Bending Stress Y (psi)	PASS (6.4%)	783.2	837.1	5.33	D+L	1	
Deflection (in)	PASS (89.1%)	0.019 (=L/3316)	0.178 (=L/360)	3.29	L		
Bearing Stress (psi)	PASS (60.2%)	178.3	448.4	5.33	D+L	1	

REACTIONS

Units for V: lbf Units for M: lbf-ft

Y axis	DEAD	LIVE	LIVE ROOF	SNOW	WIND +	WIND -	SEISMIC +	SEISMIC -	ICE	RAIN	EARTH
A	-13	-42	0	0	0	0	0	0	0	0	0
B	214	722	0	0	0	0	0	0	0	0	0
C	0	0	0	0	0	0	0	0	0	0	0

Reaction Location

A

B

C

CONNECTORS		(All connectors are Simpson Strong-Tie connectors)*			Header	Joist Nails (in)	Nailer
Support A	Model	Type	Adequacy (%)	Fastening (in)		Thickness (in)	
Primary	LUS210	Hanger	86.24	(8) 0.148 x 3	(4) 0.148 x 3	N/A	

Hanger at support A has seat sloped 0 degrees, skewed 0 degrees.

WSR = web stiffeners required

*Capacity values are adjusted based on specific gravity when members use grades other than those specified in Simpson Strong-Tie's capacity tables.



LOAD LIST						
Type	Left Magnitude	Right Magnitude	Load Start (ft)	Load End (ft)	Load Type	Direction
Uniform (lbf/ft ²)	60	60	0	11.3334	Live	Y
Uniform (lbf/ft ²)	15	15	0	11.3334	Dead	Y
Self Weight (lbf/ft)	2.74	2.74	0	11.3334	Dead	Y

DATE:	10/18/2021	COMPANY:	Pacific Northwest Structural Group, Inc		
VITRUVIUS BUILD:	Base	DESIGNED BY:	David Starkel		
CUSTOMER:		REVIEWED BY:	David Starkel		
PROJ. ADDRESS:	-- --	PROJECT NAME:	21-028 Framing		
LEVEL:	S2.2	LOADING:	ASD		
MEMBER NAME:	DJ6-2.2	CODE:	2018 International Building Code		
MEMBER TYPE:	FLOOR JOIST	NDS:	2018 NDS		
MATERIAL:	Solid Sawn				
Hem-Fir	No. 2	(1) 1.5 X 9.25	16(in) O.C.	DRY	INCISED

DJ6-2.2 DIAGRAM



BEAM PROPERTIES

Start (ft): 0 End (ft): 7.25 Member Slope: 0/12 Actual Length (ft): 7.25 O.C. Spacing(in): 16

Area	Ix	Iy	BSW	Lams	G	Kcr
(in ²)	(in ⁴)	(in ⁴)	(lbf/ft)			Creep Factor
13.88	98.93	2.6	2.74	1	0.43	1

STRENGTH PROPERTIES

	Fb (psi)	Ft (psi)	Fv (psi)	Fc (psi)	Fc⊥ (psi)	E (psi) x10 ³	Emin (psi) x10 ³
Base Values	850	525	150	1300	405	1300	470
Adjusted Values	860	462	120	1040	405	1235	446
C _M	1	1	1	1	1	1	1
C _T	1	1	1	1	1	1	1
C _i	0.8	0.8	0.8	0.8	1	0.95	0.95
C _F	1.1	1.1	1	1	1	1	1

Bending Adjustment Factors C_{fu} = 1 C_r = 1.15

BEAM DATA

Span	Length (ft)	Unbraced Length (ft)		Beam End				
		Top	Bottom	Elev. Diff (ft)	CL(Top)	CL(Bottom)	CL(Left)	CL(Right)
1	5	0	5	0	1.00	0.96	1.00	1.00
2	2.25	0	2.25	0	1.00	0.99	1.00	1.00

PASS-FAIL

	PASS/FAIL	MAGNITUDE	STRENGTH	LOCATION (ft)	LOAD COMBO	DURATION FACTOR	CD
Shear Stress Y (psi)	PASS (72.8%)	32.6	120.0	4.93	D+L	1	
Bending Stress Y (psi)	PASS (82.9%)	145.6	853.2	5	D+L	1	
Deflection (in)	PASS (97.1%)	0.005 (=L/12503)	0.167 (=L/360)	2.25	L		
Bearing Stress (psi)	PASS (77.1%)	102.9	448.4	5	D+L	1	

REACTIONS

Units for V: lbf Units for M: lbf-ft

Y axis	DEAD	LIVE	LIVE ROOF	SNOW	WIND +	WIND -	SEISMIC +	SEISMIC -	ICE	RAIN	EARTH
A	45	160	0	0	0	0	0	0	0	0	0
B	120	421	0	0	0	0	0	0	0	0	0
C	0	0	0	0	0	0	0	0	0	0	0

Reaction Location

A

B

C

LOAD LIST

Type	Left Magnitude	Right Magnitude	Load Start (ft)	Load End (ft)	Load Type	Direction
Uniform (lbf/ft ²)	60	60	0	7.25	Live	Y
Uniform (lbf/ft ²)	15	15	0	7.25	Dead	Y
Self Weight (lbf/ft)	2.74	2.74	0	7.25	Dead	Y

DATE:	10/18/2021	COMPANY:	Pacific Northwest Structural Group, Inc			
VITRUVIUS BUILD:	Base	DESIGNED BY:	David Starkel			
CUSTOMER:		REVIEWED BY:	David Starkel			
PROJ. ADDRESS:	--	PROJECT NAME:	21-028 Framing			
	--					
LEVEL:	S2.2	LOADING:	ASD			
MEMBER NAME:	DJ7-2.2	CODE:	2018 International Building Code			
MEMBER TYPE:	FLOOR JOIST	NDS:	2018 NDS			
MATERIAL:	Solid Sawn					
Hem-Fir	No. 2	(1) 1.5 X 11.25	16(in) O.C.	DRY	INCISED	

DJ7-2.2 DIAGRAM



BEAM PROPERTIES

Start (ft): 0 End (ft): 3.667 Member Slope: 0/12 Actual Length (ft): 3.67 O.C. Spacing(in): 16

Area	Ix	Iy	BSW	Lams	G	Kcr
(in ²)	(in ⁴)	(in ⁴)	(lbf/ft)			Creep Factor
16.88	177.98	3.16	3.33	1	0.43	1

STRENGTH PROPERTIES

	Fb (psi)	Ft (psi)	Fv (psi)	Fc (psi)	Fc⊥ (psi)	E (psi) x10 ³	Emin (psi) x10 ³
Base Values	850	525	150	1300	405	1300	470
Adjusted Values	782	420	120	1040	405	1235	446
C _M	1	1	1	1	1	1	1
C _T	1	1	1	1	1	1	1
C _i	0.8	0.8	0.8	0.8	1	0.95	0.95
C _F	1	1	1	1	1	1	1

Bending Adjustment Factors C_{fu} = 1 C_r = 1.15

BEAM DATA

Span	Length (ft)	Unbraced Length (ft)		Beam End				
		Top	Bottom	Elev. Diff (ft)	CL(Top)	CL(Bottom)	CL(Left)	CL(Right)
1	3.16667	0	3.16667	0	1.00	0.96	1.00	1.00
2	0.5	0	0.5	0	1.00	1.00	1.00	1.00

PASS-FAIL

	PASS/FAIL	MAGNITUDE	STRENGTH	LOCATION (ft)	LOAD COMBO	DURATION FACTOR CD
Shear Stress Y (psi)	PASS (87.7%)	14.8	120.0	3.15	D+L	1
Bending Stress Y (psi)	PASS (94.0%)	46.7	782.0	1.54	D+L	1
Deflection (in)	PASS (98.9%)	0.000 (=L/29970)	0.033 (=L/360)	3.67	L	
Bearing Stress (psi)	PASS (90.7%)	41.8	448.4	3.17	D+L	1

REACTIONS

Units for V: lbf Units for M: lbf-ft

Y axis	DEAD	LIVE	LIVE ROOF	SNOW	WIND +	WIND -	SEISMIC +	SEISMIC -	ICE	RAIN	EARTH
A	36	124	0	0	0	0	0	0	0	0	0
B	50	170	0	0	0	0	0	0	0	0	0
C	0	0	0	0	0	0	0	0	0	0	0

Reaction Location



CONNECTORS		(All connectors are Simpson Strong-Tie connectors)*			Header	Joist Nails (in)	Nailer
Support A	Model	Type	Adequacy (%)	Fastening (in)		Thickness (in)	
Primary	LUS210	Hanger	86.13	(8) 0.148 x 3	(4) 0.148 x 3	N/A	

Hanger at support A has seat sloped 0 degrees, skewed 0 degrees.

WSR = web stiffeners required

*Capacity values are adjusted based on specific gravity when members use grades other than those specified in Simpson Strong-Tie's capacity tables.



LOAD LIST						
Type	Left Magnitude	Right Magnitude	Load Start (ft)	Load End (ft)	Load Type	Direction
Uniform (lbf/ft ²)	60	60	0	3.66667	Live	Y
Uniform (lbf/ft ²)	15	15	0	3.66667	Dead	Y
Self Weight (lbf/ft)	3.33	3.33	0	3.66667	Dead	Y

DATE:	10/18/2021	COMPANY:	Pacific Northwest Structural Group, Inc
VITRUVIUS BUILD:	Base	DESIGNED BY:	David Starkel
CUSTOMER:		REVIEWED BY:	David Starkel
PROJ. ADDRESS:	-- --	PROJECT NAME:	21-028 Framing
LEVEL:	S2.2	LOADING:	ASD
MEMBER NAME:	FB1-2.2	CODE:	2018 International Building Code
MEMBER TYPE:	FLOOR BEAM	NDS:	2018 NDS
MATERIAL:	Glulams		
Stress Class Rated 24F-1.8E	24F-V4 DF/DF	(1) 3.5 X 9	DRY

FB1-2.2 DIAGRAM



BEAM PROPERTIES

Start (ft): 0 End (ft): 11 Member Slope: 0/12 Actual Length (ft): 11

Area	Ix	Iy	BSW	Lams	G	Kcr
(in ²)	(in ⁴)	(in ⁴)	(lbf/ft)			Creep Factor
31.5	212.62	32.16	7.18	1	0.5	1

STRENGTH PROPERTIES

	Fbx+	Fbx-	Fby	Ft	Fvx	Fvy	Fc	Fc⊥	Ex	Exmin	Ey	Eymin
	(psi)	(psi)	(psi)	(psi)	(psi)	(psi)	(psi)	(psi)	(psi)	(psi)	(psi)	(psi)
Base Values	2400	1850	1450	1100	265	230	1650	650	1800000	950000	1600000	850000
Adjusted Values	2400	1850	1497	1100	265	230	1650	650	1800000	950000	1600000	850000
C _M	1	1	1	1	1	1	1	1	1	1	1	1
C _T	1	1	1	1	1	1	1	1	1	1	1	1

Bending Adjustment Factors C_{vr} = 1

BEAM DATA

Span	Length (ft)	Unbraced Length (ft)		Beam End				
		Top	Bottom	Elev. Diff (ft)	CL(Top)	CL(Bottom)	CL(Left)	CL(Right)
1	11	0	11	0	1.00	0.98	1.00	1.00

PASS-FAIL

	PASS/FAIL	MAGNITUDE	STRENGTH	LOCATION (ft)	LOAD COMBO	DURATION FACTOR CD
Shear Stress Y (psi)	PASS (66.1%)	103.3	304.8	0	D+S	1.15
Bending Stress Y (psi)	PASS (52.4%)	1312.7	2760.0	4.84	D+0.75L+0.75S	1.15
Deflection (in)	PASS (54.0%)	0.253 (=L/522)	0.550 (=L/240)	5.28	D+Lr	
Bearing Stress (psi)	PASS (72.8%)	177.0	650.0	0	D+S	1.15

REACTIONS

Y axis	DEAD	LIVE	LIVE ROOF	SNOW	WIND +	WIND -	SEISMIC +	SEISMIC -	ICE	RAIN	EARTH
A	1175	293	795	993	0	0	0	0	0	0	0
B	612	293	358	447	0	0	0	0	0	0	0

Reaction Location

A

B

LOAD LIST

Type	Left Magnitude	Right Magnitude	Load Start (ft)	Load End (ft)	Load Type	Direction
Uniform (lbf/ft)	53.33	53.33	0	11	Live	Y
Uniform (lbf/ft)	20	20	0	11	Dead	Y
Uniform (lbf/ft)	75	75	0	6.8334	Dead	Y
Self Weight (lbf/ft)	7.18	7.18	0	11	Dead	Y

LINKED LOAD LIST

Type	Left Magnitude	Right Magnitude	Load Start (ft)	Load End (ft)	Load Type	Direction
Uniform (lbf/ft)	142.7186	142.7186	0	6.8334	Dead	Y
Uniform (lbf/ft)	210.8185	210.8185	0	6.8334	Snow	Y
Uniform (lbf/ft)	168.6548	168.6548	0	6.8334	Roof Live	Y

DATE:	10/18/2021	COMPANY:	Pacific Northwest Structural Group, Inc
VITRUVIUS BUILD:	Base	DESIGNED BY:	David Starkel
CUSTOMER:		REVIEWED BY:	David Starkel
PROJ. ADDRESS:	-- --	PROJECT NAME:	21-028 Framing
LEVEL:	S2.2	LOADING:	ASD
MEMBER NAME:	FB2-2.2	CODE:	2018 International Building Code
MEMBER TYPE:	FLOOR BEAM	NDS:	2018 NDS
MATERIAL:	Solid Sawn		
Douglas Fir-Larch	No. 2	(1) 3.5 X 9.25	DRY

FB2-2.2 DIAGRAM



BEAM PROPERTIES

Start (ft): 0 End (ft): 11 Member Slope: 0/12 Actual Length (ft): 11

Area	Ix	Iy	BSW	Lams	G	Kcr
(in ²)	(in ⁴)	(in ⁴)	(lbf/ft)			Creep Factor
32.38	230.84	33.05	7.38	1	0.5	1

STRENGTH PROPERTIES

	Fb (psi)	Ft (psi)	Fv (psi)	Fc (psi)	Fc⊥ (psi)	E (psi) x10 ³	Emin (psi) x10 ³
Base Values	900	575	180	1350	625	1600	580
Adjusted Values	1080	632	180	1350	625	1600	580
C _M	1	1	1	1	1	1	1
C _T	1	1	1	1	1	1	1
C _i	1	1	1	1	1	1	1
C _F	1.2	1.1	1	1	1	1	1

Bending Adjustment Factors C_{fu} = 1 C_r = 1

BEAM DATA

Span	Length (ft)	Unbraced Length (ft)		Beam End				
		Top	Bottom	Elev. Diff (ft)	CL(Top)	CL(Bottom)	CL(Left)	CL(Right)
1	11	0	11	0	1.00	0.98	1.00	1.00

PASS-FAIL

	PASS/FAIL	MAGNITUDE	STRENGTH	LOCATION (ft)	LOAD COMBO	DURATION FACTOR CD
Shear Stress Y (psi)	PASS (76.3%)	49.0	207.0	11	D+0.75L+0.75S	1.15
Bending Stress Y (psi)	PASS (26.2%)	917.1	1242.0	6.82	D+0.75L+0.75S	1.15
Deflection (in)	PASS (70.6%)	0.162 (=L/817)	0.550 (=L/240)	5.83	D+Lr	
Bearing Stress (psi)	PASS (86.2%)	86.3	625.0	11	D+0.75L+0.75S	1.15

REACTIONS

Units for V: lbf Units for M: lbf-ft

Y axis	DEAD	LIVE	LIVE ROOF	SNOW	WIND +	WIND -	SEISMIC +	SEISMIC -	ICE	RAIN	EARTH
A	341	293	244	305	0	0	0	0	0	0	0
B	462	293	399	500	0	0	0	0	0	0	0

Reaction Location

A

B

LOAD LIST

Type	Left Magnitude	Right Magnitude	Load Start (ft)	Load End (ft)	Load Type	Direction
Uniform (lbf/ft)	53.33	53.33	0	11	Live	Y
Uniform (lbf/ft)	20	20	0	11	Dead	Y
Self Weight (lbf/ft)	7.38	7.38	0	11	Dead	Y

LINKED LOAD LIST

Type	Left Magnitude	Right Magnitude	Load Start (ft)	Load End (ft)	Load Type	Direction
Point (lbf)	501.7554	-	6.8334	-	Dead	Y
Point (lbf)	804.0684	-	6.8334	-	Snow	Y
Point (lbf)	643.0063	-	6.8334	-	Roof Live	Y

DATE:	10/18/2021	COMPANY:	Pacific Northwest Structural Group, Inc			
VITRUVIUS BUILD:	Base	DESIGNED BY:	David Starkel			
CUSTOMER:		REVIEWED BY:	David Starkel			
PROJ. ADDRESS:	--	PROJECT NAME:	21-028 Framing			
	--					
LEVEL:	S2.2	LOADING:	ASD			
MEMBER NAME:	FJ3-2.2	CODE:	2018 International Building Code			
MEMBER TYPE:	FLOOR JOIST	NDS:	2018 NDS			
MATERIAL:	Solid Sawn					
Douglas Fir-Larch	No. 1	(1) 1.5 X 9.25	16(in) O.C.	DRY		

FJ3-2.2 DIAGRAM



BEAM PROPERTIES

Start (ft): 0 End (ft): 14.667 Member Slope: 0/12 Actual Length (ft): 14.67 O.C. Spacing(in): 16

Area	I _x	I _y	BSW	Lams	G	K _{cr}
(in ²)	(in ⁴)	(in ⁴)	(lbf/ft)			Creep Factor
13.88	98.93	2.6	3.16	1	0.5	1

STRENGTH PROPERTIES

	F _b (psi)	F _t (psi)	F _v (psi)	F _c (psi)	F _{c⊥} (psi)	E (psi) x10 ³	E _{min} (psi) x10 ³
Base Values	1000	675	180	1500	625	1700	620
Adjusted Values	1265	742	180	1500	625	1700	620
C _M	1	1	1	1	1	1	1
C _T	1	1	1	1	1	1	1
C _i	1	1	1	1	1	1	1
C _F	1.1	1.1	1	1	1	1	1

Bending Adjustment Factors C_{fu} = 0.74C_r = 1.15

BEAM DATA

Span	Length (ft)	Unbraced Length (ft)		Beam End				
		Top	Bottom	Elev. Diff (ft)	CL(Top)	CL(Bottom)	CL(Left)	CL(Right)
1	14.6667	0	14.6667	0	1.00	0.48	1.00	1.00

PASS-FAIL

	PASS/FAIL	MAGNITUDE	STRENGTH	LOCATION (ft)	LOAD COMBO	DURATION FACTOR CD
Shear Stress Y (psi)	PASS (66.3%)	60.6	180.0	14.67	D+L	1
Bending Stress Y (psi)	PASS (8.8%)	1153.9	1265.0	7.33	D+L	1
Deflection (in)	PASS (32.5%)	0.330 (=L/533)	0.489 (=L/360)	7.33	L	
Bearing Stress (psi)	PASS (82.9%)	106.9	625.0	0	D+L	1

REACTIONS

Units for V: lbf Units for M: lbf-ft

Y axis	DEAD	LIVE	LIVE ROOF	SNOW	WIND +	WIND -	SEISMIC +	SEISMIC -	ICE	RAIN	EARTH
A	170	391	0	0	0	0	0	0	0	0	0
B	170	391	0	0	0	0	0	0	0	0	0

Reaction Location

A

B

CONNECTORS		(All connectors are Simpson Strong-Tie connectors)*			Header	Joist Nails (in)	Nailer
Support A	Model	Type	Adequacy (%)	Fastening (in)		Thickness (in)	
Primary	LUS210	Hanger	57.98	(8) 0.148 x 3	(4) 0.148 x 3	N/A	

Hanger at support A has seat sloped 0 degrees, skewed 0 degrees.

WSR = web stiffeners required

*Capacity values are adjusted based on specific gravity when members use grades other than those specified in Simpson Strong-Tie's capacity tables.



LOAD LIST						
Type	Left Magnitude	Right Magnitude	Load Start (ft)	Load End (ft)	Load Type	Direction
Uniform (lb/ft ²)	40	40	0	14.6667	Live	Y
Uniform (lb/ft ²)	15	15	0	14.6667	Dead	Y
Self Weight (lb/ft)	3.16	3.16	0	14.6667	Dead	Y

DATE:	10/18/2021	COMPANY:	Pacific Northwest Structural Group, Inc
VITRUVIUS BUILD:	Base	DESIGNED BY:	David Starkel
CUSTOMER:		REVIEWED BY:	David Starkel
PROJ. ADDRESS:	-- --	PROJECT NAME:	21-028 Framing
LEVEL:	S2.2	LOADING:	ASD
MEMBER NAME:	FB4-2.2	CODE:	2018 International Building Code
MEMBER TYPE:	FLOOR BEAM	NDS:	2018 NDS
MATERIAL:	Glulams		
Stress Class Rated 24F-1.8E	24F-V4 DF/DF	(1) 3.5 X 9	DRY

FB4-2.2 DIAGRAM



BEAM PROPERTIES

Start (ft): 0 End (ft): 6.5 Member Slope: 0/12 Actual Length (ft): 6.5

Area	Ix	Iy	BSW	Lams	G	Kcr
(in ²)	(in ⁴)	(in ⁴)	(lbf/ft)			Creep Factor
31.5	212.62	32.16	7.18	1	0.5	1

STRENGTH PROPERTIES

	Fbx+	Fbx-	Fby	Ft	Fvx	Fvy	Fc	Fc⊥	Ex	Exmin	Ey	Eymin
	(psi)	(psi)	(psi)	(psi)	(psi)	(psi)	(psi)	(psi)	(psi)	(psi)	(psi)	(psi)
Base Values	2400	1850	1450	1100	265	230	1650	650	1800000	950000	1600000	850000
Adjusted Values	2400	1850	1497	1100	265	230	1650	650	1800000	950000	1600000	850000
C _M	1	1	1	1	1	1	1	1	1	1	1	1
C _T	1	1	1	1	1	1	1	1	1	1	1	1
Bending Adjustment Factors	C _{VR} = 1											

BEAM DATA

Span	Length (ft)	Unbraced Length (ft)		Beam End				
		Top	Bottom	Elev. Diff (ft)	CL(Top)	CL(Bottom)	CL(Left)	CL(Right)
1	6.5	0	6.5	0	1.00	0.99	1.00	1.00

PASS-FAIL

	PASS/FAIL	MAGNITUDE	STRENGTH	LOCATION (ft)	LOAD COMBO	DURATION FACTOR CD
Shear Stress Y (psi)	PASS (25.0%)	198.8	265.0	0	D+L	1
Bending Stress Y (psi)	PASS (28.2%)	1722.5	2400.0	3.25	D+L	1.25
Shear Stress X (psi)	PASS (100.0%)	0.1	287.5	0	D+Lr	1
Bending Stress X (psi)	PASS (99.9%)	1.2	1870.6	3.25	D+Lr	1.25
Deflection (in)	PASS (58.5%)	0.135 (=L/579)	0.325 (=L/240)	3.25	D+L	
Bearing Stress (psi)	PASS (44.5%)	360.7	650.0	0	D+0.75L+0.75Lr	1.25

REACTIONS

Units for V: lbf Units for M: lbf-ft

Y axis	DEAD	LIVE	LIVE ROOF	SNOW	WIND +	WIND -	SEISMIC +	SEISMIC -	ICE	RAIN	EARTH
A	1893	2280	1087	679	0	0	0	0	0	0	0
B	1893	2280	1087	679	0	0	0	0	0	0	0
X axis											
A	0	0	1	0	0	0	0	0	0	0	0
B	0	0	1	0	0	0	0	0	0	0	0

Reaction Location

A

B

LOAD LIST

Type	Left Magnitude	Right Magnitude	Load Start (ft)	Load End (ft)	Load Type	Direction
Uniform (lbf/ft)	100	100	0	6.5	Dead	Y
Self Weight (lbf/ft)	7.18	7.18	0	6.5	Dead	Y

LINKED LOAD LIST

Type	Left Magnitude	Right Magnitude	Load Start (ft)	Load End (ft)	Load Type	Direction
Uniform (lbf/ft)	-0.1481476	-0.1481476	0	6.5	Dead	X
Uniform (lbf/ft)	250.8287	250.8287	0	6.5	Dead	Y
Uniform (lbf/ft)	208.9823	208.9823	0	6.5	Snow	Y
Uniform (lbf/ft)	-0.1975431	-0.1975431	0	6.5	Roof Live	X
Uniform (lbf/ft)	334.3967	334.3967	0	6.5	Roof Live	Y
Uniform (lbf/ft)	108.75	108.75	0	6.5	Dead	Y
Uniform (lbf/ft)	435	435	0	6.5	Live	Y
Uniform (lbf/ft)	115.8231	115.8231	0	6.5	Dead	Y
Uniform (lbf/ft)	266.6683	266.6683	0	6.5	Live	Y

DATE:	10/18/2021	COMPANY:	Pacific Northwest Structural Group, Inc
VITRUVIUS BUILD:	Base	DESIGNED BY:	David Starkel
CUSTOMER:		REVIEWED BY:	David Starkel
PROJ. ADDRESS:	-- --	PROJECT NAME:	21-028 Framing
LEVEL:	S2.2	LOADING:	ASD
MEMBER NAME:	FB5-2.2	CODE:	2018 International Building Code
MEMBER TYPE:	FLOOR BEAM	NDS:	2018 NDS
MATERIAL:	Glulams		
Stress Class Rated 24F-1.8E	24F-V4 DF/DF	(1) 5.5 X 10.5	DRY

FB5-2.2 DIAGRAM



BEAM PROPERTIES

Start (ft): 0 End (ft): 13.833 Member Slope: 0/12 Actual Length (ft): 13.83

Area	Ix	Iy	BSW	Lams	G	Kcr
(in ²)	(in ⁴)	(in ⁴)	(lbf/ft)			Creep Factor
57.75	530.58	145.58	13.17	1	0.5	1

STRENGTH PROPERTIES

	Fbx+	Fbx-	Fby	Ft	Fvx	Fvy	Fc	Fc _⊥	Ex	Exmin	Ey	Eymin
	(psi)	(psi)	(psi)	(psi)	(psi)	(psi)	(psi)	(psi)	(psi)	(psi)	(psi)	(psi)
Base Values	2400	1850	1450	1100	265	230	1650	650	1800000	950000	1600000	850000
Adjusted Values	2400	1850	1472	1100	265	230	1650	650	1800000	950000	1600000	850000
C _M	1	1	1	1	1	1	1	1	1	1	1	1
C _T	1	1	1	1	1	1	1	1	1	1	1	1

Bending Adjustment Factors C_{vr} = 1

BEAM DATA

Span	Length (ft)	Unbraced Length (ft)		Beam End				
		Top	Bottom	Elev. Diff (ft)	CL(Top)	CL(Bottom)	CL(Left)	CL(Right)
1	13.83334	0	13.83334	0	1.00	0.99	1.00	1.00

PASS-FAIL

	PASS/FAIL	MAGNITUDE	STRENGTH	LOCATION (ft)	LOAD COMBO	DURATION FACTOR CD
Shear Stress Y (psi)	PASS (60.2%)	131.9	331.3	13.83	D+Lr	1.25
Bending Stress Y (psi)	PASS (56.7%)	1300.1	3000.0	10.93	D+Lr	1.25
Shear Stress X (psi)	PASS (100.0%)	0.1	287.5	13.83	D+Lr	1.25
Bending Stress X (psi)	PASS (99.9%)	0.9	1837.8	11.21	D+Lr	1.25
Deflection (in)	PASS (53.2%)	0.324 (=L/513)	0.692 (=L/240)	7.61	D+Lr	
Bearing Stress (psi)	PASS (59.4%)	263.8	650.0	13.83	D+Lr	1.25

REACTIONS

Units for V: lbf Units for M: lbf-ft

Y axis	DEAD	LIVE	LIVE ROOF	SNOW	WIND +	WIND -	SEISMIC +	SEISMIC -	ICE	RAIN	EARTH
A	1222	369	1296	810	0	0	0	0	0	0	0
B	2342	369	2736	1710	0	0	0	0	0	0	0
X axis											
A	0	0	1 / 0	0	0	0	0	0	0	0	0
B	1	0	2 / -1	0	0	0	0	0	0	0	0

Reaction Location

A

B

LOAD LIST

Type	Left Magnitude	Right Magnitude	Load Start (ft)	Load End (ft)	Load Type	Direction
Uniform (lb/ft)	53.3	53.3	0	13.83334	Live	Y
Uniform (lb/ft)	20	20	0	13.83334	Dead	Y
Self Weight (lb/ft)	13.17	13.17	0	13.83334	Dead	Y

LINKED LOAD LIST

Type	Left Magnitude	Right Magnitude	Load Start (ft)	Load End (ft)	Load Type	Direction
Uniform (lb/ft)	0.3275461	0.3275461	0	1.41667	Dead	X
Uniform (lb/ft)	0.3275461	0.3275461	11	13.83334	Dead	X
Uniform (lb/ft)	203.1002	203.1002	0	1.41667	Dead	Y
Uniform (lb/ft)	203.1002	203.1002	11	13.83334	Dead	Y
Uniform (lb/ft)	0.6063387	0.6063387	0	1.41667	Snow	X
Uniform (lb/ft)	0.6063387	0.6063387	11	13.83334	Snow	X
Uniform (lb/ft)	169.3124	169.3124	0	1.41667	Snow	Y
Uniform (lb/ft)	169.3124	169.3124	11	13.83334	Snow	Y
Uniform (lb/ft)	0.2700491	0.2700491	0	1.41667	Roof Live	X
Uniform (lb/ft)	0.2700491	0.2700491	11	13.83334	Roof Live	X
Uniform (lb/ft)	270.8003	270.8003	0	1.41667	Roof Live	Y
Uniform (lb/ft)	270.8003	270.8003	11	13.83334	Roof Live	Y
Uniform (lb/ft)	-0.6244926	-0.6244926	0	1.41667	Dead	X
Uniform (lb/ft)	-0.6244926	-0.6244926	11	13.83334	Dead	X
Uniform (lb/ft)	144.517	144.517	0	1.41667	Dead	Y
Uniform (lb/ft)	144.517	144.517	11	13.83334	Dead	Y
Uniform (lb/ft)	-0.4851565	-0.4851565	0	1.41667	Snow	X
Uniform (lb/ft)	-0.4851565	-0.4851565	11	13.83334	Snow	X
Uniform (lb/ft)	120.4367	120.4367	0	1.41667	Snow	Y
Uniform (lb/ft)	120.4367	120.4367	11	13.83334	Snow	Y
Uniform (lb/ft)	-0.9031782	-0.9031782	0	1.41667	Roof Live	X
Uniform (lb/ft)	-0.9031782	-0.9031782	11	13.83334	Roof Live	X
Uniform (lb/ft)	192.6777	192.6777	0	1.41667	Roof Live	Y
Uniform (lb/ft)	192.6777	192.6777	11	13.83334	Roof Live	Y
Point (lb)	132.0047	-	1.41667	-	Dead	Y
Point (lb)	1496.188	-	11	-	Dead	Y
Point (lb)	104.5029	-	1.41667	-	Snow	Y
Point (lb)	1184.473	-	11	-	Snow	Y
Point (lb)	167.1921	-	1.41667	-	Roof Live	Y
Point (lb)	1895.015	-	11	-	Roof Live	Y

DATE:	10/18/2021	COMPANY:	Pacific Northwest Structural Group, Inc
VITRUVIUS BUILD:	Base	DESIGNED BY:	David Starkel
CUSTOMER:		REVIEWED BY:	David Starkel
PROJ. ADDRESS:	-- --	PROJECT NAME:	21-028 Framing
LEVEL:	S2.2	LOADING:	ASD
MEMBER NAME:	FB7-2.2	CODE:	2018 International Building Code
MEMBER TYPE:	FLOOR BEAM	NDS:	2018 NDS
MATERIAL:	Glulams		
Stress Class Rated 24F-1.8E	24F-V4 DF/DF	(1) 3.5 X 9	DRY

FB7-2.2 DIAGRAM



BEAM PROPERTIES

Start (ft): 0 End (ft): 20.083 Member Slope: 0/12 Actual Length (ft): 20.08

Area	Ix	Iy	BSW	Lams	G	Kcr
(in ²)	(in ⁴)	(in ⁴)	(lbf/ft)			Creep Factor
31.5	212.62	32.16	7.18	1	0.5	1

STRENGTH PROPERTIES

	Fbx+	Fbx-	Fby	Ft	Fvx	Fvy	Fc	Fc⊥	Ex	Exmin	Ey	Eymin
	(psi)	(psi)	(psi)	(psi)	(psi)	(psi)	(psi)	(psi)	(psi)	(psi)	(psi)	(psi)
Base Values	2400	1850	1450	1100	265	230	1650	650	1800000	950000	1600000	850000
Adjusted Values	2400	1850	1497	1100	265	230	1650	650	1800000	950000	1600000	850000
C _M	1	1	1	1	1	1	1	1	1	1	1	1
C _T	1	1	1	1	1	1	1	1	1	1	1	1
Bending Adjustment Factors	C _{VR} = 1											

BEAM DATA

Span	Length (ft)	Unbraced Length (ft)		Beam End				
		Top	Bottom	Elev. Diff (ft)	CL(Top)	CL(Bottom)	CL(Left)	CL(Right)
1	13.3334	0	13.3334	0	1.00	0.98	1.00	1.00
2	6.750001	0	6.75	0	1.00	1.00	1.00	1.00

PASS-FAIL

	PASS/FAIL	MAGNITUDE	STRENGTH	LOCATION (ft)	LOAD COMBO	DURATION FACTOR	CD
Shear Stress Y (psi)	PASS (56.6%)	114.9	265.0	13.46	D+L	1	
Bending Stress Y (psi)	PASS (29.2%)	1287.5	1819.6	13.26	D+L	1	
Deflection (in)	PASS (57.7%)	0.282 (=L/568)	0.667 (=L/240)	6.03	D+L		
Bearing Stress (psi)	PASS (45.5%)	392.4	719.6	13.33	D+L	1	

REACTIONS

Units for V: lbf Units for M: lbf-ft

Y axis	DEAD	LIVE	LIVE ROOF	SNOW	WIND +	WIND -	SEISMIC +	SEISMIC -	ICE	RAIN	EARTH
A	919	626 / -33	0	271	0	0	0	0	0	0	0
B	2570	2237	0	688	0	0	0	0	0	0	0
C	330	719	0	45	0	0	0	0	0	0	0

Reaction Location

A

B

C

LOAD LIST

Type	Left Magnitude	Right Magnitude	Load Start (ft)	Load End (ft)	Load Type	Direction
Uniform (lbf/ft)	50	50	0	20.0834	Snow	Y
Uniform (lbf/ft)	130	130	0	20.0834	Dead	Y
Uniform (lbf/ft)	275	275	13.3334	20.0834	Live	Y
Uniform (lbf/ft)	103	103	13.3334	20.0834	Dead	Y
Self Weight (lbf/ft)	7.18	7.18	0	20.0834	Dead	Y

LINKED LOAD LIST

Type	Left Magnitude	Right Magnitude	Load Start (ft)	Load End (ft)	Load Type	Direction
Uniform (lbf/ft)	-12.5627	-12.5627	13.3334	20.0834	Dead	Y
Uniform (lbf/ft)	-42.49428	-42.49428	13.3334	20.0834	Live	Y
Uniform (lbf/ft)	34.00035	34.00035	0	13.3334	Dead	Y
Uniform (lbf/ft)	119.625	119.625	0	13.3334	Live	Y

DATE:	10/18/2021	COMPANY:	Pacific Northwest Structural Group, Inc
VITRUVIUS BUILD:	Base	DESIGNED BY:	David Starkel
CUSTOMER:		REVIEWED BY:	David Starkel
PROJ. ADDRESS:	-- --	PROJECT NAME:	21-028 Framing
LEVEL:	S2.2	LOADING:	ASD
MEMBER NAME:	FB8-2.2	CODE:	2018 International Building Code
MEMBER TYPE:	FLOOR BEAM	NDS:	2018 NDS
MATERIAL:	Glulams		
Stress Class Rated 24F-1.8E	24F-V4 DF/DF	(1) 5.5 X 9	DRY

FB8-2.2 DIAGRAM



BEAM PROPERTIES

Start (ft): 0 End (ft): 12.667 Member Slope: 0/12 Actual Length (ft): 12.67

Area	Ix	Iy	BSW	Lams	G	Kcr
(in ²)	(in ⁴)	(in ⁴)	(lbf/ft)			Creep Factor
49.5	334.12	124.78	11.29	1	0.5	1

STRENGTH PROPERTIES

	Fbx+	Fbx-	Fby	Ft	Fvx	Fvy	Fc	Fc _⊥	Ex	Exmin	Ey	Eymin
	(psi)	(psi)	(psi)	(psi)	(psi)	(psi)	(psi)	(psi)	(psi)	(psi)	(psi)	(psi)
Base Values	2400	1850	1450	1100	265	230	1650	650	1800000	950000	1600000	850000
Adjusted Values	2400	1850	1497	1100	265	230	1650	650	1800000	950000	1600000	850000
C _M	1	1	1	1	1	1	1	1	1	1	1	1
C _T	1	1	1	1	1	1	1	1	1	1	1	1
Bending Adjustment Factors	C _{vr} = 1											

BEAM DATA

Span	Length (ft)	Unbraced Length (ft)		Beam End				
		Top	Bottom	Elev. Diff (ft)	CL(Top)	CL(Bottom)	CL(Left)	CL(Right)
1	12.6667	0	12.6667	0	1.00	0.99	1.00	1.00

PASS-FAIL

	PASS/FAIL	MAGNITUDE	STRENGTH	LOCATION (ft)	LOAD COMBO	DURATION FACTOR	CD
Shear Stress Y (psi)	PASS (69.9%)	79.9	265.0	12.67	D+L	1	1
Bending Stress Y (psi)	PASS (43.8%)	1349.4	2400.0	6.33	D+L	1	1
Deflection (in)	PASS (28.1%)	0.304 (=L/500)	0.422 (=L/360)	6.33	L		
Bearing Stress (psi)	PASS (78.9%)	137.0	650.0	12.67	D+L	1	1

REACTIONS

Units for V: lbf Units for M: lbf-ft

Y axis	DEAD	LIVE	LIVE ROOF	SNOW	WIND +	WIND -	SEISMIC +	SEISMIC -	ICE	RAIN	EARTH
A	639	1997	0	0	0	0	0	0	0	0	0
B	639	1997	0	0	0	0	0	0	0	0	0

Reaction Location

A

B

LOAD LIST

Type	Left Magnitude	Right Magnitude	Load Start (ft)	Load End (ft)	Load Type	Direction
Self Weight (lbf/ft)	11.29	11.29	0	12.6667	Dead	Y

LINKED LOAD LIST

Type	Left Magnitude	Right Magnitude	Load Start (ft)	Load End (ft)	Load Type	Direction
Uniform (lb/ft)	89.63728	89.63728	0	12.6667	Dead	Y
Uniform (lb/ft)	315.375	315.375	0	12.6667	Live	Y

DATE:	10/18/2021	COMPANY:	Pacific Northwest Structural Group, Inc
VITRUVIUS BUILD:	Base	DESIGNED BY:	David Starkel
CUSTOMER:		REVIEWED BY:	David Starkel
PROJ. ADDRESS:	--	PROJECT NAME:	21-028 Framing
	--		
LEVEL:	S2.2	LOADING:	ASD
MEMBER NAME:	FB9-2.2	CODE:	2018 International Building Code
MEMBER TYPE:	FLOOR BEAM	NDS:	2018 NDS
MATERIAL:	Glulams		
Stress Class Rated 24F-1.8E	24F-V4 DF/DF	(1) 5.5 X 12	DRY

FB9-2.2 DIAGRAM



BEAM PROPERTIES

Start (ft): 0 End (ft): 12.5 Member Slope: 0/12 Actual Length (ft): 12.5

Area	Ix	Iy	BSW	Lams	G	Kcr
(in ²)	(in ⁴)	(in ⁴)	(lbf/ft)			Creep Factor
66	792	166.38	15.05	1	0.5	1

STRENGTH PROPERTIES

	Fbx+	Fbx-	Fby	Ft	Fvx	Fvy	Fc	Fc _⊥	Ex	Exmin	Ey	Eymin
	(psi)	(psi)	(psi)	(psi)	(psi)	(psi)	(psi)	(psi)	(psi)	(psi)	(psi)	(psi)
Base Values	2400	1850	1450	1100	265	230	1650	650	1800000	950000	1600000	850000
Adjusted Values	2400	1850	1450	1100	265	230	1650	650	1800000	950000	1600000	850000
C _M	1	1	1	1	1	1	1	1	1	1	1	1
C _T	1	1	1	1	1	1	1	1	1	1	1	1

Bending Adjustment Factors C_{VR} = 1

BEAM DATA

Span	Length (ft)	Unbraced Length (ft)		Beam End				
		Top	Bottom	Elev. Diff (ft)	CL(Top)	CL(Bottom)	CL(Left)	CL(Right)
1	12.5	0	12.5	0	1.00	0.99	1.00	1.00

PASS-FAIL

	PASS/FAIL	MAGNITUDE	STRENGTH	LOCATION (ft)	LOAD COMBO	DURATION FACTOR CD
Shear Stress Y (psi)	PASS (2.8%)	257.6	265.0	0	D+L	1
Bending Stress Y (psi)	PASS (47.0%)	1271.8	2400.0	5.5	D+L	1
Deflection (in)	PASS (54.6%)	0.284 (=L/529)	0.625 (=L/240)	6	D+L	
Bearing Stress (psi)	PASS (1.8%)	638.2	650.0	0	D+0.75L+0.75S	1.15

REACTIONS

Units for V: lbf Units for M: lbf-ft

Y axis	DEAD	LIVE	LIVE ROOF	SNOW	WIND +	WIND -	SEISMIC +	SEISMIC -	ICE	RAIN	EARTH
A	5406	5928	2596	3245	0	0	0	0	0	0	0
B	1424	2557	678	847	0	0	0	0	0	0	0

Reaction Location

A

B

LOAD LIST

Type	Left Magnitude	Right Magnitude	Load Start (ft)	Load End (ft)	Load Type	Direction
Self Weight (lbf/ft)	15.05	15.05	0	12.5	Dead	Y

LINKED LOAD LIST

Type	Left Magnitude	Right Magnitude	Load Start (ft)	Load End (ft)	Load Type	Direction
Uniform (lbf/ft)	80.34286	80.34286	0.6667	12.5	Dead	Y
Uniform (lbf/ft)	112.2963	112.2963	0.6667	12.5	Snow	Y
Uniform (lbf/ft)	89.83692	89.83692	0.6667	12.5	Roof Live	Y
Uniform (lbf/ft)	94.22628	94.22628	0	12.5	Dead	Y
Uniform (lbf/ft)	376.9051	376.9051	0	12.5	Live	Y
Point (lbf)	4513.849	-	0.6667	-	Dead	Y
Point (lbf)	3773.249	-	0.6667	-	Live	Y
Point (lbf)	2763.24	-	0.6667	-	Snow	Y
Point (lbf)	2210.709	-	0.6667	-	Roof Live	Y

DATE:	10/18/2021	COMPANY:	Pacific Northwest Structural Group, Inc		
VITRUVIUS BUILD:	Base	DESIGNED BY:	David Starkel		
CUSTOMER:		REVIEWED BY:	David Starkel		
PROJ. ADDRESS:	--	PROJECT NAME:	21-028 Framing		
	--				
LEVEL:	S2.2	LOADING:	ASD		
MEMBER NAME:	FJ1-2.2	CODE:	2018 International Building Code		
MEMBER TYPE:	FLOOR JOIST	NDS:	2018 NDS		
MATERIAL:	Solid Sawn				
Douglas Fir-Larch	No. 2	(1) 1.5 X 9.25	16(in) O.C.	DRY	

FJ1-2.2 DIAGRAM



BEAM PROPERTIES

Start (ft): 0 End (ft): 12.75 Member Slope: 0/12 Actual Length (ft): 12.75 O.C. Spacing(in): 16

Area	Ix	Iy	BSW	Lams	G	Kcr
(in ²)	(in ⁴)	(in ⁴)	(lbf/ft)			Creep Factor
13.88	98.93	2.6	3.16	1	0.5	1

STRENGTH PROPERTIES

	Fb (psi)	Ft (psi)	Fv (psi)	Fc (psi)	Fc⊥ (psi)	E (psi) x10 ³	Emin (psi) x10 ³
Base Values	900	575	180	1350	625	1600	580
Adjusted Values	1138	632	180	1350	625	1600	580
C _M	1	1	1	1	1	1	1
C _T	1	1	1	1	1	1	1
C _i	1	1	1	1	1	1	1
C _F	1.1	1.1	1	1	1	1	1

Bending Adjustment Factors C_{fu} = 1 C_r = 1.15

BEAM DATA

Span	Length (ft)	Unbraced Length (ft)		Beam End				
		Top	Bottom	Elev. Diff (ft)	CL(Top)	CL(Bottom)	CL(Left)	CL(Right)
1	12.75	0	12.75	0	1.00	0.56	1.00	1.00

PASS-FAIL

	PASS/FAIL	MAGNITUDE	STRENGTH	LOCATION (ft)	LOAD COMBO	DURATION FACTOR CD
Shear Stress Y (psi)	PASS (70.7%)	52.7	180.0	0	D+L	1
Bending Stress Y (psi)	PASS (23.4%)	872.0	1138.5	6.38	D+L	1
Deflection (in)	PASS (52.9%)	0.200 (=L/764)	0.425 (=L/360)	6.38	L	
Bearing Stress (psi)	PASS (85.1%)	92.9	625.0	0	D+L	1

REACTIONS

Units for V: lbf Units for M: lbf-ft

Y axis	DEAD	LIVE	LIVE ROOF	SNOW	WIND +	WIND -	SEISMIC +	SEISMIC -	ICE	RAIN	EARTH
A	148	340	0	0	0	0	0	0	0	0	0
B	148	340	0	0	0	0	0	0	0	0	0

Reaction Location

A

B

LOAD LIST

Type	Left Magnitude	Right Magnitude	Load Start (ft)	Load End (ft)	Load Type	Direction
Uniform (lbf/ft ²)	40	40	0	12.75	Live	Y
Uniform (lbf/ft ²)	15	15	0	12.75	Dead	Y
Self Weight (lbf/ft)	3.16	3.16	0	12.75	Dead	Y

DATE:	10/18/2021	COMPANY:	Pacific Northwest Structural Group, Inc
VITRUVIUS BUILD:	Base	DESIGNED BY:	David Starkel
CUSTOMER:		REVIEWED BY:	David Starkel
PROJ. ADDRESS:	-- --	PROJECT NAME:	21-028 Framing
LEVEL:	S2.2	LOADING:	ASD
MEMBER NAME:	FJ5-2.2	CODE:	2018 International Building Code
MEMBER TYPE:	FLOOR JOIST	NDS:	2018 NDS
MATERIAL:	Solid Sawn		
Douglas Fir-Larch	No. 2	(1) 1.5 X 11.25	16(in) O.C.
			DRY

FJ5-2.2 DIAGRAM



BEAM PROPERTIES

Start (ft): 0 End (ft): 13.75 Member Slope: 0/12 Actual Length (ft): 13.75 O.C. Spacing(in): 16

Area	Ix	Iy	BSW	Lams	G	Kcr
(in ²)	(in ⁴)	(in ⁴)	(lbf/ft)			Creep Factor
16.88	177.98	3.16	3.85	1	0.5	1

STRENGTH PROPERTIES

	Fb (psi)	Ft (psi)	Fv (psi)	Fc (psi)	Fc⊥ (psi)	E (psi) x10 ³	Emin (psi) x10 ³
Base Values	900	575	180	1350	625	1600	580
Adjusted Values	1035	575	180	1350	625	1600	580
C _M	1	1	1	1	1	1	1
C _T	1	1	1	1	1	1	1
C _i	1	1	1	1	1	1	1
C _F	1	1	1	1	1	1	1

Bending Adjustment Factors C_{fu} = 1 C_r = 1.15

BEAM DATA

Span	Length (ft)	Unbraced Length (ft)		Beam End				
		Top	Bottom	Elev. Diff (ft)	CL(Top)	CL(Bottom)	CL(Left)	CL(Right)
1	13.75	0	13.75	0	1.00	0.48	1.00	1.00

PASS-FAIL

	PASS/FAIL	MAGNITUDE	STRENGTH	LOCATION (ft)	LOAD COMBO	DURATION FACTOR CD
Shear Stress Y (psi)	PASS (75.5%)	44.1	180.0	0	D+L	1
Bending Stress Y (psi)	PASS (37.5%)	647.0	1035.0	6.88	D+L	1
Deflection (in)	PASS (67.1%)	0.151 (=L/1096)	0.458 (=L/360)	6.88	L	
Bearing Stress (psi)	PASS (84.9%)	94.5	625.0	0	D+L	1

REACTIONS

Units for V: lbf Units for M: lbf-ft

Y axis	DEAD	LIVE	LIVE ROOF	SNOW	WIND +	WIND -	SEISMIC +	SEISMIC -	ICE	RAIN	EARTH
A	130	367	0	0	0	0	0	0	0	0	0
B	130	367	0	0	0	0	0	0	0	0	0

Reaction Location

A

B

CONNECTORS		(All connectors are Simpson Strong-Tie connectors)*			Header	Joist Nails (in)	Nailer
Support A	Model	Type	Adequacy (%)	Fastening (in)		Thickness (in)	
Primary	LUS210	Hanger	62.83	(8) 0.148 x 3	(4) 0.148 x 3	N/A	
Support B							
Primary	LUS210	Hanger	41.92	(8) 0.148 x 3	(4) 0.148 x 3	N/A	

Hanger at support A has seat sloped 0 degrees, skewed 0 degrees.

Hanger at support B has seat sloped 0 degrees, skewed 0 degrees.

WSR = web stiffeners required

*Capacity values are adjusted based on specific gravity when members use grades other than those specified in Simpson Strong-Tie's capacity tables.



LOAD LIST							
Type	Left Magnitude	Right Magnitude	Load Start (ft)	Load End (ft)	Load Type	Direction	
Uniform (lbf/ft ²)	40	40	0	13.75	Live	Y	
Uniform (lbf/ft)	15	15	0	13.75	Dead	Y	
Self Weight (lbf/ft)	3.85	3.85	0	13.75	Dead	Y	

DATE:	10/18/2021	COMPANY:	Pacific Northwest Structural Group, Inc
VITRUVIUS BUILD:	Base	DESIGNED BY:	David Starkel
CUSTOMER:		REVIEWED BY:	David Starkel
PROJ. ADDRESS:	-- --	PROJECT NAME:	21-028 Framing
LEVEL:	S2.2	LOADING:	ASD
MEMBER NAME:	FJ2-2.2	CODE:	2018 International Building Code
MEMBER TYPE:	FLOOR JOIST	NDS:	2018 NDS
MATERIAL:	Solid Sawn		
Douglas Fir-Larch	No. 2	(1) 1.5 X 9.25	16(in) O.C.
			DRY

FJ2-2.2 DIAGRAM



BEAM PROPERTIES

Start (ft): 0 End (ft): 11.25 Member Slope: 0/12 Actual Length (ft): 11.25 O.C. Spacing(in): 16

Area	Ix	Iy	BSW	Lams	G	Kcr
(in ²)	(in ⁴)	(in ⁴)	(lbf/ft)			Creep Factor
13.88	98.93	2.6	3.16	1	0.5	1

STRENGTH PROPERTIES

	Fb (psi)	Ft (psi)	Fv (psi)	Fc (psi)	Fc⊥ (psi)	E (psi) x10 ³	Emin (psi) x10 ³
Base Values	900	575	180	1350	625	1600	580
Adjusted Values	1138	632	180	1350	625	1600	580
C _M	1	1	1	1	1	1	1
C _T	1	1	1	1	1	1	1
C _i	1	1	1	1	1	1	1
C _F	1.1	1.1	1	1	1	1	1

Bending Adjustment Factors C_{fu} = 1 C_r = 1.15

BEAM DATA

Span	Length (ft)	Unbraced Length (ft)		Beam End				
		Top	Bottom	Elev. Diff (ft)	CL(Top)	CL(Bottom)	CL(Left)	CL(Right)
1	11.25	0	11.25	0	1.00	0.63	1.00	1.00

PASS-FAIL

	PASS/FAIL	MAGNITUDE	STRENGTH	LOCATION (ft)	LOAD COMBO	DURATION FACTOR CD
Shear Stress Y (psi)	PASS (74.2%)	46.5	180.0	0	D+L	1
Bending Stress Y (psi)	PASS (40.4%)	678.9	1138.5	5.62	D+L	1
Deflection (in)	PASS (67.6%)	0.121 (=L/1112)	0.375 (=L/360)	5.62	L	
Bearing Stress (psi)	PASS (86.9%)	82.0	625.0	0	D+L	1

REACTIONS

Units for V: lbf Units for M: lbf-ft

Y axis	DEAD	LIVE	LIVE ROOF	SNOW	WIND +	WIND -	SEISMIC +	SEISMIC -	ICE	RAIN	EARTH
A	130	300	0	0	0	0	0	0	0	0	0
B	130	300	0	0	0	0	0	0	0	0	0

Reaction Location

A

B

LOAD LIST

Type	Left Magnitude	Right Magnitude	Load Start (ft)	Load End (ft)	Load Type	Direction
Uniform (lbf/ft ²)	40	40	0	11.25	Live	Y
Uniform (lbf/ft ²)	15	15	0	11.25	Dead	Y
Self Weight (lbf/ft)	3.16	3.16	0	11.25	Dead	Y

DATE:	10/18/2021	COMPANY:	Pacific Northwest Structural Group, Inc		
VITRUVIUS BUILD:	Base	DESIGNED BY:	David Starkel		
CUSTOMER:		REVIEWED BY:	David Starkel		
PROJ. ADDRESS:	--	PROJECT NAME:	21-028 Framing		
	--				
LEVEL:	S2.2	LOADING:	ASD		
MEMBER NAME:	FJ3-2.2	CODE:	2018 International Building Code		
MEMBER TYPE:	FLOOR JOIST	NDS:	2018 NDS		
MATERIAL:	Solid Sawn				
Douglas Fir-Larch	No. 1	(1) 1.5 X 9.25	16(in) O.C.	DRY	

FJ3-2.2 DIAGRAM



BEAM PROPERTIES

Start (ft): 0 End (ft): 14.667 Member Slope: 0/12 Actual Length (ft): 14.67 O.C. Spacing(in): 16

Area	I _x	I _y	BSW	Lams	G	K _{cr}
(in ²)	(in ⁴)	(in ⁴)	(lbf/ft)			Creep Factor
13.88	98.93	2.6	3.16	1	0.5	1

STRENGTH PROPERTIES

	F _b (psi)	F _t (psi)	F _v (psi)	F _c (psi)	F _{c⊥} (psi)	E (psi) x10 ³	E _{min} (psi) x10 ³
Base Values	1000	675	180	1500	625	1700	620
Adjusted Values	1265	742	180	1500	625	1700	620
C _M	1	1	1	1	1	1	1
C _T	1	1	1	1	1	1	1
C _i	1	1	1	1	1	1	1
C _F	1.1	1.1	1	1	1	1	1

Bending Adjustment Factors C_{fu} = 0.74C_r = 1.15

BEAM DATA

Span	Length (ft)	Unbraced Length (ft)		Beam End				
		Top	Bottom	Elev. Diff (ft)	CL(Top)	CL(Bottom)	CL(Left)	CL(Right)
1	14.6667	0	14.6667	0	1.00	0.48	1.00	1.00

PASS-FAIL

	PASS/FAIL	MAGNITUDE	STRENGTH	LOCATION (ft)	LOAD COMBO	DURATION FACTOR CD
Shear Stress Y (psi)	PASS (66.3%)	60.6	180.0	14.67	D+L	1
Bending Stress Y (psi)	PASS (8.8%)	1153.9	1265.0	7.33	D+L	1
Deflection (in)	PASS (32.5%)	0.330 (=L/533)	0.489 (=L/360)	7.33	L	
Bearing Stress (psi)	PASS (82.9%)	106.9	625.0	0	D+L	1

REACTIONS

Units for V: lbf Units for M: lbf-ft

Y axis	DEAD	LIVE	LIVE ROOF	SNOW	WIND +	WIND -	SEISMIC +	SEISMIC -	ICE	RAIN	EARTH
A	170	391	0	0	0	0	0	0	0	0	0
B	170	391	0	0	0	0	0	0	0	0	0

Reaction Location

A

B

CONNECTORS		(All connectors are Simpson Strong-Tie connectors)*			Header	Joist Nails (in)	Nailer
Support A	Model	Type	Adequacy (%)	Fastening (in)		Thickness (in)	
Primary	LUS210	Hanger	57.98	(8) 0.148 x 3	(4) 0.148 x 3	N/A	

Hanger at support A has seat sloped 0 degrees, skewed 0 degrees.

WSR = web stiffeners required

*Capacity values are adjusted based on specific gravity when members use grades other than those specified in Simpson Strong-Tie's capacity tables.



LOAD LIST						
Type	Left Magnitude	Right Magnitude	Load Start (ft)	Load End (ft)	Load Type	Direction
Uniform (lb/ft ²)	40	40	0	14.6667	Live	Y
Uniform (lb/ft ²)	15	15	0	14.6667	Dead	Y
Self Weight (lb/ft)	3.16	3.16	0	14.6667	Dead	Y

DATE:	10/18/2021	COMPANY:	Pacific Northwest Structural Group, Inc	
VITRUVIUS BUILD:	Base	DESIGNED BY:	David Starkel	
CUSTOMER:		REVIEWED BY:	David Starkel	
PROJ. ADDRESS:	-- --	PROJECT NAME:	21-028 Framing	
LEVEL:	S2.2	LOADING:	ASD	
MEMBER NAME:	FJ4-2.2	CODE:	2018 International Building Code	
MEMBER TYPE:	FLOOR JOIST	NDS:	2018 NDS	
MATERIAL:	Solid Sawn			
Douglas Fir-Larch	No. 2	(1) 1.5 X 9.25	16(in) O.C.	DRY

FJ4-2.2 DIAGRAM



BEAM PROPERTIES

Start (ft): 0 End (ft): 13.333 Member Slope: 0/12 Actual Length (ft): 13.33 O.C. Spacing(in): 16

Area	Ix	Iy	BSW	Lams	G	Kcr
(in ²)	(in ⁴)	(in ⁴)	(lbf/ft)			Creep Factor
13.88	98.93	2.6	3.16	1	0.5	1

STRENGTH PROPERTIES

	Fb (psi)	Ft (psi)	Fv (psi)	Fc (psi)	Fc⊥ (psi)	E (psi) x10 ³	Emin (psi) x10 ³
Base Values	900	575	180	1350	625	1600	580
Adjusted Values	1138	632	180	1350	625	1600	580
C _M	1	1	1	1	1	1	1
C _T	1	1	1	1	1	1	1
C _i	1	1	1	1	1	1	1
C _F	1.1	1.1	1	1	1	1	1

Bending Adjustment Factors C_{fu} = 1 C_r = 1.15

BEAM DATA

Span	Length (ft)	Unbraced Length (ft)		Beam End				
		Top	Bottom	Elev. Diff (ft)	CL(Top)	CL(Bottom)	CL(Left)	CL(Right)
1	13.3334	0	13.3334	0	1.00	0.54	1.00	1.00

PASS-FAIL

	PASS/FAIL	MAGNITUDE	STRENGTH	LOCATION (ft)	LOAD COMBO	DURATION FACTOR CD
Shear Stress Y (psi)	PASS (69.4%)	55.1	180.0	0	D+L	1
Bending Stress Y (psi)	PASS (16.2%)	953.7	1138.5	6.67	D+L	1
Deflection (in)	PASS (46.1%)	0.240 (=L/668)	0.444 (=L/360)	6.67	L	
Bearing Stress (psi)	PASS (84.5%)	97.1	625.0	0	D+L	1

REACTIONS

Units for V: lbf Units for M: lbf-ft

Y axis	DEAD	LIVE	LIVE ROOF	SNOW	WIND +	WIND -	SEISMIC +	SEISMIC -	ICE	RAIN	EARTH
A	154	356	0	0	0	0	0	0	0	0	0
B	154	356	0	0	0	0	0	0	0	0	0

Reaction Location

A

B

LOAD LIST

Type	Left Magnitude	Right Magnitude	Load Start (ft)	Load End (ft)	Load Type	Direction
Uniform (lbf/ft ²)	40	40	0	13.3334	Live	Y
Uniform (lbf/ft ²)	15	15	0	13.3334	Dead	Y
Self Weight (lbf/ft)	3.16	3.16	0	13.3334	Dead	Y

DATE:	10/18/2021	COMPANY:	Pacific Northwest Structural Group, Inc
VITRUVIUS BUILD:	Base	DESIGNED BY:	David Starkel
CUSTOMER:		REVIEWED BY:	David Starkel
PROJ. ADDRESS:	--	PROJECT NAME:	21-028 Framing
	--		
LEVEL:	S2.1	LOADING:	
MEMBER NAME:	FTG-FB5-2.2B	CODE:	2018 International Building Code
MEMBER TYPE:	ISOLATED FOOTING	ACI:	ACI 318-14
MATERIAL:	Concrete		
2 (ft) X 2 (ft) X 10 (in)		Soil Depth TOF: 0 (ft)	(3) #4 Long, (3) #4 Short

FTG-FB5-2.2B DIAGRAMS

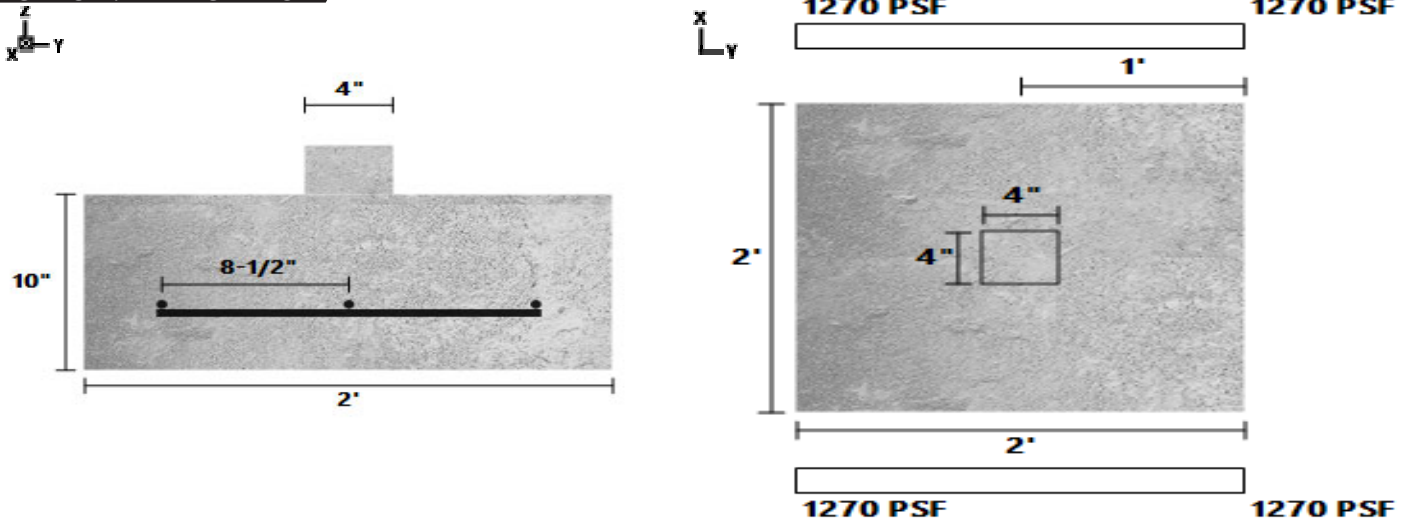

MATERIAL PROPERTIES

FOOTING						
fc' (psi)	Ec (psi)	Density (lb/ft ³)	Width (ft)	Length (ft)	Depth (in)	Volume (ft ³)
2500	2880952	145	2	2	10	3.33
CALCULATION VARIABLES						
Bo (in)	Φ-X	Φ-Y				
42	0	0				
COLUMN						
Width (in)	Length (in)	Material	Offset (in)			
4	4	Concrete	0			
SOIL						
Bearing Strength (lb/ft ²)	Density (lb/ft ³)	Cohesion	Friction Angle	Depth (ft)	Rankine Coefficient (Kp)	
1500	140	0	30	0	3	
REBAR						
Bar Size #	# Bars Long	# Bars Short	fy (psi)	Es (psi)		
4	3	3	60000	2.9E+07		

PASS-FAIL

	PASS/FAIL	MAGNITUDE	STRENGTH	LOAD COMBO
Soil Bearing Pressure (lb/ft ²)	PASS (15.4%)	1269.6	1500.0	D+Lr
Two-Way Shear (Punching) (lbf)	PASS (81.5%)	7557.1	40950.0	1.2D+1.6Lr+L
One-Way Shear X (lbf)	PASS (90.6%)	1102.1	11700.0	1.2D+1.6Lr+L
Moment X (lbf-ft)	PASS (59.0%)	1312.0	3200.0	1.2D+1.6Lr+L
One-Way Shear Y (lbf)	PASS (90.6%)	1102.1	11700.0	1.2D+1.6Lr+L
Moment Y (lbf-ft)	PASS (59.0%)	1312.0	3200.0	1.2D+1.6Lr+L
Crushing (psi)	PASS (65.8%)	472.3	1381.3	1.2D+1.6Lr+L

LOAD LIST

Type	Left Magnitude	Right Magnitude	Load Start (ft)	Load End (ft)	Load Type	Direction
------	----------------	-----------------	-----------------	---------------	-----------	-----------

LINKED LOAD LIST

Type	Left Magnitude	Right Magnitude	Load Start (ft)	Load End (ft)	Load Type	Direction
Point (lbf)	2341.958	-	0	-	Dead	Z
Point (lbf)	368.6582	-	0	-	Live	Z
Point (lbf)	1710.472	-	0	-	Snow	Z
Point (lbf)	2736.328	-	0	-	Roof Live	Z

DATE:	10/18/2021	COMPANY:	Pacific Northwest Structural Group, Inc
VITRUVIUS BUILD:	Base	DESIGNED BY:	David Starkel
CUSTOMER:		REVIEWED BY:	David Starkel
PROJ. ADDRESS:	--	PROJECT NAME:	21-028 Framing
	--		
LEVEL:	S2.1	LOADING:	
MEMBER NAME:	FTG-PST-DB2-2.2A	CODE:	2018 International Building Code
MEMBER TYPE:	ISOLATED FOOTING	ACI:	ACI 318-14
MATERIAL:	Concrete		
2.5 (ft) X 2.5 (ft) X 12 (in)		Soil Depth TOF: 0 (ft)	(4) #4 Long, (4) #4 Short

FTG-PST-DB2-2.2A DIAGRAMS

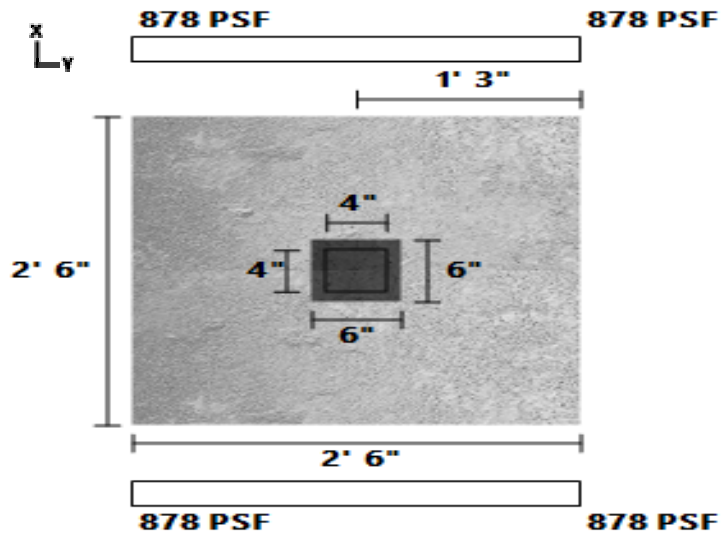
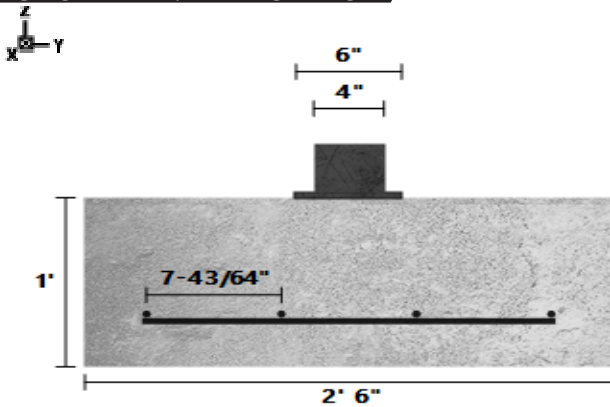

MATERIAL PROPERTIES

FOOTING						
fc' (psi)	Ec (psi)	Density (lb/ft ³)	Width (ft)	Length (ft)	Depth (in)	Volume (ft ³)
2500	2880952	145	2.5	2.5	12	6.25
CALCULATION VARIABLES						
Bo (in)	Φ-X	Φ-Y				
54	0	0				
COLUMN						
Width (in)	length (in)	Plate Width (in)	Plate Length (in)	Plate Thickness (in)	Material	Offset (in)
4	4	6	6	0	Steel	0
SOIL						
Bearing Strength (lb/ft ²)	Density (lb/ft ³)	Cohesion	Friction Angle	Depth (ft)	Rankine Coefficient (Kp)	
1500	140	0	30	0	3	
REBAR						
Bar Size #	# Bars Long	# Bars Short	fy (psi)	Es (psi)		
4	4	4	60000	2.9E+07		

PASS-FAIL

	PASS/FAIL	MAGNITUDE	STRENGTH	LOAD COMBO
Soil Bearing Pressure (lb/ft ²)	PASS (41.5%)	878.2	1500.0	D+L
Two-Way Shear (Punching) (lb)	PASS (88.0%)	8236.3	68850.0	1.2D+1.6L+0.5Lr
One-Way Shear X (lb)	PASS (94.3%)	1098.2	19125.0	1.2D+1.6L+0.5Lr
Moment X (lb-ft)	PASS (71.4%)	1787.4	6250.0	1.2D+1.6L+0.5Lr
One-Way Shear Y (lb)	PASS (94.3%)	1098.2	19125.0	1.2D+1.6L+0.5Lr
Moment Y (lb-ft)	PASS (71.4%)	1787.4	6250.0	1.2D+1.6L+0.5Lr
Crushing (psi)	PASS (83.4%)	228.8	1381.3	1.2D+1.6L+0.5Lr

LOAD LIST

Type	Left Magnitude	Right Magnitude	Load Start (ft)	Load End (ft)	Load Type	Direction
------	----------------	-----------------	-----------------	---------------	-----------	-----------

LINKED LOAD LIST

Type	Left Magnitude	Right Magnitude	Load Start (ft)	Load End (ft)	Load Type	Direction
Point (lbf)	1363.043	-	0	-	Dead	Z
Point (lbf)	4125.404	-	0	-	Live	Z

DATE:	10/18/2021	COMPANY:	Pacific Northwest Structural Group, Inc
VITRUVIUS BUILD:	Base	DESIGNED BY:	David Starkel
CUSTOMER:		REVIEWED BY:	David Starkel
PROJ. ADDRESS:	-- --	PROJECT NAME:	21-028 Framing
LEVEL:	S2.1	LOADING:	
MEMBER NAME:	FTG-PST-DB2-2.2B	CODE:	2018 International Building Code
MEMBER TYPE:	ISOLATED FOOTING	ACI:	ACI 318-14
MATERIAL:	Concrete		
3 (ft) X 3 (ft) X 12 (in)		Soil Depth TOF: 0 (ft)	(4) #4 Long, (4) #4 Short

FTG-PST-DB2-2.2B DIAGRAMS

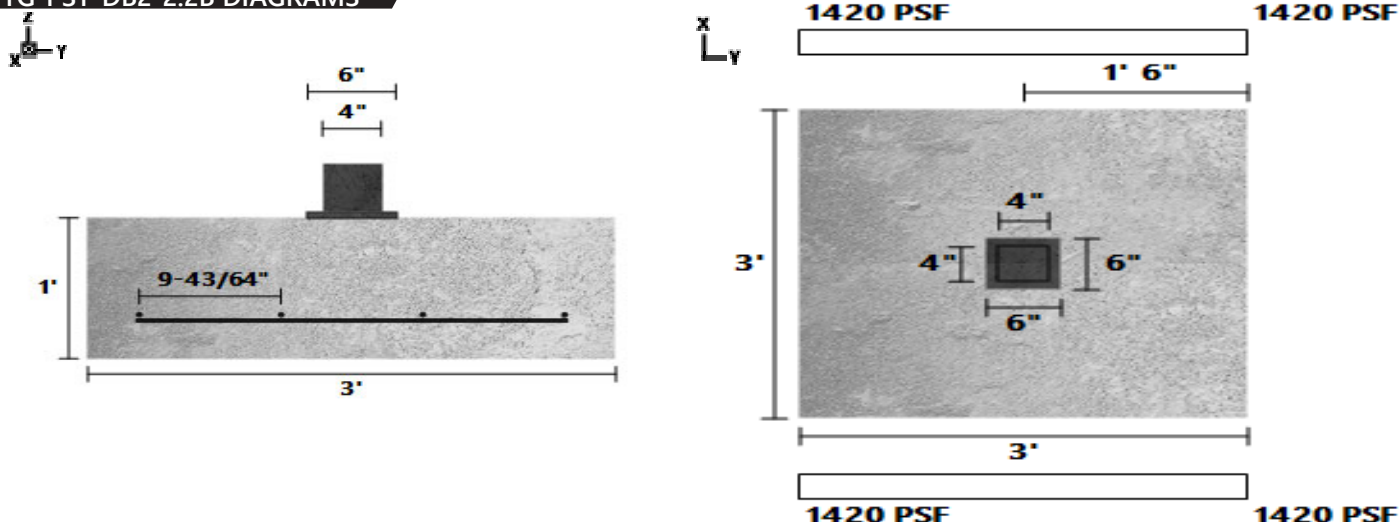

MATERIAL PROPERTIES

FOOTING						
fc' (psi)	Ec (psi)	Density (lb/ft ³)	Width (ft)	Length (ft)	Depth (in)	Volume (ft ³)
2500	2880952	145	3	3	12	9
CALCULATION VARIABLES						
Bo (in)	Φ-X	Φ-Y				
54	0	0				
COLUMN						
Width (in)	length (in)	Plate Width (in)	Plate Length (in)	Plate Thickness (in)	Material	Offset (in)
4	4	6	6	0	Steel	0
SOIL						
Bearing Strength (lb/ft ²)	Density (lb/ft ³)	Cohesion	Friction Angle	Depth (ft)	Rankine Coefficient (Kp)	
1500	140	0	30	0	3	
REBAR						
Bar Size #	# Bars Long	# Bars Short	fy (psi)	Es (psi)		
4	4	4	60000	2.9E+07		

PASS-FAIL

	PASS/FAIL	MAGNITUDE	STRENGTH	LOAD COMBO
Soil Bearing Pressure (lb/ft ²)	PASS (5.3%)	1420.1	1500.0	D+L
Two-Way Shear (Punching) (lbf)	PASS (72.1%)	1919.8	68850.0	1.2D+1.6L+0.5Lr
One-Way Shear X (lbf)	PASS (83.7%)	3731.7	22950.0	1.2D+1.6L+0.5Lr
Moment X (lbf-ft)	PASS (28.8%)	5336.6	7500.0	1.2D+1.6L+0.5Lr
One-Way Shear Y (lbf)	PASS (83.7%)	3731.7	22950.0	1.2D+1.6L+0.5Lr
Moment Y (lbf-ft)	PASS (28.8%)	5336.6	7500.0	1.2D+1.6L+0.5Lr
Crushing (psi)	PASS (61.4%)	533.1	1381.3	1.2D+1.6L+0.5Lr

LOAD LIST

Type	Left Magnitude	Right Magnitude	Load Start (ft)	Load End (ft)	Load Type	Direction
------	----------------	-----------------	-----------------	---------------	-----------	-----------

LINKED LOAD LIST

Type	Left Magnitude	Right Magnitude	Load Start (ft)	Load End (ft)	Load Type	Direction
Point (lbf)	3145.583	-	0	-	Dead	Z
Point (lbf)	9635.687	-	0	-	Live	Z

DATE:	10/18/2021	COMPANY:	Pacific Northwest Structural Group, Inc
VITRUVIUS BUILD:	Base	DESIGNED BY:	David Starkel
CUSTOMER:		REVIEWED BY:	David Starkel
PROJ. ADDRESS:	-- --	PROJECT NAME:	21-028 Framing
LEVEL:	S2.1	LOADING:	
MEMBER NAME:	FTG-PST-DB3-2.2A	CODE:	2018 International Building Code
MEMBER TYPE:	ISOLATED FOOTING	ACI:	ACI 318-14
MATERIAL:	Concrete		
2.5 (ft) X 2.5 (ft) X 12 (in)		Soil Depth TOF: 0 (ft)	(4) #4 Long, (4) #4 Short

FTG-PST-DB3-2.2A DIAGRAMS

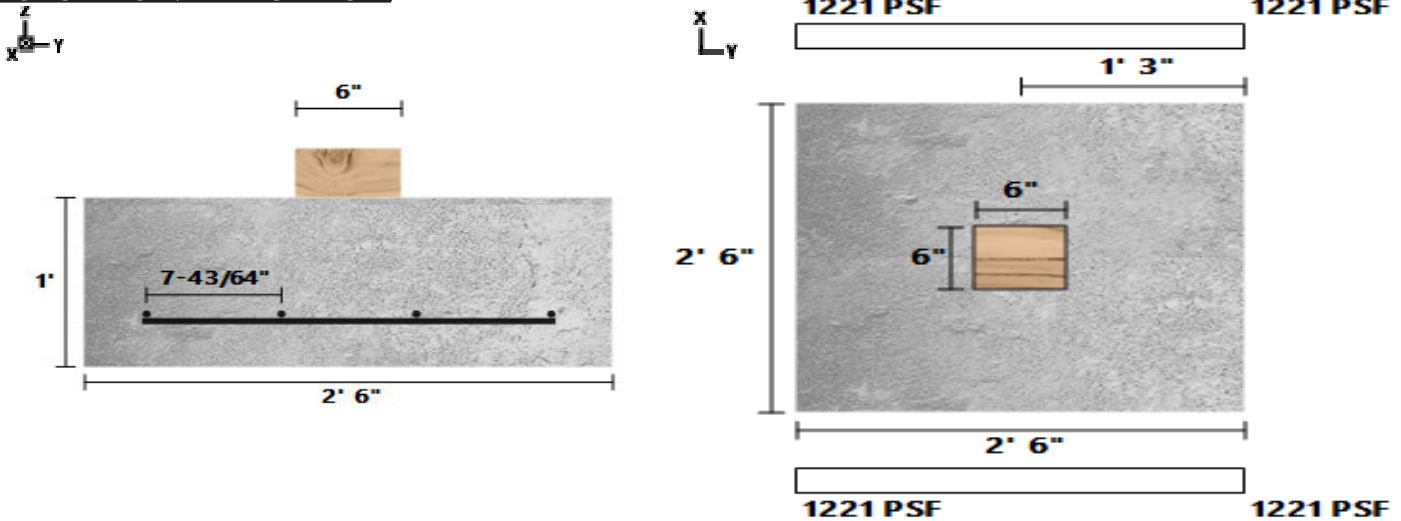

MATERIAL PROPERTIES

FOOTING						
fc' (psi)	Ec (psi)	Density (lb/ft ³)	Width (ft)	Length (ft)	Depth (in)	Volume (ft ³)
2500	2880952	145	2.5	2.5	12	6.25
CALCULATION VARIABLES						
Bo (in)	Φ-X	Φ-Y				
58	0	0				
COLUMN						
Width (in)	Length (in)	Material	Offset (in)			
6	6	Wood	0			
SOIL						
Bearing Strength (lb/ft ²)	Density (lb/ft ³)	Cohesion	Friction Angle	Depth (ft)	Rankine Coefficient (Kp)	
1500	140	0	30	0	3	
REBAR						
Bar Size #	# Bars Long	# Bars Short	fy (psi)	Es (psi)		
4	4	4	60000	2.9E+07		

PASS-FAIL

	PASS/FAIL	MAGNITUDE	STRENGTH	LOAD COMBO
Soil Bearing Pressure (lb/ft ²)	PASS (18.6%)	1220.8	1500.0	D+0.75L+0.75S
Two-Way Shear (Punching) (lbf)	PASS (85.5%)	10749.9	73950.0	1.2D+1.6S+L
One-Way Shear X (lbf)	PASS (93.4%)	1254.2	19125.0	1.2D+1.6S+L
Moment X (lbf-ft)	PASS (65.6%)	2150.0	6250.0	1.2D+1.6S+L
One-Way Shear Y (lbf)	PASS (93.4%)	1254.2	19125.0	1.2D+1.6S+L
Moment Y (lbf-ft)	PASS (65.6%)	2150.0	6250.0	1.2D+1.6S+L
Crushing (psi)	PASS (78.4%)	298.6	1381.3	1.2D+1.6S+L

LOAD LIST

Type	Left Magnitude	Right Magnitude	Load Start (ft)	Load End (ft)	Load Type	Direction
------	----------------	-----------------	-----------------	---------------	-----------	-----------

LINKED LOAD LIST

Type	Left Magnitude	Right Magnitude	Load Start (ft)	Load End (ft)	Load Type	Direction
Point (lbf)	3827.668	-	0	-	Dead	Z
Point (lbf)	3258.915	-	0	-	Live	Z
Point (lbf)	1811.1	-	0	-	Snow	Z
Point (lbf)	1448.941	-	0	-	Roof Live	Z

DATE:	10/18/2021	COMPANY:	Pacific Northwest Structural Group, Inc
VITRUVIUS BUILD:	Base	DESIGNED BY:	David Starkel
CUSTOMER:		REVIEWED BY:	David Starkel
PROJ. ADDRESS:	-- --	PROJECT NAME:	21-028 Framing
LEVEL:	S2.1	LOADING:	
MEMBER NAME:	FTG-PST-FB3-2.2B	CODE:	2018 International Building Code
MEMBER TYPE:	ISOLATED FOOTING	ACI:	ACI 318-14
MATERIAL:	Concrete		
3 (ft) X 3 (ft) X 12 (in)		Soil Depth TOF: 0 (ft)	(4) #4 Long, (4) #4 Short

FTG-PST-FB3-2.2B DIAGRAMS

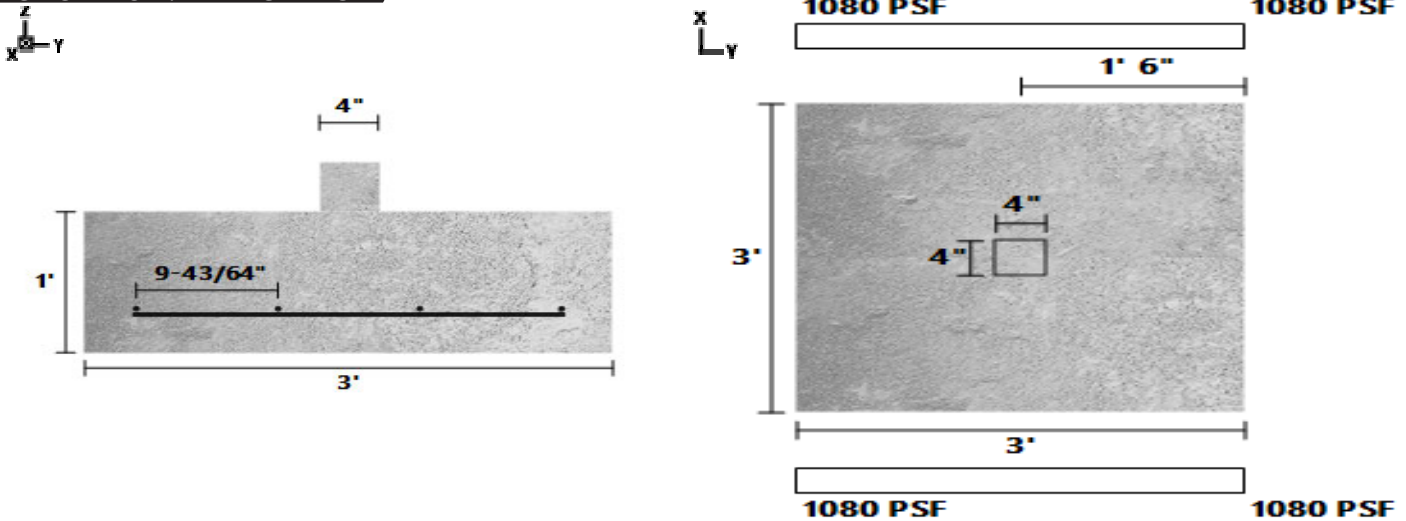

MATERIAL PROPERTIES

FOOTING						
fc' (psi)	Ec (psi)	Density (lb/ft ³)	Width (ft)	Length (ft)	Depth (in)	Volume (ft ³)
2500	2880952	145	3	3	12	9
CALCULATION VARIABLES						
Bo (in)	Φ-X	Φ-Y				
50	0	0				
COLUMN						
Width (in)	Length (in)	Material	Offset (in)			
4	4	Concrete	0			
SOIL						
Bearing Strength (lb/ft ²)	Density (lb/ft ³)	Cohesion	Friction Angle	Depth (ft)	Rankine Coefficient (Kp)	
1500	140	0	30	0	3	
REBAR						
Bar Size #	# Bars Long	# Bars Short	fy (psi)	Es (psi)		
4	4	4	60000	2.9E+07		

PASS-FAIL

	PASS/FAIL	MAGNITUDE	STRENGTH	LOAD COMBO
Soil Bearing Pressure (lb/ft ²)	PASS (28.0%)	1079.7	1500.0	D+0.75L+0.75S
Two-Way Shear (Punching) (lb)	PASS (77.1%)	14628.0	63750.0	1.2D+1.6S+L
One-Way Shear X (lb)	PASS (86.7%)	3047.5	22950.0	1.2D+1.6S+L
Moment X (lb-ft)	PASS (42.2%)	4334.2	7500.0	1.2D+1.6S+L
One-Way Shear Y (lb)	PASS (86.7%)	3047.5	22950.0	1.2D+1.6S+L
Moment Y (lb-ft)	PASS (42.2%)	4334.2	7500.0	1.2D+1.6S+L
Crushing (psi)	PASS (33.8%)	914.2	1381.3	1.2D+1.6S+L

LOAD LIST

Type	Left Magnitude	Right Magnitude	Load Start (ft)	Load End (ft)	Load Type	Direction
------	----------------	-----------------	-----------------	---------------	-----------	-----------

LINKED LOAD LIST

Type	Left Magnitude	Right Magnitude	Load Start (ft)	Load End (ft)	Load Type	Direction
Point (lbf)	4746.396	-	0	-	Dead	Z
Point (lbf)	2786.667	-	0	-	Live	Z
Point (lbf)	3841.006	-	0	-	Snow	Z
Point (lbf)	3072.984	-	0	-	Roof Live	Z

DATE:	10/18/2021	COMPANY:	Pacific Northwest Structural Group, Inc
VITRUVIUS BUILD:	Base	DESIGNED BY:	David Starkel
CUSTOMER:		REVIEWED BY:	David Starkel
PROJ. ADDRESS:	-- --	PROJECT NAME:	21-028 Framing
LEVEL:	S2.1	LOADING:	
MEMBER NAME:	FTG-PST-FB6-2.2A	CODE:	2018 International Building Code
MEMBER TYPE:	ISOLATED FOOTING	ACI:	ACI 318-14
MATERIAL:	Concrete		
2 (ft) X 2 (ft) X 10 (in)		Soil Depth TOF: 0 (ft)	(3) #4 Long, (3) #4 Short

FTG-PST-FB6-2.2A DIAGRAMS

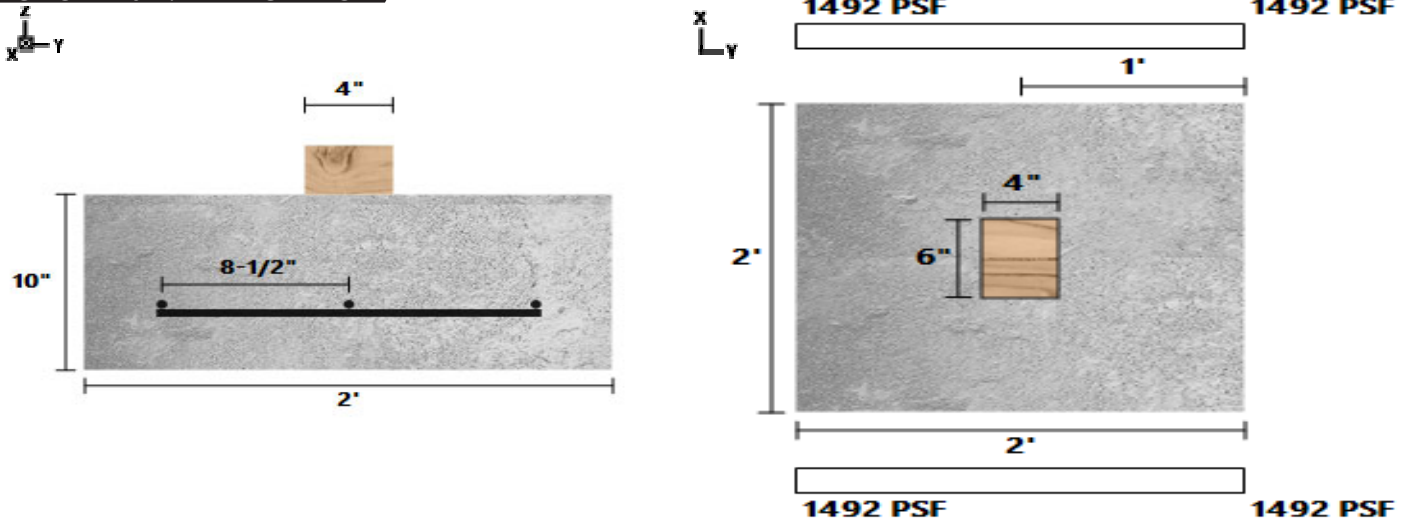

MATERIAL PROPERTIES

FOOTING						
fc' (psi)	Ec (psi)	Density (lb/ft ³)	Width (ft)	Length (ft)	Depth (in)	Volume (ft ³)
2500	2880952	145	2	2	10	3.33
CALCULATION VARIABLES						
Bo (in)	Φ-X	Φ-Y				
46	0	0				
COLUMN						
Width (in)	Length (in)	Material	Offset (in)			
4	6	Wood	0			
SOIL						
Bearing Strength (lb/ft ²)	Density (lb/ft ³)	Cohesion	Friction Angle	Depth (ft)	Rankine Coefficient (Kp)	
1500	140	0	30	0	3	
REBAR						
Bar Size #	# Bars Long	# Bars Short	fy (psi)	Es (psi)		
4	3	3	60000	2.9E+07		

PASS-FAIL

	PASS/FAIL	MAGNITUDE	STRENGTH	LOAD COMBO
Soil Bearing Pressure (lb/ft ²)	PASS (0.5%)	1492.2	1500.0	D+0.75L+0.75S
Two-Way Shear (Punching) (lbf)	PASS (79.9%)	9028.1	44850.0	1.2D+1.6S+L
One-Way Shear X (lbf)	PASS (92.0%)	940.4	11700.0	1.2D+1.6S+L
Moment X (lbf-ft)	PASS (60.3%)	1269.6	3200.0	1.2D+1.6S+L
One-Way Shear Y (lbf)	PASS (88.7%)	1316.6	11700.0	1.2D+1.6S+L
Moment Y (lbf-ft)	PASS (51.0%)	1567.4	3200.0	1.2D+1.6S+L
Crushing (psi)	PASS (72.8%)	376.2	1381.3	1.2D+1.6S+L

LOAD LIST

Type	Left Magnitude	Right Magnitude	Load Start (ft)	Load End (ft)	Load Type	Direction
------	----------------	-----------------	-----------------	---------------	-----------	-----------

LINKED LOAD LIST

Type	Left Magnitude	Right Magnitude	Load Start (ft)	Load End (ft)	Load Type	Direction
Point (lbf)	2398.703	-	0	-	Dead	Z
Point (lbf)	2315.983	-	0	-	Snow	Z
Point (lbf)	-217.7031	-	0	-	Live	Z
Point (lbf)	-107.4312	-	0	-	Roof Live	Z
Point (lbf)	2444.114	-	0	-	Live	Z
Point (lbf)	1967.185	-	0	-	Roof Live	Z

DATE:	10/18/2021	COMPANY:	Pacific Northwest Structural Group, Inc
VITRUVIUS BUILD:	Base	DESIGNED BY:	David Starkel
CUSTOMER:		REVIEWED BY:	David Starkel
PROJ. ADDRESS:	-- --	PROJECT NAME:	21-028 Framing
LEVEL:	S2.1	LOADING:	
MEMBER NAME:	FTG-PST-FB6-2.2B	CODE:	2018 International Building Code
MEMBER TYPE:	ISOLATED FOOTING	ACI:	ACI 318-14
MATERIAL:	Concrete		
3.5 (ft) X 3.5 (ft) X 12 (in)		Soil Depth TOF: 0 (ft)	(5) #4 Long, (5) #4 Short

FTG-PST-FB6-2.2B DIAGRAMS

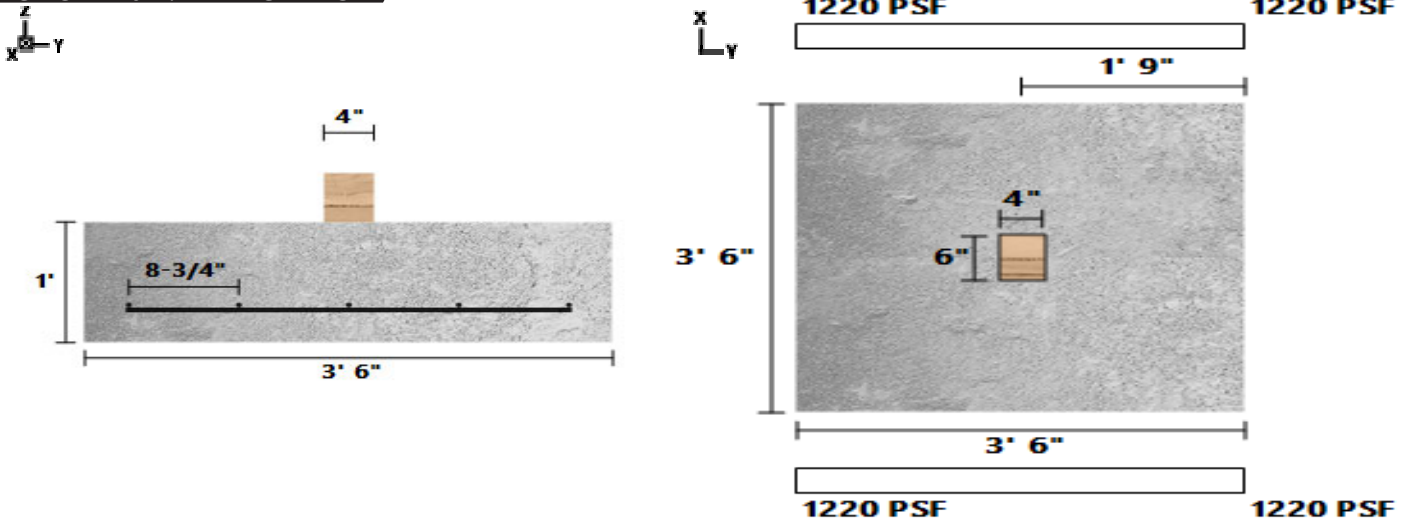

MATERIAL PROPERTIES

FOOTING						
fc' (psi)	Ec (psi)	Density (lb/ft ³)	Width (ft)	Length (ft)	Depth (in)	Volume (ft ³)
2500	2880952	145	3.5	3.5	12	12.25
CALCULATION VARIABLES						
Bo (in)	Φ-X	Φ-Y				
54	0	0				
COLUMN						
Width (in)	Length (in)	Material	Offset (in)			
4	6	Wood	0			
SOIL						
Bearing Strength (lb/ft ²)	Density (lb/ft ³)	Cohesion	Friction Angle	Depth (ft)	Rankine Coefficient (Kp)	
1500	140	0	30	0	3	
REBAR						
Bar Size #	# Bars Long	# Bars Short	fy (psi)	Es (psi)		
4	5	5	60000	2.9E+07		

PASS-FAIL

	PASS/FAIL	MAGNITUDE	STRENGTH	LOAD COMBO
Soil Bearing Pressure (lb/ft ²)	PASS (18.7%)	1219.4	1500.0	D+0.75L+0.75S
Two-Way Shear (Punching) (lb)	PASS (67.3%)	22527.4	68850.0	1.2D+1.6S+L
One-Way Shear X (lb)	PASS (81.0%)	5095.5	26775.0	1.2D+1.6S+L
Moment X (lb-ft)	PASS (80.3%)	7240.9	36737.4	1.2D+1.6S+L
One-Way Shear Y (lb)	PASS (79.0%)	5631.8	26775.0	1.2D+1.6S+L
Moment Y (lb-ft)	PASS (78.0%)	8067.8	36737.4	1.2D+1.6S+L
Crushing (psi)	PASS (32.0%)	938.6	1381.3	1.2D+1.6S+L

LOAD LIST

Type	Left Magnitude	Right Magnitude	Load Start (ft)	Load End (ft)	Load Type	Direction
------	----------------	-----------------	-----------------	---------------	-----------	-----------

LINKED LOAD LIST

Type	Left Magnitude	Right Magnitude	Load Start (ft)	Load End (ft)	Load Type	Direction
Point (lbf)	6179.9	-	0	-	Dead	Z
Point (lbf)	5954.472	-	0	-	Live	Z
Point (lbf)	5723.145	-	0	-	Snow	Z
Point (lbf)	-92.39405	-	0	-	Roof Live	Z
Point (lbf)	4818.333	-	0	-	Roof Live	Z

DATE:	10/18/2021	COMPANY:	Pacific Northwest Structural Group, Inc
VITRUVIUS BUILD:	Base	DESIGNED BY:	David Starkel
CUSTOMER:		REVIEWED BY:	David Starkel
PROJ. ADDRESS:	-- --	PROJECT NAME:	21-028 Framing
LEVEL:	S2.1	LOADING:	
MEMBER NAME:	FTG-PST-FB6-2.2C-FB5-2.2A	CODE:	2018 International Building Code
MEMBER TYPE:	ISOLATED FOOTING	ACI:	ACI 318-14
MATERIAL:	Concrete		
2.5 (ft) X 2.5 (ft) X 12 (in)		Soil Depth TOF: 0 (ft)	(4) #4 Long, (4) #4 Short

FTG-PST-FB6-2.2C-FB5-2.2A DIAGRAMS

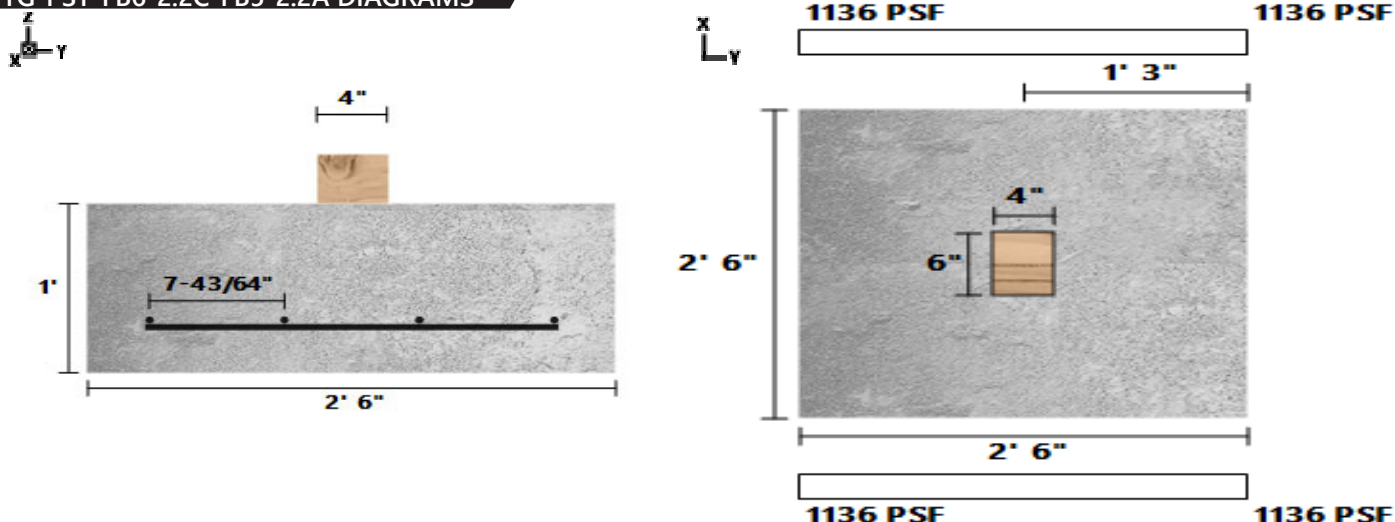

MATERIAL PROPERTIES

FOOTING						
fc' (psi)	Ec (psi)	Density (lb/ft ³)	Width (ft)	Length (ft)	Depth (in)	Volume (ft ³)
2500	2880952	145	2.5	2.5	12	6.25
CALCULATION VARIABLES						
Bo (in)	Φ-X	Φ-Y				
54	0	0				
COLUMN						
Width (in)	Length (in)	Material	Offset (in)			
4	6	Wood	0			
SOIL						
Bearing Strength (lb/ft ²)	Density (lb/ft ³)	Cohesion	Friction Angle	Depth (ft)	Rankine Coefficient (Kp)	
1500	140	0	30	0	3	
REBAR						
Bar Size #	# Bars Long	# Bars Short	fy (psi)	Es (psi)		
4	4	4	60000	2.9E+07		

PASS-FAIL

	PASS/FAIL	MAGNITUDE	STRENGTH	LOAD COMBO
Soil Bearing Pressure (lb/ft ²)	PASS (24.2%)	1136.4	1500.0	D+0.75L+0.75Lr
Two-Way Shear (Punching) (lb)	PASS (84.0%)	11033.1	68850.0	1.2D+1.6Lr+L
One-Way Shear X (lb)	PASS (93.3%)	1287.2	19125.0	1.2D+1.6Lr+L
Moment X (lb-ft)	PASS (64.7%)	2206.6	6250.0	1.2D+1.6Lr+L
One-Way Shear Y (lb)	PASS (91.3%)	1655.0	19125.0	1.2D+1.6Lr+L
Moment Y (lb-ft)	PASS (58.6%)	2589.7	6250.0	1.2D+1.6Lr+L
Crushing (psi)	PASS (66.7%)	459.7	1381.3	1.2D+1.6Lr+L

LOAD LIST

Type	Left Magnitude	Right Magnitude	Load Start (ft)	Load End (ft)	Load Type	Direction
------	----------------	-----------------	-----------------	---------------	-----------	-----------

LINKED LOAD LIST

Type	Left Magnitude	Right Magnitude	Load Start (ft)	Load End (ft)	Load Type	Direction
Point (lbf)	3078.514	-	0	-	Dead	Z
Point (lbf)	2212.221	-	0	-	Snow	Z
Point (lbf)	-390.5283	-	0	-	Live	Z
Point (lbf)	-283.1348	-	0	-	Roof Live	Z
Point (lbf)	2075.743	-	0	-	Live	Z
Point (lbf)	3289.445	-	0	-	Roof Live	Z

DATE:	10/18/2021	COMPANY:	Pacific Northwest Structural Group, Inc
VITRUVIUS BUILD:	Base	DESIGNED BY:	David Starkel
CUSTOMER:		REVIEWED BY:	David Starkel
PROJ. ADDRESS:	-- --	PROJECT NAME:	21-028 Framing
LEVEL:	S2.1	LOADING:	
MEMBER NAME:	FTG-PST-FB7-2.2B	CODE:	2018 International Building Code
MEMBER TYPE:	ISOLATED FOOTING	ACI:	ACI 318-14
MATERIAL:	Concrete		
2 (ft) X 2 (ft) X 10 (in)		Soil Depth TOF: 0 (ft)	(3) #4 Long, (3) #4 Short

FTG-PST-FB7-2.2B DIAGRAMS

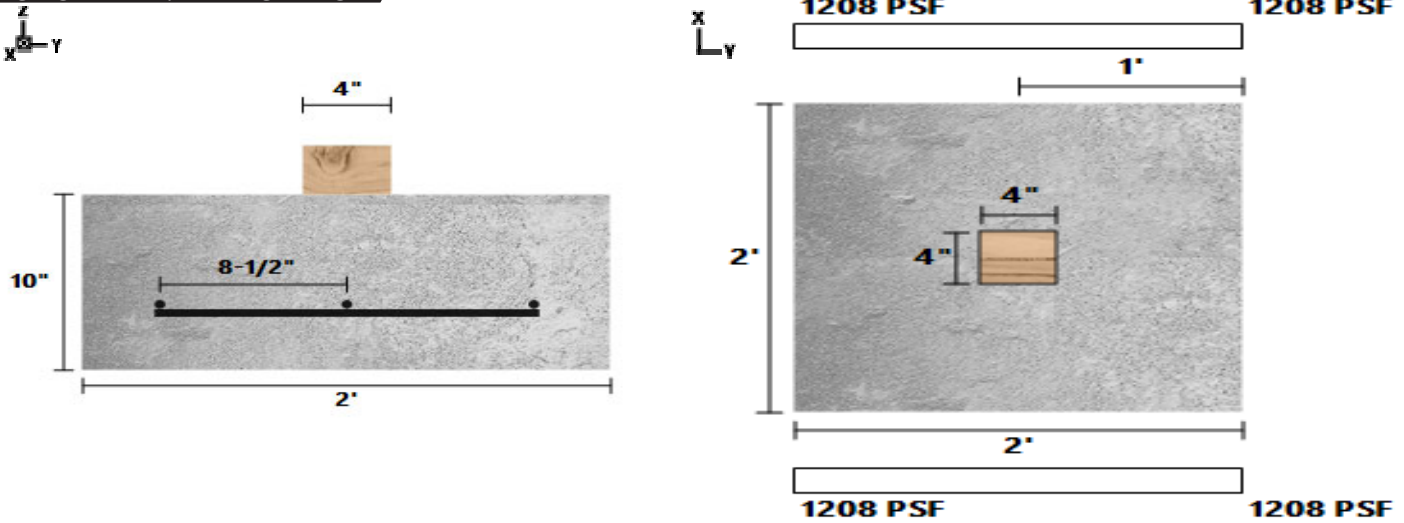

MATERIAL PROPERTIES

FOOTING						
fc' (psi)	Ec (psi)	Density (lb/ft ³)	Width (ft)	Length (ft)	Depth (in)	Volume (ft ³)
2500	2880952	145	2	2	10	3.33
CALCULATION VARIABLES						
Bo (in)	Φ-X	Φ-Y				
42	0	0				
COLUMN						
Width (in)	Length (in)	Material	Offset (in)			
4	4	Wood	0			
SOIL						
Bearing Strength (lb/ft ²)	Density (lb/ft ³)	Cohesion	Friction Angle	Depth (ft)	Rankine Coefficient (Kp)	
1500	140	0	30	0	3	
REBAR						
Bar Size #	# Bars Long	# Bars Short	fy (psi)	Es (psi)		
4	3	3	60000	2.9E+07		

PASS-FAIL

	PASS/FAIL	MAGNITUDE	STRENGTH	LOAD COMBO
Soil Bearing Pressure (lb/ft ²)	PASS (19.5%)	1208.0	1500.0	D+L
Two-Way Shear (Punching) (lbf)	PASS (82.8%)	7037.2	40950.0	1.2D+1.6L+0.5S
One-Way Shear X (lbf)	PASS (91.2%)	1026.3	11700.0	1.2D+1.6L+0.5S
Moment X (lbf-ft)	PASS (61.8%)	1221.7	3200.0	1.2D+1.6L+0.5S
One-Way Shear Y (lbf)	PASS (91.2%)	1026.3	11700.0	1.2D+1.6L+0.5S
Moment Y (lbf-ft)	PASS (61.8%)	1221.7	3200.0	1.2D+1.6L+0.5S
Crushing (psi)	PASS (68.2%)	439.8	1381.3	1.2D+1.6L+0.5S

LOAD LIST

Type	Left Magnitude	Right Magnitude	Load Start (ft)	Load End (ft)	Load Type	Direction
------	----------------	-----------------	-----------------	---------------	-----------	-----------

LINKED LOAD LIST

Type	Left Magnitude	Right Magnitude	Load Start (ft)	Load End (ft)	Load Type	Direction
Point (lbf)	2595.245	-	0	-	Dead	Z
Point (lbf)	2236.799	-	0	-	Live	Z
Point (lbf)	688.0073	-	0	-	Snow	Z

DATE:	10/18/2021	COMPANY:	Pacific Northwest Structural Group, Inc
VITRUVIUS BUILD:	Base	DESIGNED BY:	David Starkel
CUSTOMER:		REVIEWED BY:	David Starkel
PROJ. ADDRESS:	-- --	PROJECT NAME:	21-028 Framing
LEVEL:	S2.1	LOADING:	
MEMBER NAME:	FTG-PST-FB9-2.2A	CODE:	2018 International Building Code
MEMBER TYPE:	ISOLATED FOOTING	ACI:	ACI 318-14
MATERIAL:	Concrete		
3 (ft) X 3 (ft) X 12 (in)		Soil Depth TOF: 0 (ft)	(4) #4 Long, (4) #4 Short

FTG-PST-FB9-2.2A DIAGRAMS

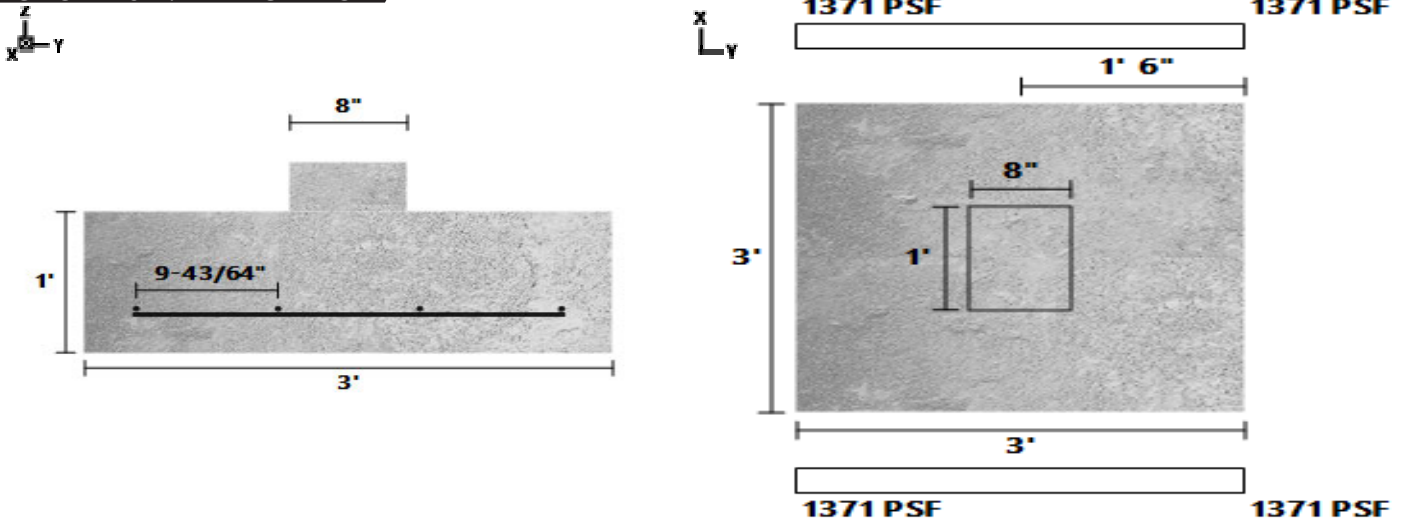

MATERIAL PROPERTIES

FOOTING						
fc' (psi)	Ec (psi)	Density (lb/ft ³)	Width (ft)	Length (ft)	Depth (in)	Volume (ft ³)
2500	2880952	145	3	3	12	9
CALCULATION VARIABLES						
Bo (in)	Φ-X	Φ-Y				
74	0	0				
COLUMN						
Width (in)	Length (in)	Material	Offset (in)			
8	12	Concrete	0			
SOIL						
Bearing Strength (lb/ft ²)	Density (lb/ft ³)	Cohesion	Friction Angle	Depth (ft)	Rankine Coefficient (Kp)	
1500	140	0	30	0	3	
REBAR						
Bar Size #	# Bars Long	# Bars Short	fy (psi)	Es (psi)		
4	4	4	60000	2.9E+07		

PASS-FAIL

	PASS/FAIL	MAGNITUDE	STRENGTH	LOAD COMBO
Soil Bearing Pressure (lb/ft ²)	PASS (8.6%)	1371.3	1500.0	D+0.75L+0.75S
Two-Way Shear (Punching) (lb)	PASS (81.3%)	17673.7	94350.0	1.2D+1.6S+L
One-Way Shear X (lb)	PASS (92.5%)	1718.3	22950.0	1.2D+1.6S+L
Moment X (lb-ft)	PASS (60.7%)	2945.6	7500.0	1.2D+1.6S+L
One-Way Shear Y (lb)	PASS (88.2%)	2700.1	22950.0	1.2D+1.6S+L
Moment Y (lb-ft)	PASS (46.5%)	4009.3	7500.0	1.2D+1.6S+L
Crushing (psi)	PASS (86.7%)	184.1	1381.3	1.2D+1.6S+L

LOAD LIST

Type	Left Magnitude	Right Magnitude	Load Start (ft)	Load End (ft)	Load Type	Direction
------	----------------	-----------------	-----------------	---------------	-----------	-----------

LINKED LOAD LIST

Type	Left Magnitude	Right Magnitude	Load Start (ft)	Load End (ft)	Load Type	Direction
Point (lbf)	5461.85	-	0	-	Dead	Z
Point (lbf)	5927.698	-	0	-	Live	Z
Point (lbf)	3244.844	-	0	-	Snow	Z
Point (lbf)	2595.984	-	0	-	Roof Live	Z

DATE:	10/18/2021	COMPANY:	Pacific Northwest Structural Group, Inc
VITRUVIUS BUILD:	Base	DESIGNED BY:	David Starkel
CUSTOMER:		REVIEWED BY:	David Starkel
PROJ. ADDRESS:	-- --	PROJECT NAME:	21-028 Framing
LEVEL:	S2.2	LOADING:	ASD
MEMBER NAME:	PST-DB2-2.2A	CODE:	2018 International Building Code
MEMBER TYPE:	COLUMN	NDS:	2018 NDS
MATERIAL:	Solid Sawn		
Hem-Fir	No. 2	(1) 7.5 X 7.5	DRY

PST-DB2-2.2A DIAGRAM



COLUMN PROPERTIES

Start(ft) 0	End(ft) 9						
Area	Ix	Iy	BSW	Lams	G	Kcr	
(in ²)	(in ⁴)	(in ⁴)	(lbf/ft)			Creep Factor	
56.25	263.67	263.67	11.1	1	0.43	1	

STRENGTH PROPERTIES

	Fb (psi)	Ft (psi)	Fv (psi)	Fc (psi)	Fc⊥ (psi)	E (psi) x10 ³	Emin (psi) x10 ³
Base Values	575	375	140	575	405	1100	400
Adjusted Values	575	375	140	575	405	1100	400
C _M	1	1	1	1	1	1	1
C _T	1	1	1	1	1	1	1
C _i	1	1	1	1	1	1	1
C _F	1	1	1	1	1	1	1

Bending Adjustment Factors C_{fu} = 1 C_r = 1

COLUMN DATA

Span	Length (ft)	Unbraced Length (ft)		Column End		Ke(X Axis)	Ke(Y Axis)	KeL/d (X Axis)	KeL/d (Y Axis)
		X	Y	Offset	CP				
1	9	9	9	0	0.91	1.00	1.00	14.4	14.4

PASS-FAIL

	PASS/FAIL	MAGNITUDE	STRENGTH	LOCATION (ft)	LOAD COMBO	DURATION FACTOR	CD
Deflection (in)	PASS (97.6%)	0.007 (=L/15000)	0.300 (=L/360)	9	L		
Compressive Stress (psi)	PASS (81.4%)	97.6	523.4	0	D+L		1

REACTIONS

Units for V: lbf Units for M: lbf-ft

Z axis	DEAD	LIVE	LIVE ROOF	SNOW	WIND +	WIND -	SEISMIC +	SEISMIC -	ICE	RAIN	EARTH
A	1363	4125	0	0	0	0	0	0	0	0	0
B	0	0	0	0	0	0	0	0	0	0	0

Reaction Location

A

B

LOAD LIST

Type	Left Magnitude	Right Magnitude	Load Start (ft)	Load End (ft)	Load Type	Direction
Self Weight (lbf/ft)	11.1	11.1	0	9	Dead	Z

LINKED LOAD LIST

Type	Left Magnitude	Right Magnitude	Load Start (ft)	Load End (ft)	Load Type	Direction
Point (lbf)	-1263.145	-	9	-	Dead	Z
Point (lbf)	-4125.404	-	9	-	Live	Z

DATE:	10/18/2021	COMPANY:	Pacific Northwest Structural Group, Inc
VITRUVIUS BUILD:	Base	DESIGNED BY:	David Starkel
CUSTOMER:		REVIEWED BY:	David Starkel
PROJ. ADDRESS:	-- --	PROJECT NAME:	21-028 Framing
LEVEL:	S2.2	LOADING:	ASD
MEMBER NAME:	PST-DB2-2.2B	CODE:	2018 International Building Code
MEMBER TYPE:	COLUMN	NDS:	2018 NDS
MATERIAL:	Solid Sawn		
Hem-Fir	No. 2	(1) 7.5 X 7.5	DRY
			INCISED

PST-DB2-2.2B DIAGRAM



COLUMN PROPERTIES

Start(ft) 0	End(ft) 9						
Area	Ix	Iy	BSW	Lams	G	Kcr	
(in ²)	(in ⁴)	(in ⁴)	(lbf/ft)			Creep Factor	
56.25	263.67	263.67	11.1	1	0.43	1	

STRENGTH PROPERTIES

	Fb (psi)	Ft (psi)	Fv (psi)	Fc (psi)	Fc⊥ (psi)	E (psi) x10 ³	Emin (psi) x10 ³
Base Values	575	375	140	575	405	1100	400
Adjusted Values	460	300	112	460	405	1045	380
C _M	1	1	1	1	1	1	1
C _T	1	1	1	1	1	1	1
C _i	0.8	0.8	0.8	0.8	1	0.95	0.95
C _F	1	1	1	1	1	1	1

Bending Adjustment Factors C_{fu} = 1 C_r = 1

COLUMN DATA

Span	Length (ft)	Unbraced Length (ft)		Column End					
		X	Y	Offset	CP	Ke(X Axis)	Ke(Y Axis)	KeL/d (X Axis)	KeL/d (Y Axis)
1	9	9	9	0	0.93	1.00	1.00	14.4	14.4

PASS-FAIL

	PASS/FAIL	MAGNITUDE	STRENGTH	LOCATION (ft)	LOAD COMBO	DURATION FACTOR	CD
Deflection (in)	PASS (94.1%)	0.018 (=L/6102)	0.300 (=L/360)	9	L		
Compressive Stress (psi)	PASS (46.7%)	227.2	426.3	0	D+L		1

REACTIONS

Units for V: lbf Units for M: lbf-ft

Z axis	DEAD	LIVE	LIVE ROOF	SNOW	WIND +	WIND -	SEISMIC +	SEISMIC -	ICE	RAIN	EARTH
A	3146	9636	0	0	0	0	0	0	0	0	0
B	0	0	0	0	0	0	0	0	0	0	0

Reaction Location

A

B

LOAD LIST

Type	Left Magnitude	Right Magnitude	Load Start (ft)	Load End (ft)	Load Type	Direction
Self Weight (lbf/ft)	11.1	11.1	0	9	Dead	Z

LINKED LOAD LIST

Type	Left Magnitude	Right Magnitude	Load Start (ft)	Load End (ft)	Load Type	Direction
Point (lbf)	-3045.685	-	9	-	Dead	Z
Point (lbf)	-9635.687	-	9	-	Live	Z

DATE:	10/18/2021	COMPANY:	Pacific Northwest Structural Group, Inc
VITRUVIUS BUILD:	Base	DESIGNED BY:	David Starkel
CUSTOMER:		REVIEWED BY:	David Starkel
PROJ. ADDRESS:	-- --	PROJECT NAME:	21-028 Framing
LEVEL:	S2.2	LOADING:	ASD
MEMBER NAME:	PST-DB3-2.2A	CODE:	2018 International Building Code
MEMBER TYPE:	COLUMN	NDS:	2018 NDS
MATERIAL:	Solid Sawn		
Douglas Fir-Larch	No. 2	(1) 5.5 X 5.5	DRY

PST-DB3-2.2A DIAGRAM



COLUMN PROPERTIES

Start(ft) 0 End(ft): 8.5

Area	Ix	Iy	BSW	Lams	G	Kcr
(in ²)	(in ⁴)	(in ⁴)	(lbf/ft)			Creep Factor
30.25	76.26	76.26	6.9	1	0.5	1

STRENGTH PROPERTIES

	Fb (psi)	Ft (psi)	Fv (psi)	Fc (psi)	Fc⊥ (psi)	E (psi) x10 ³	Emin (psi) x10 ³
Base Values	750	475	170	700	625	1300	470
Adjusted Values	750	475	170	700	625	1300	470
C _M	1	1	1	1	1	1	1
C _T	1	1	1	1	1	1	1
C _i	1	1	1	1	1	1	1
C _F	1	1	1	1	1	1	1

Bending Adjustment Factors C_{fu} = 1 C_r = 1

COLUMN DATA

Span	Length (ft)	Unbraced Length (ft)		Column End					
		X	Y	Offset	CP	Ke(X Axis)	Ke(Y Axis)	KeL/d (X Axis)	KeL/d (Y Axis)
1	8.5	8.5	8.5	0	0.83	1.00	1.00	18.55	18.55

PASS-FAIL

	PASS/FAIL	MAGNITUDE	STRENGTH	LOCATION (ft)	LOAD COMBO	DURATION FACTOR	CD
Deflection (in)	PASS (95.2%)	0.014 (=L/7499)	0.283 (=L/360)	8.5	D+Lr		
Compressive Stress (psi)	PASS (59.4%)	234.3	577.7	0	D+L		1
Bearing Stress (psi)	PASS (100.0%)	0.2	875.0	8.5	D+Lr		1.25

REACTIONS

Units for V: lbf Units for M: lbf-ft

Z axis	DEAD	LIVE	LIVE ROOF	SNOW	WIND +	WIND -	SEISMIC +	SEISMIC -	ICE	RAIN	EARTH
A	3828	3259	1449	1811	0	0	0	0	0	0	0
B	0	0	0	0	0	0	0	0	0	0	0
Y axis											
A	0	0	0	0	0	0	0	0	0	0	0
B	0	0	3 / -2	1	0	0	0	0	0	0	0

Reaction Location

A

B

LOAD LIST

Type	Left Magnitude	Right Magnitude	Load Start (ft)	Load End (ft)	Load Type	Direction
Self Weight (lbf/ft)	6.9	6.9	0	8.5	Dead	Z

LINKED LOAD LIST

Type	Left Magnitude	Right Magnitude	Load Start (ft)	Load End (ft)	Load Type	Direction
Point (lbf)	-3769.025	-	8.5	-	Dead	Z
Point (lbf)	-3258.915	-	8.5	-	Live	Z
Point (lbf)	1.273669	-	8.5	-	Snow	Y
Point (lbf)	-1811.1	-	8.5	-	Snow	Z
Point (lbf)	-1448.941	-	8.5	-	Roof Live	Z
Point (lbf)	2.918893	-	8.5	-	Roof Live	Y
Point (lbf)	-1.757772	-	8.5	-	Roof Live	Y

DATE:	10/18/2021	COMPANY:	Pacific Northwest Structural Group, Inc
VITRUVIUS BUILD:	Base	DESIGNED BY:	David Starkel
CUSTOMER:		REVIEWED BY:	David Starkel
PROJ. ADDRESS:	-- --	PROJECT NAME:	21-028 Framing
LEVEL:	S2.2	LOADING:	ASD
MEMBER NAME:	PST-FB3-2.2B	CODE:	2018 International Building Code
MEMBER TYPE:	COLUMN	NDS:	2018 NDS
MATERIAL:	Solid Sawn		
Douglas Fir-Larch	No. 2	(1) 5.5 X 5.5	DRY

PST-FB3-2.2B DIAGRAM



COLUMN PROPERTIES

Start(ft) 0 End(ft): 10

Area	Ix	Iy	BSW	Lams	G	Kcr
(in ²)	(in ⁴)	(in ⁴)	(lbf/ft)			Creep Factor
30.25	76.26	76.26	6.9	1	0.5	1

STRENGTH PROPERTIES

	Fb (psi)	Ft (psi)	Fv (psi)	Fc (psi)	Fc⊥ (psi)	E (psi) x10 ³	Emin (psi) x10 ³
Base Values	750	475	170	700	625	1300	470
Adjusted Values	750	475	170	700	625	1300	470
C _M	1	1	1	1	1	1	1
C _T	1	1	1	1	1	1	1
C _i	1	1	1	1	1	1	1
C _F	1	1	1	1	1	1	1

Bending Adjustment Factors C_{fu} = 1 C_r = 1

COLUMN DATA

Span	Length (ft)	Unbraced Length (ft)		Column End					
		X	Y	Offset	CP	Ke(X Axis)	Ke(Y Axis)	KeL/d (X Axis)	KeL/d (Y Axis)
1	10	10	10	0	0.69	1.00	1.00	21.82	21.82

PASS-FAIL

	PASS/FAIL	MAGNITUDE	STRENGTH	LOCATION (ft)	LOAD COMBO	DURATION FACTOR CD
Deflection (in)	PASS (92.9%)	0.024 (=L/5042)	0.333 (=L/360)	10	D+Lr	
Compressive Stress (psi)	PASS (42.5%)	321.2	558.5	0	D+0.75L+0.75S	1.15

REACTIONS

Units for V: lbf Units for M: lbf-ft

Z axis	DEAD	LIVE	LIVE ROOF	SNOW	WIND +	WIND -	SEISMIC +	SEISMIC -	ICE	RAIN	EARTH
A	4746	2787	3073	3841	0	0	0	0	0	0	0
B	0	0	0	0	0	0	0	0	0	0	0
X axis											
A	0	0	0	0	0	0	0	0	0	0	0
B	0	0	3 / -2	1	0	0	0	0	0	0	0

Reaction Location

A

B

LOAD LIST

Type	Left Magnitude	Right Magnitude	Load Start (ft)	Load End (ft)	Load Type	Direction
Self Weight (lbf/ft)	6.9	6.9	0	10	Dead	Z

LINKED LOAD LIST

Type	Left Magnitude	Right Magnitude	Load Start (ft)	Load End (ft)	Load Type	Direction
Point (lbf)	-4677.405	-	10	-	Dead	Z
Point (lbf)	-2786.667	-	10	-	Live	Z
Point (lbf)	-3841.006	-	10	-	Snow	Z
Point (lbf)	-1.273669	-	10	-	Snow	X
Point (lbf)	1.757772	-	10	-	Roof Live	X
Point (lbf)	-3072.984	-	10	-	Roof Live	Z
Point (lbf)	-2.918893	-	10	-	Roof Live	X

DATE:	10/18/2021	COMPANY:	Pacific Northwest Structural Group, Inc
VITRUVIUS BUILD:	Base	DESIGNED BY:	David Starkel
CUSTOMER:		REVIEWED BY:	David Starkel
PROJ. ADDRESS:	-- --	PROJECT NAME:	21-028 Framing
LEVEL:	S2.2	LOADING:	ASD
MEMBER NAME:	PST-FB6-2.2A	CODE:	2018 International Building Code
MEMBER TYPE:	COLUMN	NDS:	2018 NDS
MATERIAL:	Solid Sawn		
Douglas Fir-Larch	No. 2	(1) 3.5 X 5.5	DRY

PST-FB6-2.2A DIAGRAM



COLUMN PROPERTIES

Start(ft) 0 End(ft): 9

Area	Ix	Iy	BSW	Lams	G	Kcr
(in ²)	(in ⁴)	(in ⁴)	(lbf/ft)			Creep Factor
19.25	48.53	19.65	4.39	1	0.5	1

STRENGTH PROPERTIES

	Fb (psi)	Ft (psi)	Fv (psi)	Fc (psi)	Fc⊥ (psi)	E (psi) x10 ³	Emin (psi) x10 ³
Base Values	900	575	180	1350	625	1600	580
Adjusted Values	1170	748	180	1485	625	1600	580
C _M	1	1	1	1	1	1	1
C _T	1	1	1	1	1	1	1
C _i	1	1	1	1	1	1	1
C _F	1.3	1.3	1	1.1	1	1	1

Bending Adjustment Factors C_{fu} = 1 C_r = 1

COLUMN DATA

Span	Length (ft)	Unbraced Length (ft)		Column End					
		X	Y	Offset	CP	Ke(X Axis)	Ke(Y Axis)	KeL/d (X Axis)	KeL/d (Y Axis)
1	9	9	9	0	0.27	1.00	1.00	19.64	30.86

PASS-FAIL

	PASS/FAIL	MAGNITUDE	STRENGTH	LOCATION (ft)	LOAD COMBO	DURATION FACTOR	CD
Deflection (in)	PASS (94.9%)	0.015 (=L/7105)	0.300 (=L/360)	9	D+Lr		
Compressive Stress (psi)	PASS (33.4%)	310.1	465.8	0	D+0.75L+0.75S		1.15
Bearing Stress (psi)	PASS (100.0%)	0.5	1707.8	9	D+S		1.15

REACTIONS

Units for V: lbf Units for M: lbf-ft

Z axis	DEAD	LIVE	LIVE ROOF	SNOW	WIND +	WIND -	SEISMIC +	SEISMIC -	ICE	RAIN	EARTH
A	2399	2444 / -218	1967 / -107	2316	0	0	0	0	0	0	0
B	0	0	0	0	0	0	0	0	0	0	0
Y axis											
A	0	0	0	0	0	0	0	0	0	0	0
B	-2	0	1 / -3	-4	0	0	0	0	0	0	0
X axis											
A	0	0	0	0	0	0	0	0	0	0	0
B	-3	0	0 / -6	0	0	0	0	0	0	0	0

Reaction Location

A

B

LOAD LIST

Type	Left Magnitude	Right Magnitude	Load Start (ft)	Load End (ft)	Load Type	Direction
Self Weight (lbf/ft)	4.39	4.39	0	9	Dead	Z

LINKED LOAD LIST

Type	Left Magnitude	Right Magnitude	Load Start (ft)	Load End (ft)	Load Type	Direction
Point (lbf)	-2.069101	-	9	-	Dead	Y
Point (lbf)	-2359.19	-	9	-	Dead	Z
Point (lbf)	2.571273	-	9	-	Dead	X
Point (lbf)	-3.89418	-	9	-	Snow	Y
Point (lbf)	-2315.983	-	9	-	Snow	Z
Point (lbf)	-0.2858821	-	9	-	Snow	X
Point (lbf)	-2444.114	-	9	-	Live	Z
Point (lbf)	1.029599	-	9	-	Roof Live	Y
Point (lbf)	107.4312	-	9	-	Roof Live	Z
Point (lbf)	6.441796	-	9	-	Roof Live	X
Point (lbf)	-3.133266	-	9	-	Roof Live	Y
Point (lbf)	217.7031	-	9	-	Live	Z
Point (lbf)	-1967.186	-	9	-	Roof Live	Z
Point (lbf)	-0.4226311	-	9	-	Roof Live	X

DATE:	10/18/2021	COMPANY:	Pacific Northwest Structural Group, Inc
VITRUVIUS BUILD:	Base	DESIGNED BY:	David Starkel
CUSTOMER:		REVIEWED BY:	David Starkel
PROJ. ADDRESS:	-- --	PROJECT NAME:	21-028 Framing
LEVEL:	S2.2	LOADING:	ASD
MEMBER NAME:	PST-FB6-2.2B	CODE:	2018 International Building Code
MEMBER TYPE:	COLUMN	NDS:	2018 NDS
MATERIAL:	Solid Sawn		
Douglas Fir-Larch	No. 2	(1) 3.5 X 5.5	DRY

PST-FB6-2.2B DIAGRAM



COLUMN PROPERTIES

Start(ft) 0 End(ft): 9

Area	Ix	Iy	BSW	Lams	G	Kcr
(in ²)	(in ⁴)	(in ⁴)	(lbf/ft)			Creep Factor
19.25	48.53	19.65	4.39	1	0.5	1

STRENGTH PROPERTIES

	Fb (psi)	Ft (psi)	Fv (psi)	Fc (psi)	Fc⊥ (psi)	E (psi) x10 ³	Emin (psi) x10 ³
Base Values	900	575	180	1350	625	1600	580
Adjusted Values	1170	748	180	1485	625	1600	580
C _M	1	1	1	1	1	1	1
C _T	1	1	1	1	1	1	1
C _i	1	1	1	1	1	1	1
C _F	1.3	1.3	1	1.1	1	1	1

Bending Adjustment Factors C_{fu} = 1 C_r = 1

COLUMN DATA

Span	Length (ft)	Unbraced Length (ft)		Column End					
		X	Y	Offset	CP	Ke(X Axis)	Ke(Y Axis)	KeL/d (X Axis)	KeL/d (Y Axis)
1	9	9	1	0	0.57	1.00	1.00	19.64	3.43

PASS-FAIL

	PASS/FAIL	MAGNITUDE	STRENGTH	LOCATION (ft)	LOAD COMBO	DURATION FACTOR CD
Deflection (in)	PASS (87.2%)	0.039 (=L/2805)	0.300 (=L/360)	9	D+Lr	
Compressive Stress (psi)	PASS (20.5%)	776.0	976.1	0	D+0.75L+0.75S	1.15

REACTIONS

Units for V: lbf Units for M: lbf-ft

Z axis	DEAD	LIVE	LIVE ROOF	SNOW	WIND +	WIND -	SEISMIC +	SEISMIC -	ICE	RAIN	EARTH
A	6180	5954	4818 / -92	5723	0	0	0	0	0	0	0
B	0	0	0	0	0	0	0	0	0	0	0
X axis											
A	0	0	0	0	0	0	0	0	0	0	0
B	-4	0	1 / -10	1	0	0	0	0	0	0	0

Reaction Location

A

B

LOAD LIST

Type	Left Magnitude	Right Magnitude	Load Start (ft)	Load End (ft)	Load Type	Direction
Self Weight (lbf/ft)	4.39	4.39	0	9	Dead	Z

LINKED LOAD LIST

Type	Left Magnitude	Right Magnitude	Load Start (ft)	Load End (ft)	Load Type	Direction
Point (lbf)	-6140.387	-	9	-	Dead	Z
Point (lbf)	3.94452	-	9	-	Dead	X
Point (lbf)	-5954.472	-	9	-	Live	Z
Point (lbf)	-5723.145	-	9	-	Snow	Z
Point (lbf)	-0.5075927	-	9	-	Snow	X
Point (lbf)	92.39405	-	9	-	Roof Live	Z
Point (lbf)	9.868913	-	9	-	Roof Live	X
Point (lbf)	-4818.333	-	9	-	Roof Live	Z
Point (lbf)	-0.7833914	-	9	-	Roof Live	X

DATE:	10/18/2021	COMPANY:	Pacific Northwest Structural Group, Inc
VITRUVIUS BUILD:	Base	DESIGNED BY:	David Starkel
CUSTOMER:		REVIEWED BY:	David Starkel
PROJ. ADDRESS:	--	PROJECT NAME:	21-028 Framing
	--		
LEVEL:	S2.2	LOADING:	ASD
MEMBER NAME:	PST-FB6-2.2C-FB5-2.2A	CODE:	2018 International Building Code
MEMBER TYPE:	COLUMN	NDS:	2018 NDS
MATERIAL:	Solid Sawn		
Douglas Fir-Larch	No. 2	(1) 3.5 X 5.5	DRY

PST-FB6-2.2C-FB5-2.2A DIAGRAM



COLUMN PROPERTIES

Start(ft) 0 End(ft): 9

Area	Ix	Iy	BSW	Lams	G	Kcr
(in ²)	(in ⁴)	(in ⁴)	(lbf/ft)			Creep Factor
19.25	48.53	19.65	4.39	1	0.5	1

STRENGTH PROPERTIES

	Fb (psi)	Ft (psi)	Fv (psi)	Fc (psi)	Fc⊥ (psi)	E (psi) x10 ³	Emin (psi) x10 ³
Base Values	900	575	180	1350	625	1600	580
Adjusted Values	1170	748	180	1485	625	1600	580
C _M	1	1	1	1	1	1	1
C _T	1	1	1	1	1	1	1
C _i	1	1	1	1	1	1	1
C _F	1.3	1.3	1	1.1	1	1	1

Bending Adjustment Factors C_{fu} = 1 C_r = 1

COLUMN DATA

Span	Length (ft)	Unbraced Length (ft)		Column End					
		X	Y	Offset	CP	Ke(X Axis)	Ke(Y Axis)	KeL/d (X Axis)	KeL/d (Y Axis)
1	9	9	1	0	0.54	1.00	1.00	19.64	3.43

PASS-FAIL

	PASS/FAIL	MAGNITUDE	STRENGTH	LOCATION (ft)	LOAD COMBO	DURATION FACTOR CD
Deflection (in)	PASS (92.6%)	0.022 (=L/4843)	0.300 (=L/360)	9	D+Lr	
Compressive Stress (psi)	PASS (63.2%)	369.0	1001.7	0	D+0.75L+0.75Lr	1.25

REACTIONS

Units for V: lbf Units for M: lbf-ft

Z axis	DEAD	LIVE	LIVE ROOF	SNOW	WIND +	WIND -	SEISMIC +	SEISMIC -	ICE	RAIN	EARTH
A	3079	2076 / -391	3289 / -283	2212	0	0	0	0	0	0	0
B	0	0	0	0	0	0	0	0	0	0	0
X axis											
A	0	0	0	0	0	0	0	0	0	0	0
B	-1	0	1 / -4	0	0	0	0	0	0	0	0

Reaction Location

A

B

LOAD LIST

Type	Left Magnitude	Right Magnitude	Load Start (ft)	Load End (ft)	Load Type	Direction
Self Weight (lbf/ft)	4.39	4.39	0	9	Dead	Z

LINKED LOAD LIST

Type	Left Magnitude	Right Magnitude	Load Start (ft)	Load End (ft)	Load Type	Direction
Point (lbf)	-1222.475	-	9	-	Dead	Z
Point (lbf)	0.4852938	-	9	-	Dead	X
Point (lbf)	-368.6545	-	9	-	Live	Z
Point (lbf)	-809.9343	-	9	-	Snow	Z
Point (lbf)	1.476055	-	9	-	Roof Live	X
Point (lbf)	-1295.656	-	9	-	Roof Live	Z
Point (lbf)	-0.4413353	-	9	-	Roof Live	X
Point (lbf)	-1816.526	-	9	-	Dead	Z
Point (lbf)	0.4763518	-	9	-	Dead	X
Point (lbf)	-1402.287	-	9	-	Snow	Z
Point (lbf)	-0.2682381	-	9	-	Snow	X
Point (lbf)	-1707.088	-	9	-	Live	Z
Point (lbf)	283.1348	-	9	-	Roof Live	Z
Point (lbf)	2.225126	-	9	-	Roof Live	X
Point (lbf)	390.5283	-	9	-	Live	Z
Point (lbf)	-1993.789	-	9	-	Roof Live	Z
Point (lbf)	-0.6626288	-	9	-	Roof Live	X

DATE:	10/18/2021	COMPANY:	Pacific Northwest Structural Group, Inc
VITRUVIUS BUILD:	Base	DESIGNED BY:	David Starkel
CUSTOMER:		REVIEWED BY:	David Starkel
PROJ. ADDRESS:	-- --	PROJECT NAME:	21-028 Framing
LEVEL:	S2.2	LOADING:	ASD
MEMBER NAME:	PST-FB7-2.2B	CODE:	2018 International Building Code
MEMBER TYPE:	COLUMN	NDS:	2018 NDS
MATERIAL:	Solid Sawn		
Douglas Fir-Larch	No. 2	(1) 3.5 X 3.5	DRY

PST-FB7-2.2B DIAGRAM



COLUMN PROPERTIES

Start(ft) 0 End(ft): 9

Area	Ix	Iy	BSW	Lams	G	Kcr
(in ²)	(in ⁴)	(in ⁴)	(lbf/ft)			Creep Factor
12.25	12.51	12.51	2.79	1	0.5	1

STRENGTH PROPERTIES

	Fb (psi)	Ft (psi)	Fv (psi)	Fc (psi)	Fc⊥ (psi)	E (psi) x10 ³	Emin (psi) x10 ³
Base Values	900	575	180	1350	625	1600	580
Adjusted Values	1350	862	180	1552	625	1600	580
C _M	1	1	1	1	1	1	1
C _T	1	1	1	1	1	1	1
C _i	1	1	1	1	1	1	1
C _F	1.5	1.5	1	1.15	1	1	1

Bending Adjustment Factors C_{fu} = 1 C_r = 1

COLUMN DATA

Span	Length (ft)	Unbraced Length (ft)		Column End					
		X	Y	Offset	CP	Ke(X Axis)	Ke(Y Axis)	KeL/d (X Axis)	KeL/d (Y Axis)
1	9	9	9	0	0.30	1.00	1.00	30.86	30.86

PASS-FAIL

	PASS/FAIL	MAGNITUDE	STRENGTH	LOCATION (ft)	LOAD COMBO	DURATION FACTOR	CD
Deflection (in)	PASS (95.9%)	0.012 (=L/8780)	0.300 (=L/360)	9	L		
Compressive Stress (psi)	PASS (14.6%)	394.5	461.6	0	D+L		1

REACTIONS

Units for V: lbf Units for M: lbf-ft

Z axis	DEAD	LIVE	LIVE ROOF	SNOW	WIND +	WIND -	SEISMIC +	SEISMIC -	ICE	RAIN	EARTH
A	2595	2237	0	688	0	0	0	0	0	0	0
B	0	0	0	0	0	0	0	0	0	0	0

Reaction Location

A

B

LOAD LIST

Type	Left Magnitude	Right Magnitude	Load Start (ft)	Load End (ft)	Load Type	Direction
Self Weight (lbf/ft)	2.79	2.79	0	9	Dead	Z

LINKED LOAD LIST

Type	Left Magnitude	Right Magnitude	Load Start (ft)	Load End (ft)	Load Type	Direction
Point (lbf)	-2570.1	-	9	-	Dead	Z
Point (lbf)	-2236.799	-	9	-	Live	Z
Point (lbf)	-688.0073	-	9	-	Snow	Z

DATE:	10/18/2021	COMPANY:	Pacific Northwest Structural Group, Inc
VITRUVIUS BUILD:	Base	DESIGNED BY:	David Starkel
CUSTOMER:		REVIEWED BY:	David Starkel
PROJ. ADDRESS:	-- --	PROJECT NAME:	21-028 Framing
LEVEL:	S2.2	LOADING:	ASD
MEMBER NAME:	PST-FB9-2.2A	CODE:	2018 International Building Code
MEMBER TYPE:	COLUMN	NDS:	2018 NDS
MATERIAL:	Solid Sawn		
Douglas Fir-Larch	No. 2	(1) 5.5 X 5.5	DRY

PST-FB9-2.2A DIAGRAM



COLUMN PROPERTIES

Start(ft) 0 End(ft): 8.08333

Area	Ix	Iy	BSW	Lams	G	Kcr
(in ²)	(in ⁴)	(in ⁴)	(lbf/ft)			Creep Factor
30.25	76.26	76.26	6.9	1	0.5	1

STRENGTH PROPERTIES

	Fb (psi)	Ft (psi)	Fv (psi)	Fc (psi)	Fc⊥ (psi)	E (psi) x10 ³	Emin (psi) x10 ³
Base Values	750	475	170	700	625	1300	470
Adjusted Values	750	475	170	700	625	1300	470
C _M	1	1	1	1	1	1	1
C _T	1	1	1	1	1	1	1
C _i	1	1	1	1	1	1	1
C _F	1	1	1	1	1	1	1

Bending Adjustment Factors C_{fu} = 1 C_r = 1

COLUMN DATA

Span	Length (ft)	Unbraced Length (ft)		Column End					
		X	Y	Offset	CP	Ke(X Axis)	Ke(Y Axis)	KeL/d (X Axis)	KeL/d (Y Axis)
1	8.08333	8.08333	8.08333	0	0.85	1.00	1.00	17.64	17.64

PASS-FAIL

	PASS/FAIL	MAGNITUDE	STRENGTH	LOCATION (ft)	LOAD COMBO	DURATION FACTOR	CD
Compressive Stress (psi)	PASS (36.4%)	376.5	592.1	0	D+L	1	

REACTIONS

Units for V: lbf Units for M: lbf-ft

Z axis	DEAD	LIVE	LIVE ROOF	SNOW	WIND +	WIND -	SEISMIC +	SEISMIC -	ICE	RAIN	EARTH
A	5462	5928	2596	3245	0	0	0	0	0	0	0
B	0	0	0	0	0	0	0	0	0	0	0

Reaction Location

A

B

LOAD LIST

Type	Left Magnitude	Right Magnitude	Load Start (ft)	Load End (ft)	Load Type	Direction
Self Weight (lbf/ft)	6.9	6.9	0	8.08333	Dead	Z

LINKED LOAD LIST

Type	Left Magnitude	Right Magnitude	Load Start (ft)	Load End (ft)	Load Type	Direction
Point (lbf)	-5406.083	-	8.08333	-	Dead	Z
Point (lbf)	-5927.698	-	8.08333	-	Live	Z
Point (lbf)	-3244.844	-	8.08333	-	Snow	Z
Point (lbf)	-2595.984	-	8.08333	-	Roof Live	Z

DATE:	10/18/2021	COMPANY:	Pacific Northwest Structural Group, Inc
VITRUVIUS BUILD:	Base	DESIGNED BY:	David Starkel
CUSTOMER:		REVIEWED BY:	David Starkel
PROJ. ADDRESS:	-- --	PROJECT NAME:	21-028 Framing
LEVEL:	S2.3	LOADING:	ASD
MEMBER NAME:	RB1-2.3	CODE:	2018 International Building Code
MEMBER TYPE:	ROOF BEAM	NDS:	2018 NDS
MATERIAL:	Solid Sawn		
Douglas Fir-Larch	No. 2	(1) 3.5 X 7.25	DRY

RB1-2.3 DIAGRAM



BEAM PROPERTIES

Start (ft): 0 End (ft): 6.833 Member Slope: 0/12 Actual Length (ft): 6.83 Roof Pitch: 0/12

Area	I _x	I _y	BSW	Lams	G	K _{cr}
(in ²)	(in ⁴)	(in ⁴)	(lbf/ft)			Creep Factor
25.38	111.15	25.9	5.79	1	0.5	1

STRENGTH PROPERTIES

	F _b (psi)	F _t (psi)	F _v (psi)	F _c (psi)	F _{c⊥} (psi)	E (psi) x10 ³	E _{min} (psi) x10 ³
Base Values	900	575	180	1350	625	1600	580
Adjusted Values	1170	690	180	1417	625	1600	580
C _M	1	1	1	1	1	1	1
C _T	1	1	1	1	1	1	1
C _i	1	1	1	1	1	1	1
C _F	1.3	1.2	1	1.05	1	1	1

Bending Adjustment Factors C_{fu} = 1 C_r = 1

BEAM DATA

Span	Length (ft)	Unbraced Length (ft)		Beam End				
		Top	Bottom	Elev. Diff (ft)	CL(Top)	CL(Bottom)	CL(Left)	CL(Right)
1	6.8334	0	6.8334	0	1.00	0.99	1.00	1.00

PASS-FAIL

	PASS/FAIL	MAGNITUDE	STRENGTH	LOCATION (ft)	LOAD COMBO	DURATION FACTOR CD
Shear Stress Y (psi)	PASS (46.7%)	110.4	207.0	0	D+S	1.15
Bending Stress Y (psi)	PASS (7.2%)	1248.8	1345.5	3.42	D+S	1.15
Shear Stress X (psi)	PASS (99.9%)	0.2	207.0	0	D+S	1.15
Bending Stress X (psi)	PASS (99.6%)	5.0	1344.3	3.42	D+S	1.15
Deflection (in)	PASS (71.0%)	0.132 (=L/621)	0.456 (=L/180)	3.42	D+Lr	
Bearing Stress (psi)	PASS (75.6%)	152.5	625.0	0	D+S	1.15

REACTIONS

Units for V: lbf Units for M: lbf-ft

Y axis	DEAD	LIVE	LIVE ROOF	SNOW	WIND +	WIND -	SEISMIC +	SEISMIC -	ICE	RAIN	EARTH
A	712	0	924	1155	0	0	0	0	0	0	0
B	712	0	924	1155	0	0	0	0	0	0	0
X axis											
A	1	0	2	3	0	0	0	0	0	0	0
B	1	0	2	3	0	0	0	0	0	0	0

Reaction Location

A

B

LOAD LIST

Type	Left Magnitude	Right Magnitude	Load Start (ft)	Load End (ft)	Load Type	Direction
Self Weight (lbf/ft)	5.79	5.79	0	6.8334	Dead	Y

LINKED LOAD LIST

Type	Left Magnitude	Right Magnitude	Load Start (ft)	Load End (ft)	Load Type	Direction
Uniform (lbf/ft)	-0.3027921	-0.3027921	0	6.8334	Dead	X
Uniform (lbf/ft)	202.6862	202.6862	0	6.8334	Dead	Y
Uniform (lbf/ft)	-0.758234	-0.758234	0	6.8334	Snow	X
Uniform (lbf/ft)	338.1744	338.1744	0	6.8334	Snow	Y
Uniform (lbf/ft)	-0.4585218	-0.4585218	0	6.8334	Roof Live	X
Uniform (lbf/ft)	270.4559	270.4559	0	6.8334	Roof Live	Y

DATE:	10/18/2021	COMPANY:	Pacific Northwest Structural Group, Inc
VITRUVIUS BUILD:	Base	DESIGNED BY:	David Starkel
CUSTOMER:		REVIEWED BY:	David Starkel
PROJ. ADDRESS:	--	PROJECT NAME:	21-028 Framing
	--		
LEVEL:	S2.3	LOADING:	ASD
MEMBER NAME:	RB2-2.3	CODE:	2018 International Building Code
MEMBER TYPE:	ROOF BEAM	NDS:	2018 NDS
MATERIAL:	Solid Sawn		
Douglas Fir-Larch	No. 2	(1) 3.5 X 7.25	DRY

RB2-2.3 DIAGRAM



BEAM PROPERTIES

Start (ft): 0 End (ft): 4.667 Member Slope: 0/12 Actual Length (ft): 4.67 Roof Pitch: 0/12

Area	Ix	Iy	BSW	Lams	G	Kcr
(in ²)	(in ⁴)	(in ⁴)	(lbf/ft)			Creep Factor
25.38	111.15	25.9	5.79	1	0.5	1

STRENGTH PROPERTIES

	Fb (psi)	Ft (psi)	Fv (psi)	Fc (psi)	Fc⊥ (psi)	E (psi) x10 ³	Emin (psi) x10 ³
Base Values	900	575	180	1350	625	1600	580
Adjusted Values	1170	690	180	1417	625	1600	580
C _M	1	1	1	1	1	1	1
C _T	1	1	1	1	1	1	1
C _i	1	1	1	1	1	1	1
C _F	1.3	1.2	1	1.05	1	1	1

Bending Adjustment Factors C_{fu} = 1 C_r = 1

BEAM DATA

Span	Length (ft)	Unbraced Length (ft)		Beam End				
		Top	Bottom	Elev. Diff (ft)	CL(Top)	CL(Bottom)	CL(Left)	CL(Right)
1	4.667	0	4.667	0	1.00	0.99	1.00	1.00

PASS-FAIL

	PASS/FAIL	MAGNITUDE	STRENGTH	LOCATION (ft)	LOAD COMBO	DURATION FACTOR CD
Shear Stress Y (psi)	PASS (59.3%)	84.2	207.0	0	D+S	1.15
Bending Stress Y (psi)	PASS (51.7%)	650.2	1345.5	2.33	D+S	1.25
Shear Stress X (psi)	PASS (99.8%)	0.4	225.0	0	D+Lr	1.15
Bending Stress X (psi)	PASS (99.5%)	6.6	1461.6	2.33	D+Lr	1.25
Deflection (in)	PASS (89.7%)	0.032 (=L/1744)	0.311 (=L/180)	2.33	D+Lr	
Bearing Stress (psi)	PASS (81.4%)	116.2	625.0	0	D+S	1.15

REACTIONS

Units for V: lbf Units for M: lbf-ft

Y axis	DEAD	LIVE	LIVE ROOF	SNOW	WIND +	WIND -	SEISMIC +	SEISMIC -	ICE	RAIN	EARTH
A	542	0	705	882	0	0	0	0	0	0	0
B	542	0	705	882	0	0	0	0	0	0	0
X axis											
A	2	0	5	-1	0	0	0	0	0	0	0
B	2	0	5	-1	0	0	0	0	0	0	0

Reaction Location

A

B

LOAD LIST

Type	Left Magnitude	Right Magnitude	Load Start (ft)	Load End (ft)	Load Type	Direction
Self Weight (lbf/ft)	5.79	5.79	0	4.667	Dead	Y

LINKED LOAD LIST

Type	Left Magnitude	Right Magnitude	Load Start (ft)	Load End (ft)	Load Type	Direction
Uniform (lbf/ft)	-0.858579	-0.858579	0	4.667	Dead	X
Uniform (lbf/ft)	226.5237	226.5237	0	4.667	Dead	Y
Uniform (lbf/ft)	0.3180531	0.3180531	0	4.667	Snow	X
Uniform (lbf/ft)	377.8576	377.8576	0	4.667	Snow	Y
Uniform (lbf/ft)	-2.145077	-2.145077	0	4.667	Roof Live	X
Uniform (lbf/ft)	301.9083	301.9083	0	4.667	Roof Live	Y

DATE:	10/18/2021	COMPANY:	Pacific Northwest Structural Group, Inc
VITRUVIUS BUILD:	Base	DESIGNED BY:	David Starkel
CUSTOMER:		REVIEWED BY:	David Starkel
PROJ. ADDRESS:	-- --	PROJECT NAME:	21-028 Framing
LEVEL:	S2.3	LOADING:	ASD
MEMBER NAME:	RB3-2.3	CODE:	2018 International Building Code
MEMBER TYPE:	ROOF BEAM	NDS:	2018 NDS
MATERIAL:	Solid Sawn		
Douglas Fir-Larch	No. 2	(1) 3.5 X 7.25	DRY

RB3-2.3 DIAGRAM



BEAM PROPERTIES

Start (ft): 0 End (ft): 5.333 Member Slope: 0/12 Actual Length (ft): 5.33 Roof Pitch: 0/12

Area	Ix	Iy	BSW	Lams	G	Kcr
(in ²)	(in ⁴)	(in ⁴)	(lbf/ft)			Creep Factor
25.38	111.15	25.9	5.79	1	0.5	1

STRENGTH PROPERTIES

	Fb (psi)	Ft (psi)	Fv (psi)	Fc (psi)	Fc⊥ (psi)	E (psi) x10 ³	Emin (psi) x10 ³
Base Values	900	575	180	1350	625	1600	580
Adjusted Values	1170	690	180	1417	625	1600	580
C _M	1	1	1	1	1	1	1
C _T	1	1	1	1	1	1	1
C _i	1	1	1	1	1	1	1
C _F	1.3	1.2	1	1.05	1	1	1

Bending Adjustment Factors C_{fu} = 1 C_r = 1

BEAM DATA

Span	Length (ft)	Unbraced Length (ft)		Beam End				
		Top	Bottom	Elev. Diff (ft)	CL(Top)	CL(Bottom)	CL(Left)	CL(Right)
1	5.3334	0	5.3334	0	1.00	0.99	1.00	1.00

PASS-FAIL

	PASS/FAIL	MAGNITUDE	STRENGTH	LOCATION (ft)	LOAD COMBO	DURATION FACTOR CD
Shear Stress Y (psi)	PASS (62.6%)	77.5	207.0	0	D+S	1.15
Bending Stress Y (psi)	PASS (49.2%)	684.1	1345.5	2.67	D+S	1.25
Shear Stress X (psi)	PASS (100.0%)	0.0	225.0	0	D+Lr	1.15
Bending Stress X (psi)	PASS (99.9%)	0.9	1461.4	2.67	D+Lr	1.25
Deflection (in)	PASS (87.6%)	0.044 (=L/1451)	0.356 (=L/180)	2.67	D+Lr	
Bearing Stress (psi)	PASS (82.9%)	107.0	625.0	0	D+S	1.15

REACTIONS

Units for V: lbf Units for M: lbf-ft

Y axis	DEAD	LIVE	LIVE ROOF	SNOW	WIND +	WIND -	SEISMIC +	SEISMIC -	ICE	RAIN	EARTH
A	501	0	648	810	0	0	0	0	0	0	0
B	501	0	648	810	0	0	0	0	0	0	0
X axis											
A	0	0	0 / -1	0	0	0	0	0	0	0	0
B	0	0	0 / -1	0	0	0	0	0	0	0	0

Reaction Location

A

B

LOAD LIST

Type	Left Magnitude	Right Magnitude	Load Start (ft)	Load End (ft)	Load Type	Direction
Self Weight (lbf/ft)	5.79	5.79	0	5.3334	Dead	Y

LINKED LOAD LIST

Type	Left Magnitude	Right Magnitude	Load Start (ft)	Load End (ft)	Load Type	Direction
Uniform (lbf/ft)	182.1962	182.1962	0	5.3334	Dead	Y
Uniform (lbf/ft)	0.1340704	0.1340704	0	5.3334	Snow	X
Uniform (lbf/ft)	303.5977	303.5977	0	5.3334	Snow	Y
Uniform (lbf/ft)	242.897	242.897	0	5.3334	Roof Live	Y
Uniform (lbf/ft)	0.3072519	0.3072519	0	5.3334	Roof Live	X
Uniform (lbf/ft)	-0.1850286	-0.1850286	0	5.3334	Roof Live	X

DATE:	10/18/2021	COMPANY:	Pacific Northwest Structural Group, Inc
VITRUVIUS BUILD:	Base	DESIGNED BY:	David Starkel
CUSTOMER:		REVIEWED BY:	David Starkel
PROJ. ADDRESS:	--	PROJECT NAME:	21-028 Framing
	--		
LEVEL:	S2.3	LOADING:	ASD
MEMBER NAME:	RB4-2.3	CODE:	2018 International Building Code
MEMBER TYPE:	ROOF BEAM	NDS:	2018 NDS
MATERIAL:	Solid Sawn		
Douglas Fir-Larch	No. 2	(1) 3.5 X 9.25	DRY

RB4-2.3 DIAGRAM



BEAM PROPERTIES

Start (ft): 0 End (ft): 7.5 Member Slope: 0/12 Actual Length (ft): 7.5 Roof Pitch: 0/12

Area	Ix	Iy	BSW	Lams	G	Kcr
(in ²)	(in ⁴)	(in ⁴)	(lbf/ft)			Creep Factor
32.38	230.84	33.05	7.38	1	0.5	1

STRENGTH PROPERTIES

	Fb (psi)	Ft (psi)	Fv (psi)	Fc (psi)	Fc⊥ (psi)	E (psi) x10 ³	Emin (psi) x10 ³
Base Values	900	575	180	1350	625	1600	580
Adjusted Values	1080	632	180	1350	625	1600	580
C _M	1	1	1	1	1	1	1
C _T	1	1	1	1	1	1	1
C _i	1	1	1	1	1	1	1
C _F	1.2	1.1	1	1	1	1	1

Bending Adjustment Factors C_{fu} = 1 C_r = 1

BEAM DATA

Span	Length (ft)	Unbraced Length (ft)		Beam End				
		Top	Bottom	Elev. Diff (ft)	CL(Top)	CL(Bottom)	CL(Left)	CL(Right)
1	7.5	0	7.5	0	1.00	0.99	1.00	1.00

PASS-FAIL

	PASS/FAIL	MAGNITUDE	STRENGTH	LOCATION (ft)	LOAD COMBO	DURATION FACTOR CD
Shear Stress Y (psi)	PASS (53.0%)	97.4	207.0	7.5	D+S	1.15
Bending Stress Y (psi)	PASS (23.7%)	947.5	1242.0	3.75	D+S	0.9
Shear Stress X (psi)	PASS (100.0%)	0.0	162.0	0	D	1.15
Bending Stress X (psi)	PASS (99.9%)	0.6	971.6	3.75	D	0.9
Deflection (in)	PASS (81.1%)	0.095 (=L/950)	0.500 (=L/180)	3.75	D+Lr	
Bearing Stress (psi)	PASS (72.5%)	171.6	625.0	7.5	D+S	1.15

REACTIONS

Units for V: lbf Units for M: lbf-ft

Y axis	DEAD	LIVE	LIVE ROOF	SNOW	WIND +	WIND -	SEISMIC +	SEISMIC -	ICE	RAIN	EARTH
A	805	0	1037	1296	0	0	0	0	0	0	0
B	805	0	1037	1296	0	0	0	0	0	0	0
X axis											
A	0	0	-1	0	0	0	0	0	0	0	0
B	0	0	-1	0	0	0	0	0	0	0	0

Reaction Location

A

B

LOAD LIST

Type	Left Magnitude	Right Magnitude	Load Start (ft)	Load End (ft)	Load Type	Direction
Self Weight (lbf/ft)	7.38	7.38	0	7.5	Dead	Y

LINKED LOAD LIST

Type	Left Magnitude	Right Magnitude	Load Start (ft)	Load End (ft)	Load Type	Direction
Uniform (lbf/ft)	-0.1328855	-0.1328855	0	7.5	Dead	X
Uniform (lbf/ft)	207.3935	207.3935	0	7.5	Dead	Y
Uniform (lbf/ft)	345.697	345.697	0	7.5	Snow	Y
Uniform (lbf/ft)	276.4824	276.4824	0	7.5	Roof Live	Y
Uniform (lbf/ft)	0.182497	0.182497	0	7.5	Roof Live	X

DATE:	10/18/2021	COMPANY:	Pacific Northwest Structural Group, Inc
VITRUVIUS BUILD:	Base	DESIGNED BY:	David Starkel
CUSTOMER:		REVIEWED BY:	David Starkel
PROJ. ADDRESS:	-- --	PROJECT NAME:	21-028 Framing
LEVEL:	S2.3	LOADING:	ASD
MEMBER NAME:	RB5-2.3	CODE:	2018 International Building Code
MEMBER TYPE:	ROOF BEAM	NDS:	2018 NDS
MATERIAL:	Glulams		
Stress Class Rated 24F-1.8E	24F-V4 DF/DF	(1) 3.5 X 12	DRY

RB5-2.3 DIAGRAM



BEAM PROPERTIES

Start (ft): 0 End (ft): 7 Member Slope: 0/12 Actual Length (ft): 7 Roof Pitch: 0/12

Area	Ix	Iy	BSW	Lams	G	Kcr
(in ²)	(in ⁴)	(in ⁴)	(lbf/ft)			Creep Factor
42	504	42.88	9.58	1	0.5	1

STRENGTH PROPERTIES

	Fbx+	Fbx-	Fby	Ft	Fvx	Fvy	Fc	Fc⊥	Ex	Exmin	Ey	Eymin
	(psi)	(psi)	(psi)	(psi)	(psi)	(psi)	(psi)	(psi)	(psi)	(psi)	(psi)	(psi)
Base Values	2400	1850	1450	1100	265	230	1650	650	1800000	950000	1600000	850000
Adjusted Values	2400	1850	1450	1100	265	230	1650	650	1800000	950000	1600000	850000
C _M	1	1	1	1	1	1	1	1	1	1	1	1
C _T	1	1	1	1	1	1	1	1	1	1	1	1
Bending Adjustment Factors	C _{VR} = 1											

BEAM DATA

Span	Length (ft)	Unbraced Length (ft)		Beam End				
		Top	Bottom	Elev. Diff (ft)	CL(Top)	CL(Bottom)	CL(Left)	CL(Right)
1	7	0	7	0	1.00	0.98	1.00	1.00

PASS-FAIL

	PASS/FAIL	MAGNITUDE	STRENGTH	LOCATION (ft)	LOAD COMBO	DURATION FACTOR CD
Shear Stress Y (psi)	PASS (72.0%)	85.3	304.8	0	D+S	1.15
Bending Stress Y (psi)	PASS (78.4%)	597.2	2760.0	3.5	D+S	1.15
Shear Stress X (psi)	PASS (100.0%)	0.0	264.5	0	D+S	1.15
Bending Stress X (psi)	PASS (100.0%)	0.6	1667.1	3.5	D+S	1.15
Deflection (in)	PASS (92.2%)	0.036 (=L/2321)	0.467 (=L/180)	3.5	D+Lr	
Bearing Stress (psi)	PASS (70.0%)	195.0	650.0	0	D+S	1.15

REACTIONS

Units for V: lbf Units for M: lbf-ft

Y axis	DEAD	LIVE	LIVE ROOF	SNOW	WIND +	WIND -	SEISMIC +	SEISMIC -	ICE	RAIN	EARTH
A	917	0	1212 / -35	1472	0	0	0	0	0	0	0
B	917	0	1212 / -35	1472	0	0	0	0	0	0	0
X axis											
A	0	0	-1	-1	0	0	0	0	0	0	0
B	0	0	-1	-1	0	0	0	0	0	0	0

Reaction Location

A

B

LOAD LIST

Type	Left Magnitude	Right Magnitude	Load Start (ft)	Load End (ft)	Load Type	Direction
Self Weight (lb/ft)	9.58	9.58	0	7	Dead	Y

LINKED LOAD LIST

Type	Left Magnitude	Right Magnitude	Load Start (ft)	Load End (ft)	Load Type	Direction
Uniform (lb/ft)	137.2861	137.2861	0	7	Dead	Y
Uniform (lb/ft)	0.1838779	0.1838779	0	7	Snow	X
Uniform (lb/ft)	228.8101	228.8101	0	7	Snow	Y
Uniform (lb/ft)	190.9396	190.9396	0	7	Roof Live	Y
Uniform (lb/ft)	0.1470861	0.1470861	0	7	Roof Live	X
Uniform (lb/ft)	-7.912623	-7.912623	0	7	Roof Live	Y
Uniform (lb/ft)	115.0754	115.0754	0	7	Dead	Y
Uniform (lb/ft)	191.7908	191.7908	0	7	Snow	Y
Uniform (lb/ft)	155.4517	155.4517	0	7	Roof Live	Y
Uniform (lb/ft)	-2.025301	-2.025301	0	7	Roof Live	Y

DATE:	10/18/2021	COMPANY:	Pacific Northwest Structural Group, Inc
VITRUVIUS BUILD:	Base	DESIGNED BY:	David Starkel
CUSTOMER:		REVIEWED BY:	David Starkel
PROJ. ADDRESS:	-- --	PROJECT NAME:	21-028 Framing
LEVEL:	S2.3	LOADING:	ASD
MEMBER NAME:	RB6-2.3	CODE:	2018 International Building Code
MEMBER TYPE:	ROOF BEAM	NDS:	2018 NDS
MATERIAL:	Solid Sawn		
Douglas Fir-Larch	No. 2	(1) 3.5 X 7.25	DRY

RB6-2.3 DIAGRAM



BEAM PROPERTIES

Start (ft): 0 End (ft): 6.667 Member Slope: 0/12 Actual Length (ft): 6.67 Roof Pitch: 0/12

Area	Ix	Iy	BSW	Lams	G	Kcr
(in ²)	(in ⁴)	(in ⁴)	(lbf/ft)			Creep Factor
25.38	111.15	25.9	5.79	1	0.5	1

STRENGTH PROPERTIES

	Fb (psi)	Ft (psi)	Fv (psi)	Fc (psi)	Fc⊥ (psi)	E (psi) x10 ³	Emin (psi) x10 ³
Base Values	900	575	180	1350	625	1600	580
Adjusted Values	1170	690	180	1417	625	1600	580
C _M	1	1	1	1	1	1	1
C _T	1	1	1	1	1	1	1
C _i	1	1	1	1	1	1	1
C _F	1.3	1.2	1	1.05	1	1	1

Bending Adjustment Factors C_{fu} = 1 C_r = 1

BEAM DATA

Span	Length (ft)	Unbraced Length (ft)		Beam End				
		Top	Bottom	Elev. Diff (ft)	CL(Top)	CL(Bottom)	CL(Left)	CL(Right)
1	6.667	0	6.667	0	1.00	0.99	1.00	1.00

PASS-FAIL

	PASS/FAIL	MAGNITUDE	STRENGTH	LOCATION (ft)	LOAD COMBO	DURATION FACTOR CD
Shear Stress Y (psi)	PASS (62.7%)	77.2	207.0	6.67	D+S	1.15
Bending Stress Y (psi)	PASS (36.7%)	851.8	1345.5	3.33	D+S	1.15
Deflection (in)	PASS (80.7%)	0.086 (=L/933)	0.445 (=L/180)	3.33	D+Lr	
Bearing Stress (psi)	PASS (82.9%)	106.6	625.0	0	D+S	1.15

REACTIONS

Units for V: lbf Units for M: lbf-ft

Y axis	DEAD	LIVE	LIVE ROOF	SNOW	WIND +	WIND -	SEISMIC +	SEISMIC -	ICE	RAIN	EARTH
A	502	0	643	804	0	0	0	0	0	0	0
B	502	0	643	804	0	0	0	0	0	0	0

Reaction Location

A

B

LOAD LIST

Type	Left Magnitude	Right Magnitude	Load Start (ft)	Load End (ft)	Load Type	Direction
Self Weight (lbf/ft)	5.79	5.79	0	6.667	Dead	Y

LINKED LOAD LIST

Type	Left Magnitude	Right Magnitude	Load Start (ft)	Load End (ft)	Load Type	Direction
Uniform (lbf/ft)	144.7318	144.7318	0	6.667	Dead	Y
Uniform (lbf/ft)	241.2085	241.2085	0	6.667	Snow	Y
Uniform (lbf/ft)	192.8923	192.8923	0	6.667	Roof Live	Y

DATE:	10/18/2021	COMPANY:	Pacific Northwest Structural Group, Inc
VITRUVIUS BUILD:	Base	DESIGNED BY:	David Starkel
CUSTOMER:		REVIEWED BY:	David Starkel
PROJ. ADDRESS:	-- --	PROJECT NAME:	21-028 Framing
LEVEL:	S2.3	LOADING:	ASD
MEMBER NAME:	RB7-2.3	CODE:	2018 International Building Code
MEMBER TYPE:	ROOF BEAM	NDS:	2018 NDS
MATERIAL:	Glulams		
Stress Class Rated 24F-1.8E	24F-V4 DF/DF	(1) 3.5 X 9	DRY

RB7-2.3 DIAGRAM



BEAM PROPERTIES

Start (ft): 0 End (ft): 11.333 Member Slope: 0/12 Actual Length (ft): 11.33 Roof Pitch: 0/12

Area	Ix	Iy	BSW	Lams	G	Kcr
(in ²)	(in ⁴)	(in ⁴)	(lbf/ft)			Creep Factor
31.5	212.62	32.16	7.18	1	0.5	1

STRENGTH PROPERTIES

	Fbx+	Fbx-	Fby	Ft	Fvx	Fvy	Fc	Fc _⊥	Ex	Exmin	Ey	Eymin
	(psi)	(psi)	(psi)	(psi)	(psi)	(psi)	(psi)	(psi)	(psi)	(psi)	(psi)	(psi)
Base Values	2400	1850	1450	1100	265	230	1650	650	1800000	950000	1600000	850000
Adjusted Values	2400	1850	1497	1100	265	230	1650	650	1800000	950000	1600000	850000
C _M	1	1	1	1	1	1	1	1	1	1	1	1
C _T	1	1	1	1	1	1	1	1	1	1	1	1
Bending Adjustment Factors	C _{VR} = 1											

BEAM DATA

Span	Length (ft)	Unbraced Length (ft)		Beam End				
		Top	Bottom	Elev. Diff (ft)	CL(Top)	CL(Bottom)	CL(Left)	CL(Right)
1	6.1667	0	6.1667	0	1.00	1.00	1.00	1.00
2	5.1667	0	5.1667	0	1.00	1.00	1.00	1.00

PASS-FAIL

	PASS/FAIL	MAGNITUDE	STRENGTH	LOCATION (ft)	LOAD COMBO	DURATION FACTOR CD
Shear Stress Y (psi)	PASS (75.7%)	80.6	331.3	6.12	D+Lr	1.25
Bending Stress Y (psi)	PASS (52.9%)	1083.7	2302.2	6.12	D+Lr	1.25
Deflection (in)	PASS (94.6%)	0.022 (=L/3364)	0.411 (=L/180)	4.19	D+Lr	
Bearing Stress (psi)	PASS (74.6%)	176.2	694.3	6.17	D+Lr	1.25

REACTIONS

Units for V: lbf Units for M: lbf-ft

Y axis	DEAD	LIVE	LIVE ROOF	SNOW	WIND +	WIND -	SEISMIC +	SEISMIC -	ICE	RAIN	EARTH
A	132	0	167	105	0	0	0	0	0	0	0
B	1496	0	1895	1184	0	0	0	0	0	0	0
C	0	0	0	0	0	0	0	0	0	0	0

Reaction Location

A

B

C

LOAD LIST

Type	Left Magnitude	Right Magnitude	Load Start (ft)	Load End (ft)	Load Type	Direction
Self Weight (lbf/ft)	7.18	7.18	0	11.3334	Dead	Y

LINKED LOAD LIST

Type	Left Magnitude	Right Magnitude	Load Start (ft)	Load End (ft)	Load Type	Direction
Uniform (lbf/ft)	136.4788	136.4788	0	11.3334	Dead	Y
Uniform (lbf/ft)	113.7323	113.7323	0	11.3334	Snow	Y
Uniform (lbf/ft)	181.9581	181.9581	0	11.3334	Roof Live	Y

DATE:	10/18/2021	COMPANY:	Pacific Northwest Structural Group, Inc
VITRUVIUS BUILD:	Base	DESIGNED BY:	David Starkel
CUSTOMER:		REVIEWED BY:	David Starkel
PROJ. ADDRESS:	-- --	PROJECT NAME:	21-028 Framing
LEVEL:	S2.3	LOADING:	ASD
MEMBER NAME:	RB8-2.3	CODE:	2018 International Building Code
MEMBER TYPE:	ROOF BEAM	NDS:	2018 NDS
MATERIAL:	Glulams		
Stress Class Rated 24F-1.8E	24F-V4 DF/DF	(1) 3.5 X 9	DRY

RB8-2.3 DIAGRAM



BEAM PROPERTIES

Start (ft): 0 End (ft): 15.167 Member Slope: 0/12 Actual Length (ft): 15.17 Roof Pitch: 0/12

Area	Ix	Iy	BSW	Lams	G	Kcr
(in ²)	(in ⁴)	(in ⁴)	(lbf/ft)			Creep Factor
31.5	212.62	32.16	7.18	1	0.5	1

STRENGTH PROPERTIES

	Fbx+	Fbx-	Fby	Ft	Fvx	Fvy	Fc	Fc⊥	Ex	Exmin	Ey	Eymin
	(psi)	(psi)	(psi)	(psi)	(psi)	(psi)	(psi)	(psi)	(psi)	(psi)	(psi)	(psi)
Base Values	2400	1850	1450	1100	265	230	1650	650	1800000	950000	1600000	850000
Adjusted Values	2400	1850	1497	1100	265	230	1650	650	1800000	950000	1600000	850000
C _M	1	1	1	1	1	1	1	1	1	1	1	1
C _T	1	1	1	1	1	1	1	1	1	1	1	1
Bending Adjustment Factors	C _{VR} = 1											

BEAM DATA

Span	Length (ft)	Unbraced Length (ft)		Beam End				
		Top	Bottom	Elev. Diff (ft)	CL(Top)	CL(Bottom)	CL(Left)	CL(Right)
1	10	0	10	0	1.00	0.99	1.00	1.00
2	5.1667	0	5.1667	0	1.00	1.00	1.00	1.00

PASS-FAIL

	PASS/FAIL	MAGNITUDE	STRENGTH	LOCATION (ft)	LOAD COMBO	DURATION FACTOR CD
Shear Stress Y (psi)	PASS (57.2%)	141.9	331.3	9.86	D+Lr	1.25
Bending Stress Y (psi)	PASS (29.4%)	1624.4	2302.2	10.01	D+Lr	1.15
Shear Stress X (psi)	PASS (99.9%)	0.3	264.5	9.86	D+S	1.25
Bending Stress X (psi)	PASS (99.5%)	8.1	1720.9	10.01	D+S	1.15
Deflection (in)	PASS (67.3%)	0.225 (=L/550)	0.689 (=L/180)	15.17	D+Lr	
Bearing Stress (psi)	PASS (37.2%)	451.7	719.6	10	D+Lr	1.25

REACTIONS		Units for V: lbf		Units for M: lbf-ft								
Y axis	DEAD	LIVE	LIVE ROOF	SNOW	WIND +	WIND -	SEISMIC +	SEISMIC -	ICE	RAIN	EARTH	
A	771	0	993	621	0	0	0	0	0	0	0	
B	2419	0	3115	1947	0	0	0	0	0	0	0	
C	0	0	0	0	0	0	0	0	0	0	0	
X axis												
A	-1	0	-1	-2	0	0	0	0	0	0	0	
B	-4	0	-3	-7	0	0	0	0	0	0	0	
C	0	0	0	0	0	0	0	0	0	0	0	

Reaction Location

A B C

LOAD LIST		Left Magnitude	Right Magnitude	Load Start (ft)	Load End (ft)	Load Type	Direction
Type							
Self Weight (lbf/ft)		7.18	7.18	0	15.1667	Dead	Y

LINKED LOAD LIST		Left Magnitude	Right Magnitude	Load Start (ft)	Load End (ft)	Load Type	Direction
Type							
Uniform (lbf/ft)		0.3275461	0.3275461	0	15.1667	Dead	X
Uniform (lbf/ft)		203.1002	203.1002	0	15.1667	Dead	Y
Uniform (lbf/ft)		0.6063387	0.6063387	0	15.1667	Snow	X
Uniform (lbf/ft)		169.3124	169.3124	0	15.1667	Snow	Y
Uniform (lbf/ft)		0.2700491	0.2700491	0	15.1667	Roof Live	X
Uniform (lbf/ft)		270.8003	270.8003	0	15.1667	Roof Live	Y

DATE:	10/18/2021	COMPANY:	Pacific Northwest Structural Group, Inc
VITRUVIUS BUILD:	Base	DESIGNED BY:	David Starkel
CUSTOMER:		REVIEWED BY:	David Starkel
PROJ. ADDRESS:	--	PROJECT NAME:	21-028 Framing
	--		
LEVEL:	S2.3	LOADING:	ASD
MEMBER NAME:	RB9-2.3	CODE:	2018 International Building Code
MEMBER TYPE:	ROOF BEAM	NDS:	2018 NDS
MATERIAL:	Glulams		
Stress Class Rated 24F-1.8E	24F-V4 DF/DF	(1) 3.5 X 9	DRY

RB9-2.3 DIAGRAM



BEAM PROPERTIES

Start (ft): 0 End (ft): 14.834 Member Slope: 0/12 Actual Length (ft): 14.83 Roof Pitch: 0/12

Area	Ix	Iy	BSW	Lams	G	Kcr
(in ²)	(in ⁴)	(in ⁴)	(lbf/ft)			Creep Factor
31.5	212.62	32.16	7.18	1	0.5	1

STRENGTH PROPERTIES

	Fbx+	Fbx-	Fby	Ft	Fvx	Fvy	Fc	Fc⊥	Ex	Exmin	Ey	Eymin
	(psi)	(psi)	(psi)	(psi)	(psi)	(psi)	(psi)	(psi)	(psi)	(psi)	(psi)	(psi)
Base Values	2400	1850	1450	1100	265	230	1650	650	1800000	950000	1600000	850000
Adjusted Values	2400	1850	1497	1100	265	230	1650	650	1800000	950000	1600000	850000
C _M	1	1	1	1	1	1	1	1	1	1	1	1
C _T	1	1	1	1	1	1	1	1	1	1	1	1
Bending Adjustment Factors	C _{VR} = 1											

BEAM DATA

Span	Length (ft)	Unbraced Length (ft)		Beam End				
		Top	Bottom	Elev. Diff (ft)	CL(Top)	CL(Bottom)	CL(Left)	CL(Right)
1	9.667	0	9.667	0	1.00	0.99	1.00	1.00
2	5.1667	0	5.1667	0	1.00	1.00	1.00	1.00

PASS-FAIL

	PASS/FAIL	MAGNITUDE	STRENGTH	LOCATION (ft)	LOAD COMBO	DURATION FACTOR CD
Shear Stress Y (psi)	PASS (47.3%)	174.6	331.3	9.64	D+Lr	1.25
Bending Stress Y (psi)	PASS (13.4%)	1984.7	2291.1	9.64	D+Lr	1.25
Shear Stress X (psi)	PASS (100.0%)	0.1	287.5	9.64	D+Lr	1.25
Bending Stress X (psi)	PASS (99.8%)	3.0	1870.4	9.64	D+Lr	1.25
Deflection (in)	PASS (54.6%)	0.313 (=L/397)	0.689 (=L/180)	14.83	D+Lr	
Bearing Stress (psi)	PASS (23.5%)	550.4	719.6	9.67	D+Lr	1.25

REACTIONS		Units for V: lbf		Units for M: lbf-ft								
Y axis	DEAD	LIVE	LIVE ROOF	SNOW	WIND +	WIND -	SEISMIC +	SEISMIC -	ICE	RAIN	EARTH	
A	891	0	1155	722	0	0	0	0	0	0	0	
B	2936	0	3806	2378	0	0	0	0	0	0	0	
C	0	0	0	0	0	0	0	0	0	0	0	
X axis												
A	1	0	1	0	0	0	0	0	0	0	0	
B	2	0	2	0	0	0	0	0	0	0	0	
C	0	0	0	0	0	0	0	0	0	0	0	

Reaction Location

A B C

LOAD LIST		Left Magnitude		Right Magnitude		Load Start (ft)		Load End (ft)		Load Type		Direction	
Self Weight (lbf/ft)		7.18		7.18		0		14.8337		Dead		Y	

LINKED LOAD LIST		Left Magnitude		Right Magnitude		Load Start (ft)		Load End (ft)		Load Type		Direction	
Uniform (lbf/ft)		-0.1481476		-0.1481476		0		14.8337		Dead		X	
Uniform (lbf/ft)		250.8287		250.8287		0		14.8337		Dead		Y	
Uniform (lbf/ft)		208.9823		208.9823		0		14.8337		Snow		Y	
Uniform (lbf/ft)		-0.1975431		-0.1975431		0		14.8337		Roof Live		X	
Uniform (lbf/ft)		334.3967		334.3967		0		14.8337		Roof Live		Y	

DATE:	10/18/2021	COMPANY:	Pacific Northwest Structural Group, Inc
VITRUVIUS BUILD:	Base	DESIGNED BY:	David Starkel
CUSTOMER:		REVIEWED BY:	David Starkel
PROJ. ADDRESS:	-- --	PROJECT NAME:	21-028 Framing
LEVEL:	S2.3	LOADING:	ASD
MEMBER NAME:	RB11-2.3	CODE:	2018 International Building Code
MEMBER TYPE:	ROOF BEAM	NDS:	2018 NDS
MATERIAL:	Glulams		
Stress Class Rated 24F-1.8E	24F-V4 DF/DF	(1) 3.5 X 11.875	DRY

RB11-2.3 DIAGRAM



BEAM PROPERTIES

Start (ft): 0 End (ft): 18.5 Member Slope: 0/12 Actual Length (ft): 18.5 Roof Pitch: 0/12

Area	Ix	Iy	BSW	Lams	G	Kcr
(in ²)	(in ⁴)	(in ⁴)	(lbf/ft)			Creep Factor
41.56	488.41	42.43	9.48	1	0.5	1

STRENGTH PROPERTIES

	Fbx+	Fbx-	Fby	Ft	Fvx	Fvy	Fc	Fc _⊥	Ex	Exmin	Ey	Eymin
	(psi)	(psi)	(psi)	(psi)	(psi)	(psi)	(psi)	(psi)	(psi)	(psi)	(psi)	(psi)
Base Values	2400	1850	1450	1100	265	230	1650	650	1800000	950000	1600000	850000
Adjusted Values	2400	1850	1452	1100	265	230	1650	650	1800000	950000	1600000	850000
C _M	1	1	1	1	1	1	1	1	1	1	1	1
C _T	1	1	1	1	1	1	1	1	1	1	1	1

Bending Adjustment Factors C_{VR} = 1

BEAM DATA

Span	Length (ft)	Unbraced Length (ft)		Beam End				
		Top	Bottom	Elev. Diff (ft)	CL(Top)	CL(Bottom)	CL(Left)	CL(Right)
1	18.5	0	18.5	0	1.00	0.91	1.00	1.00

PASS-FAIL

	PASS/FAIL	MAGNITUDE	STRENGTH	LOCATION (ft)	LOAD COMBO	DURATION FACTOR CD
Shear Stress Y (psi)	PASS (76.1%)	72.7	304.8	18.5	D+S	1.15
Bending Stress Y (psi)	PASS (53.2%)	1292.6	2760.0	9.44	D+S	1.15
Deflection (in)	PASS (53.3%)	0.576 (=L/386)	1.233 (=L/180)	9.25	D+Lr	
Bearing Stress (psi)	PASS (74.7%)	164.5	650.0	18.5	D+S	1.15

REACTIONS

Units for V: lbf Units for M: lbf-ft

Y axis	DEAD	LIVE	LIVE ROOF	SNOW	WIND +	WIND -	SEISMIC +	SEISMIC -	ICE	RAIN	EARTH
A	1121	0	555	694	0	0	0	0	0	0	0
B	1321	0	555	694	0	0	0	0	0	0	0

Reaction Location

A

B

LOAD LIST

Type	Left Magnitude	Right Magnitude	Load Start (ft)	Load End (ft)	Load Type	Direction
Uniform (lbf/ft)	60	60	0	18.5	Roof Live	Y
Uniform (lbf/ft)	75	75	0	18.5	Snow	Y
Trapezoidal (lbf/ft)	90	155	0	18.5	Dead	Y
Self Weight (lbf/ft)	9.48	9.48	0	18.5	Dead	Y

DATE:	10/18/2021	COMPANY:	Pacific Northwest Structural Group, Inc			
VITRUVIUS BUILD:	Base	DESIGNED BY:	David Starkel			
CUSTOMER:		REVIEWED BY:	David Starkel			
PROJ. ADDRESS:	--	PROJECT NAME:	21-028 Framing			
	--					
LEVEL:	S2.3	LOADING:	ASD			
MEMBER NAME:	RR1-2.3	CODE:	2018 International Building Code			
MEMBER TYPE:	ROOF RAFTER	NDS:	2018 NDS			
MATERIAL:	I-Joists					
Weyerhaeuser	TJI 360	(1) 11.875	16(in) O.C.	DRY		

RR1-2.3 DIAGRAM



BEAM PROPERTIES

Start (ft): 0 End (ft): 28.251 Member Slope: 2/12 Actual Length (ft): 28.64 Roof Pitch: 2/12 O.C. Spacing(in): 16

El x10 ⁶	BSW	Lams	K x10 ⁶	Mcap	Vcap	End Rcap 1.75 NS	End Rcap 3.5 NS	End Rcap 1.75 WS	End Rcap 3.5 WS	Int Rcap 3.5 NS	Int Rcap 5.25 NS	Int Rcap 3.5 WS	Int Rcap 5.25 WS
(lbf-in ²)	(lbf/ft)		(lbf)	(lbf-ft)	(lbf)	(lbf)	(lbf)	(lbf)	(lbf)	(lbf)	(lbf)	(lbf)	(lbf)
419	0	1	4.5	6180	1705	1080	1505	1440	1705	2460	3000	2815	3360

BEAM DATA

Span	Length (ft)	Unbraced Length (ft)		Beam End
		Top	Bottom	Elev. Diff (ft)
1	1.334	0	1.334	0.2223333
2	24.25	0	24.25	4.041667
3	2.667	0	2.667	0.4445

PASS-FAIL

	PASS/FAIL	MAGNITUDE	STRENGTH	LOCATION (ft)	LOAD COMBO	DURATION FACTOR CD
Shear Force (lbf)	PASS (67.1%)	644.3	1960.8	25.43	D+S	1.15
Bending Moment (lbf-ft)	PASS (45.8%)	3854.0	7107.0	13.28	D+S	1.15
Deflection (in)	PASS (15.3%)	0.153 (=L/213)	0.180 (=L/180)	0	D+Lr	
Bearing Load (lbf)	PASS (71.5%)	805.1	2829.0	25.58	D+S	1.15

REACTIONS

Units for V: lbf Units for M: lbf-ft

Z axis	DEAD	LIVE	LIVE ROOF	SNOW	WIND +	WIND -	SEISMIC +	SEISMIC -	ICE	RAIN	EARTH
A	0	0	1	1	0	0	0	0	0	0	0
B	0	0	-1	-1	0	0	0	0	0	0	0
C	-1	0	-3	0	0	0	0	0	0	0	0
D	1	0	3	0	0	0	0	0	0	0	0
Y axis											
A	0	0	0	0	0	0	0	0	0	0	0
B	270	0	361	451	0	0	0	0	0	0	0
C	302	0	403	504	0	0	0	0	0	0	0
D	0	0	0	0	0	0	0	0	0	0	0

Reaction Location WS-Web Stiffener Required NSR-No Stiffener Required

A	B			C	D
NSR	NSR			NSR	NSR

LOAD LIST

Type	Left Magnitude	Right Magnitude	Load Start (ft)	Load End (ft)	Load Type	Direction
Uniform (lbf/ft ²)	20	20	0	28.251	Roof Live	Y
Uniform (lbf/ft ²)	25	25	0	28.251	Snow	Y
Uniform (lbf/ft ²)	15	15	0	28.251	Dead	Y

DATE:	10/18/2021	COMPANY:	Pacific Northwest Structural Group, Inc		
VITRUVIUS BUILD:	Base	DESIGNED BY:	David Starkel		
CUSTOMER:	--	REVIEWED BY:	David Starkel		
PROJ. ADDRESS:	--	PROJECT NAME:	21-028 Framing		
LEVEL:	S2.2	LOADING:	ASD		
MEMBER NAME:	RR1-2.2	CODE:	2018 International Building Code		
MEMBER TYPE:	ROOF RAFTER	NDS:	2018 NDS		
MATERIAL:	Solid Sawn				
Douglas Fir-Larch	No. 2	(1) 1.5 X 11.25	16(in) O.C.	DRY	

RR1-2.2 DIAGRAM



BEAM PROPERTIES

Start (ft): 0 End (ft): 8.083 Member Slope: 4/12 Actual Length (ft): 8.52 Roof Pitch: 4/12 O.C. Spacing(in): 16

Area	Ix	Iy	BSW	Lams	G	Kcr
(in ²)	(in ⁴)	(in ⁴)	(lbf/ft)			Creep Factor
16.88	177.98	3.16	3.85	1	0.5	1

STRENGTH PROPERTIES

	Fb (psi)	Ft (psi)	Fv (psi)	Fc (psi)	Fc⊥ (psi)	E (psi) x10 ³	Emin (psi) x10 ³
Base Values	900	575	180	1350	625	1600	580
Adjusted Values	1035	575	180	1350	625	1600	580
C _M	1	1	1	1	1	1	1
C _T	1	1	1	1	1	1	1
C _i	1	1	1	1	1	1	1
C _F	1	1	1	1	1	1	1

Bending Adjustment Factors C_{fu} = 1 C_r = 1.15

BEAM DATA

Span	Length (ft)	Unbraced Length (ft)		Beam End				
		Top	Bottom	Elev. Diff (ft)	CL(Top)	CL(Bottom)	CL(Left)	CL(Right)
1	7.6667	0	7.6667	2.555567	1.00	0.70	1.00	1.00
2	0.4166713	0	0.416671	0.1388904	1.00	1.00	1.00	1.00

PASS-FAIL

	PASS/FAIL	MAGNITUDE	STRENGTH	LOCATION (ft)	LOAD COMBO	DURATION FACTOR CD
Shear Stress Y (psi)	PASS (90.6%)	19.4	207.0	0	D+S	1.15
Bending Stress Y (psi)	PASS (86.0%)	167.0	1190.2	3.8	D+S	1.15
Deflection (in)	PASS (95.3%)	0.003 (=L/3767)	0.059 (=L/180)	8.08	D+Lr	
Compressive Stress (psi)	PASS (99.7%)	4.3	1505.4	0	D+S	1.15
Tensile Stress (psi)	PASS (99.4%)	4.3	661.3	7.6	D+S	1.15
Bearing Stress (psi)	PASS (93.6%)	44.0	692.0	7.67	D+S	1.15
Bending-Compression (Unit)	PASS (86.0%)	0.14	1.00	3.8	D+S	1.15
Bending-Tension (Unit)	PASS (86.0%)	0.14	1.00	3.88	D+S	1.15

REACTIONS											
Y axis	DEAD	LIVE	LIVE ROOF	SNOW	WIND +	WIND -	SEISMIC +	SEISMIC -	ICE	RAIN	EARTH
A	96	0	107	134	0	0	0	0	0	0	0
B	107	0	120	150	0	0	0	0	0	0	0
C	0	0	0	0	0	0	0	0	0	0	0

Reaction Location

A	B	C
---	---	---

LOAD LIST							
Type	Left Magnitude	Right Magnitude	Load Start (ft)	Load End (ft)	Load Type	Direction	
Uniform (lb/ft ²)	25	25	0	8.083371	Snow	Y	
Uniform (lb/ft ²)	15	15	0	8.083371	Dead	Y	
Uniform (lb/ft ²)	20	20	0	8.083371	Roof Live	Y	
Self Weight (lb/ft)	3.85	3.85	0	8.083371	Dead	Y	

DATE:	10/18/2021	COMPANY:	Pacific Northwest Structural Group, Inc			
VITRUVIUS BUILD:	Base	DESIGNED BY:	David Starkel			
CUSTOMER:		REVIEWED BY:	David Starkel			
PROJ. ADDRESS:	--	PROJECT NAME:	21-028 Framing			
	--					
LEVEL:	S2.3	LOADING:	ASD			
MEMBER NAME:	RR2-2.3	CODE:	2018 International Building Code			
MEMBER TYPE:	ROOF RAFTER	NDS:	2018 NDS			
MATERIAL:	I-Joists					
Weyerhaeuser	TJI 210	(1) 11.875	24(in) O.C.	DRY		

RR2-2.3 DIAGRAM



BEAM PROPERTIES

Start (ft): 0 End (ft): 18.583 Member Slope: 2/12 Actual Length (ft): 18.84 Roof Pitch: 2/12 O.C. Spacing(in): 24

El x10 ⁶	BSW	Lams	K x10 ⁶	Mcap	Vcap	End Rcap 1.75 NS	End Rcap 3.5 NS	End Rcap 1.75 WS	End Rcap 3.5 WS	Int Rcap 3.5 NS	Int Rcap 5.25 NS	Int Rcap 3.5 WS	Int Rcap 5.25 WS
(lbf-in ²)	(lbf/ft)		(lbf)	(lbf-ft)	(lbf)	(lbf)	(lbf)	(lbf)	(lbf)	(lbf)	(lbf)	(lbf)	(lbf)
315	0	1	4.5	3795	1655	1005	1460	1365	1655	2145	2565	2505	2925

BEAM DATA

Span	Length (ft)	Unbraced Length (ft)		Beam End
		Top	Bottom	Elev. Diff (ft)
1	14.41667	0	14.41667	2.402778
2	4.1667	0	4.1667	0.6944501

PASS-FAIL

	PASS/FAIL	MAGNITUDE	STRENGTH	LOCATION (ft)	LOAD COMBO	DURATION FACTOR CD
Shear Force (lbf)	PASS (67.6%)	616.2	1903.3	14.31	D+S	1.15
Bending Moment (lbf-ft)	PASS (59.5%)	1769.6	4364.3	6.69	D+S	1.15
Deflection (in)	PASS (69.5%)	0.172 (=L/590)	0.563 (=L/180)	18.58	D+Lr	
Bearing Load (lbf)	PASS (67.1%)	971.6	2949.8	14.42	D+S	1.15

REACTIONS

Units for V: lbf Units for M: lbf-ft Unbalanced loads checked for Live and Live Roof loads, reactions are an "envelope" of combos

Z axis	DEAD	LIVE	LIVE ROOF	SNOW	WIND +	WIND -	SEISMIC +	SEISMIC -	ICE	RAIN	EARTH
A	0	0	0 / -1	0	0	0	0	0	0	0	0
B	0	0	1 / 0	0	0	0	0	0	0	0	0
C	0	0	0	0	0	0	0	0	0	0	0
Y axis											
A	201	0	292 / -24	335	0	0	0	0	0	0	0
B	364	0	486	607	0	0	0	0	0	0	0
C	0	0	0	0	0	0	0	0	0	0	0

Reaction Location WS-Web Stiffener Required NSR-No Stiffener Required



UNBALANCED LIVE LOAD - WORST CASE

(Critical Condition Does Not Include Live Loads)



LOAD LIST

Type	Left Magnitude	Right Magnitude	Load Start (ft)	Load End (ft)	Load Type	Direction
Uniform (lbf/ft ²)	20	20	0	18.58337	Roof Live	Y
Uniform (lbf/ft ²)	25	25	0	18.58337	Snow	Y
Uniform (lbf/ft ²)	15	15	0	18.58337	Dead	Y

DATE:	10/18/2021	COMPANY:	Pacific Northwest Structural Group, Inc	
VITRUVIUS BUILD:	Base	DESIGNED BY:	David Starkel	
CUSTOMER:		REVIEWED BY:	David Starkel	
PROJ. ADDRESS:	-- --	PROJECT NAME:	21-028 Framing	
LEVEL:	S2.3	LOADING:	ASD	
MEMBER NAME:	RR3-2.3	CODE:	2018 International Building Code	
MEMBER TYPE:	ROOF RAFTER	NDS:	2018 NDS	
MATERIAL:	I-Joists			
Weyerhaeuser	TJI 210	(1) 11.875	24(in) O.C.	DRY

RR3-2.3 DIAGRAM



BEAM PROPERTIES

Start (ft): 0 End (ft): 22.667 Member Slope: 2/12 Actual Length (ft): 22.98 Roof Pitch: 2/12 O.C. Spacing(in): 24

El x10 ⁶ (lbf-in ²)	BSW (lbf/ft)	Lams	K x10 ⁶ (lbf)	Mcap (lbf-ft)	Vcap (lbf)	End Rcap 1.75 NS (lbf)	End Rcap 3.5 NS (lbf)	End Rcap 1.75 WS (lbf)	End Rcap 3.5 WS (lbf)	Int Rcap 3.5 NS (lbf)	Int Rcap 5.25 NS (lbf)	Int Rcap 3.5 WS (lbf)	Int Rcap 5.25 WS (lbf)
315	0	1	4.5	3795	1655	1005	1460	1365	1655	2145	2565	2505	2925

BEAM DATA

Span	Length (ft)	Unbraced Length (ft)		Beam End
		Top	Bottom	Elev. Diff (ft)
1	18.8334	0	18.8334	3.138901
2	3.833399	0	3.8334	0.6388999

PASS-FAIL

	PASS/FAIL	MAGNITUDE	STRENGTH	LOCATION (ft)	LOAD COMBO	DURATION FACTOR CD
Shear Force (lbf)	PASS (58.9%)	782.9	1903.3	18.81	D+S	1.15
Bending Moment (lbf-ft)	PASS (24.3%)	3304.1	4364.3	9.07	D+S	1.15
Deflection (in)	PASS (50.7%)	0.628 (=L/365)	1.273 (=L/180)	9.29	D+Lr	
Bearing Load (lbf)	PASS (56.4%)	732.2	1679.0	0	D+S	1.15

REACTIONS

Units for V: lbf Units for M: lbf-ft Unbalanced loads checked for Live and Live Roof loads, reactions are an "envelope" of combos

Y axis	DEAD	LIVE	LIVE ROOF	SNOW	WIND +	WIND -	SEISMIC +	SEISMIC -	ICE	RAIN	EARTH
A	275	0	382 / -16	458	0	0	0	0	0	0	0
B	415	0	553	691	0	0	0	0	0	0	0
C	0	0	0	0	0	0	0	0	0	0	0

Reaction Location WS-Web Stiffener Required NSR-No Stiffener Required



UNBALANCED LIVE LOAD - WORST CASE

(Critical Condition Does Not Include Live Loads)



LOAD LIST

Type	Left Magnitude	Right Magnitude	Load Start (ft)	Load End (ft)	Load Type	Direction
Uniform (lbf/ft ²)	20	20	0	22.6668	Roof Live	Y
Uniform (lbf/ft ²)	25	25	0	22.6668	Snow	Y
Uniform (lbf/ft ²)	15	15	0	22.6668	Dead	Y

DATE:	10/18/2021	COMPANY:	Pacific Northwest Structural Group, Inc			
VITRUVIUS BUILD:	Base	DESIGNED BY:	David Starkel			
CUSTOMER:		REVIEWED BY:	David Starkel			
PROJ. ADDRESS:	--	PROJECT NAME:	21-028 Framing			
	--					
LEVEL:	S2.3	LOADING:	ASD			
MEMBER NAME:	RR4-2.3	CODE:	2018 International Building Code			
MEMBER TYPE:	ROOF RAFTER	NDS:	2018 NDS			
MATERIAL:	I-Joists					
Weyerhaeuser	TJI 210	(1) 11.875	24(in) O.C.	DRY		

RR4-2.3 DIAGRAM



BEAM PROPERTIES

Start (ft): 0 End (ft): 17.083 Member Slope: 2/12 Actual Length (ft): 17.32 Roof Pitch: 2/12 O.C. Spacing(in): 24

El x10 ⁶ (lbf-in ²)	BSW (lbf/ft)	Lams	K x10 ⁶ (lbf)	Mcap (lbf-ft)	Vcap (lbf)	End Rcap 1.75 NS (lbf)	End Rcap 3.5 NS (lbf)	End Rcap 1.75 WS (lbf)	End Rcap 3.5 WS (lbf)	Int Rcap 3.5 NS (lbf)	Int Rcap 5.25 NS (lbf)	Int Rcap 3.5 WS (lbf)	Int Rcap 5.25 WS (lbf)
315	0	1	4.5	3795	1655	1005	1460	1365	1655	2145	2565	2505	2925

BEAM DATA

Span	Length (ft)	Unbraced Length (ft)		Beam End
		Top	Bottom	Elev. Diff (ft)
1	15.3334	0	15.3334	2.555567
2	1.750001	0	1.75	0.2916668

PASS-FAIL

	PASS/FAIL	MAGNITUDE	STRENGTH	LOCATION (ft)	LOAD COMBO	DURATION FACTOR CD
Shear Force (lbf)	PASS (67.9%)	611.0	1903.3	15.2	D+S	1.15
Bending Moment (lbf-ft)	PASS (46.8%)	2322.1	4364.3	7.52	D+S	1.15
Deflection (in)	PASS (72.6%)	0.284 (=L/656)	1.036 (=L/180)	7.69	D+Lr	
Bearing Load (lbf)	PASS (63.4%)	613.7	1679.0	0	D+S	1.15

REACTIONS

Units for V: lbf Units for M: lbf-ft Unbalanced loads checked for Live and Live Roof loads, reactions are an "envelope" of combos

Y axis	DEAD	LIVE	LIVE ROOF	SNOW	WIND +	WIND -	SEISMIC +	SEISMIC -	ICE	RAIN	EARTH
A	230	0	311 / -4	384	0	0	0	0	0	0	0
B	289	0	386	482	0	0	0	0	0	0	0
C	0	0	0	0	0	0	0	0	0	0	0

Reaction Location WS-Web Stiffener Required NSR-No Stiffener Required



UNBALANCED LIVE LOAD - WORST CASE

(Critical Condition Does Not Include Live Loads)



LOAD LIST

Type	Left Magnitude	Right Magnitude	Load Start (ft)	Load End (ft)	Load Type	Direction
Uniform (lbf/ft ²)	20	20	0	17.0834	Roof Live	Y
Uniform (lbf/ft ²)	25	25	0	17.0834	Snow	Y
Uniform (lbf/ft ²)	15	15	0	17.0834	Dead	Y

DATE:	10/18/2021	COMPANY:	Pacific Northwest Structural Group, Inc	
VITRUVIUS BUILD:	Base	DESIGNED BY:	David Starkel	
CUSTOMER:		REVIEWED BY:	David Starkel	
PROJ. ADDRESS:	-- --	PROJECT NAME:	21-028 Framing	
LEVEL:	S2.3	LOADING:	ASD	
MEMBER NAME:	RR5-2.3	CODE:	2018 International Building Code	
MEMBER TYPE:	ROOF RAFTER	NDS:	2018 NDS	
MATERIAL:	I-Joists			
Weyerhaeuser	TJI 210	(1) 11.875	24(in) O.C.	DRY

RR5-2.3 DIAGRAM



BEAM PROPERTIES

Start (ft): 0 End (ft): 22.334 Member Slope: 2/12 Actual Length (ft): 22.64 Roof Pitch: 2/12 O.C. Spacing(in): 24

El x10 ⁶	BSW	Lams	K x10 ⁶	Mcap	Vcap	End Rcap	End Rcap	End Rcap	End Rcap	Int Rcap	Int Rcap	Int Rcap	Int Rcap
(lb-in ²)	(lb-ft)		(lb)	(lb-ft)	(lb)	1.75 NS	3.5 NS	1.75 WS	3.5 WS	3.5 NS	5.25 NS	3.5 WS	5.25 WS
315	0	1	4.5	3795	1655	1005	1460	1365	1655	2145	2565	2505	2925

BEAM DATA

Span	Length (ft)	Unbraced Length (ft)		Beam End
		Top	Bottom	Elev. Diff (ft)
1	18.667	0	18.667	3.111167
2	3.667	0	3.667	0.6111667

PASS-FAIL

	PASS/FAIL	MAGNITUDE	STRENGTH	LOCATION (ft)	LOAD COMBO	DURATION FACTOR CD
Shear Force (lbf)	PASS (67.6%)	669.4	2068.8	18.54	D+Lr	1.25
Bending Moment (lb-ft)	PASS (39.7%)	2858.1	4743.8	8.93	D+Lr	1.25
Deflection (in)	PASS (33.9%)	0.328 (=L/272)	0.496 (=L/180)	22.33	D+Lr	
Bearing Load (lbf)	PASS (64.6%)	948.1	2681.3	18.67	D+Lr	1.25

REACTIONS

Units for V: lbf Units for M: lbf-ft

Z axis	DEAD	LIVE	LIVE ROOF	SNOW	WIND +	WIND -	SEISMIC +	SEISMIC -	ICE	RAIN	EARTH
A	0	0	0	0	0	0	0	0	0	0	0
B	1	0	1	1	0	0	0	0	0	0	0
C	-1	0	-1	-1	0	0	0	0	0	0	0
Y axis											
A	273	0	364	227	0	0	0	0	0	0	0
B	406	0	542	339	0	0	0	0	0	0	0
C	0	0	0	0	0	0	0	0	0	0	0

Reaction Location WS-Web Stiffener Required NSR-No Stiffener Required

A		B	C
NSR		NSR	NSR

LOAD LIST

Type	Left Magnitude	Right Magnitude	Load Start (ft)	Load End (ft)	Load Type	Direction
Uniform (lb/ft ²)	20	20	0	22.334	Roof Live	Y
Uniform (lb/ft)	25	25	0	22.334	Snow	Y
Uniform (lb/ft ²)	15	15	0	22.334	Dead	Y

DATE:	10/18/2021	COMPANY:	Pacific Northwest Structural Group, Inc	
VITRUVIUS BUILD:	Base	DESIGNED BY:	David Starkel	
CUSTOMER:		REVIEWED BY:	David Starkel	
PROJ. ADDRESS:	-- --	PROJECT NAME:	21-028 Framing	
LEVEL:	S2.3	LOADING:	ASD	
MEMBER NAME:	RR6-2.3	CODE:	2018 International Building Code	
MEMBER TYPE:	ROOF RAFTER	NDS:	2018 NDS	
MATERIAL:	I-Joists			
Weyerhaeuser	TJI 210	(1) 11.875	24(in) O.C.	DRY

RR6-2.3 DIAGRAM



BEAM PROPERTIES

Start (ft): 0 End (ft): 26 Member Slope: 2/12 Actual Length (ft): 26.36 Roof Pitch: 2/12 O.C. Spacing(in): 24

El x10 ⁶	BSW	Lams	K x10 ⁶	Mcap	Vcap	End Rcap 1.75 NS	End Rcap 3.5 NS	End Rcap 1.75 WS	End Rcap 3.5 WS	Int Rcap 3.5 NS	Int Rcap 5.25 NS	Int Rcap 3.5 WS	Int Rcap 5.25 WS
(lbf-in ²)	(lbf/ft)		(lbf)	(lbf-ft)	(lbf)	(lbf)	(lbf)	(lbf)	(lbf)	(lbf)	(lbf)	(lbf)	(lbf)
315	0	1	4.5	3795	1655	1005	1460	1365	1655	2145	2565	2505	2925

BEAM DATA

Span	Length (ft)	Unbraced Length (ft)		Beam End
		Top	Bottom	Elev. Diff (ft)
1	20.5	0	20.5	3.416667
2	5.5	0	5.5	0.9166667

PASS-FAIL

	PASS/FAIL	MAGNITUDE	STRENGTH	LOCATION (ft)	LOAD COMBO	DURATION FACTOR CD
Shear Force (lbf)	PASS (63.6%)	753.9	2068.8	20.28	D+Lr	1.25
Bending Moment (lbf-ft)	PASS (32.4%)	3208.8	4743.8	9.62	D+Lr	1.25
Deflection (in)	PASS (30.6%)	0.516 (=L/259)	0.743 (=L/180)	26	D+Lr	
Bearing Load (lbf)	PASS (56.3%)	1170.5	2681.3	20.5	D+Lr	1.25

REACTIONS

Units for V: lbf Units for M: lbf-ft

Z axis	DEAD	LIVE	LIVE ROOF	SNOW	WIND +	WIND -	SEISMIC +	SEISMIC -	ICE	RAIN	EARTH
A	-1	0	-2	-1	0	0	0	0	0	0	0
B	0	0	0	0	0	0	0	0	0	0	0
C	1	0	2	1	0	0	0	0	0	0	0
Y axis											
A	289	0	385	241	0	0	0	0	0	0	0
B	502	0	669	418	0	0	0	0	0	0	0
C	0	0	0	0	0	0	0	0	0	0	0

Reaction Location WS-Web Stiffener Required NSR-No Stiffener Required

A		B	C
NSR		NSR	NSR

LOAD LIST

Type	Left Magnitude	Right Magnitude	Load Start (ft)	Load End (ft)	Load Type	Direction
Uniform (lbf/ft ²)	20	20	0	26	Roof Live	Y
Uniform (lbf/ft)	25	25	0	26	Snow	Y
Uniform (lbf/ft ²)	15	15	0	26	Dead	Y

DATE:	10/18/2021	COMPANY:	Pacific Northwest Structural Group, Inc	
VITRUVIUS BUILD:	Base	DESIGNED BY:	David Starkel	
CUSTOMER:		REVIEWED BY:	David Starkel	
PROJ. ADDRESS:	-- --	PROJECT NAME:	21-028 Framing	
LEVEL:	S2.3	LOADING:	ASD	
MEMBER NAME:	RR7-2.3	CODE:	2018 International Building Code	
MEMBER TYPE:	ROOF RAFTER	NDS:	2018 NDS	
MATERIAL:	Solid Sawn			
Douglas Fir-Larch	No. 2	(1) 1.5 X 11.25	24(in) O.C.	DRY

RR7-2.3 DIAGRAM



BEAM PROPERTIES

Start (ft): 0 End (ft): 16 Member Slope: 4/12 Actual Length (ft): 16.87 Roof Pitch: 4/12 O.C. Spacing(in): 24

Area	Ix	Iy	BSW	Lams	G	Kcr
(in ²)	(in ⁴)	(in ⁴)	(lbf/ft)			Creep Factor
16.88	177.98	3.16	3.85	1	0.5	1

STRENGTH PROPERTIES

	Fb (psi)	Ft (psi)	Fv (psi)	Fc (psi)	Fc⊥ (psi)	E (psi) x10 ³	Emin (psi) x10 ³
Base Values	900	575	180	1350	625	1600	580
Adjusted Values	1035	575	180	1350	625	1600	580
C _M	1	1	1	1	1	1	1
C _T	1	1	1	1	1	1	1
C _i	1	1	1	1	1	1	1
C _F	1	1	1	1	1	1	1

Bending Adjustment Factors C_{fu} = 1 C_r = 1.15

BEAM DATA

Span	Length (ft)	Unbraced Length (ft)		Beam End				
		Top	Bottom	Elev. Diff (ft)	CL(Top)	CL(Bottom)	CL(Left)	CL(Right)
1	16	0	16	5.333333	1.00	0.36	1.00	1.00

PASS-FAIL

	PASS/FAIL	MAGNITUDE	STRENGTH	LOCATION (ft)	LOAD COMBO	DURATION FACTOR CD
Shear Stress Y (psi)	PASS (71.2%)	59.6	207.0	0	D+S	1.15
Bending Stress Y (psi)	PASS (9.9%)	1072.7	1190.2	8	D+S	1.15
Deflection (in)	PASS (60.2%)	0.448 (=L/452)	1.124 (=L/180)	8	D+Lr	
Compressive Stress (psi)	PASS (98.8%)	13.3	1100.6	0	D+S	1.15
Tensile Stress (psi)	PASS (98.0%)	13.3	661.3	16	D+S	1.15
Bearing Stress (psi)	PASS (80.6%)	121.2	625.0	0	D+S	1.15
Bending-Compression (Unit)	PASS (9.9%)	0.90	1.00	8	D+S	1.15
Bending-Tension (Unit)	PASS (9.9%)	0.90	1.00	8.16	D+S	1.15

REACTIONS

Units for V: lbf Units for M: lbf-ft

Y axis	DEAD	LIVE	LIVE ROOF	SNOW	WIND +	WIND -	SEISMIC +	SEISMIC -	ICE	RAIN	EARTH
A	285	0	337	422	0	0	0	0	0	0	0
B	285	0	337	422	0	0	0	0	0	0	0

Reaction Location

A

B

LOAD LIST

Type	Left Magnitude	Right Magnitude	Load Start (ft)	Load End (ft)	Load Type	Direction
Uniform (lb/ft ²)	20	20	0	16	Roof Live	Y
Uniform (lb/ft ²)	25	25	0	16	Snow	Y
Uniform (lb/ft ²)	15	15	0	16	Dead	Y
Self Weight (lb/ft)	3.85	3.85	0	16	Dead	Y

Pacific Northwest Structural Group, Inc.









Project:	Smith-Cutright Residence Addition & Remodel	By:	DLS
Location:	7655 SE 40th Street, Mercer Island, WA 98040	Project No.:	21-028
Client:	Laura Smith & David Cutright	Last Update: 24-Apr-20	
AWC SDPWS-2015 - Wood Shear Wall Design Aid ALLOWABLE STRESS DESIGN			

Mark	Sheathing Type, Nail Size, Panel Edges Fastener Spacing, & Capacity	Capacity (plf)
⊠A	7/16" Sheathing W/ 8d @ 6" oc	335
⊠B	7/16" Sheathing W/ 8d @ 4" oc	490
◇	None	#N/A
◇	None	#N/A
◇	None	#N/A
◇	None	#N/A

Mark	Simpson Strong-Tie Holdowns	Capacity (lb)	Holdown Deflection at Highest Load (in)
①	HDU2-SDS2.5 W/ 3" Post	3,075	0.088
○	None	N/A	N/A
○	None	N/A	N/A
○	None	N/A	N/A
○	None	N/A	N/A
○	None	N/A	N/A
○	None	N/A	N/A
○	None	N/A	N/A
○	None	N/A	N/A
○	None	N/A	N/A
○	None	N/A	N/A

○ SEISMIC
● WIND

Shear Wall Deflection		
G	90,000	psi
E	1,200,000	psi
A	8.25	in ²

2rd Level								1st Level									
Lateral Trib. Width	ft	24.8	Shearwall Type														
V from above	k	-															
Uniform v this level	plf	105.0															
Total Wall Length	ft	29.42															
V this level	k	2.6															
V accum.	k	2.6															
Unit Wall Shear	plf	88															
Shear Wall Capacity	plf	335															
Demand vs. Capacity Ratio		0.26															
Apparent Stiffness, Ga	K/In	11.00															
Overturing Moment								Overturing Moment									
			Wall 1	Wall 2	Wall 3	Wall 4	Wall 5	Wall 6				Wall 1	Wall 2	Wall 3	Wall 4	Wall 5	Wall 6
M _{OT} from above	k-ft	-	-	-	-	-	-	-	M _{OT} from above	k-ft	7.67	2.85	10.47	-	-	-	-
Story Ht	ft	8.08	8.08	8.08	-	-	-	-	Story Ht	ft	-	8.08	8.08	8.08	8.08	8.08	8.08
Length	ft	10.75	4.00	14.67	-	-	-	-	Length	ft	-	2.42	2.17	3.00	7.67	8.50	-
Diaphragm Ratio		0.75	2.02	0.55	-	-	-	-	Diaphragm Ratio		-	3.34	3.72	2.69	1.05	0.95	-
Modified Capacity		335	332	335	-	-	-	-	Modified Capacity		-	279	N/A	306	335	335	-
M _{OT}	k-ft	7.7	2.9	10.5	-	-	-	-	M _{OT}	k-ft	-	4.7	4.2	5.8	14.9	16.5	-
M _{OT} accum	k-ft	7.7	2.9	10.5	-	-	-	-	M _{OT} accum	k-ft	7.7	7.6	14.7	5.8	14.9	16.5	-
Shear Wall Defection								Shear Wall Defection									
Δ _B	in	0.042	0.113	0.031	-	-	-	-	Δ _B	in	-	0.509	0.567	0.410	0.160	0.145	-
Δ _V	in	0.226	0.226	0.226	-	-	-	-	Δ _V	in	-	0.226	0.226	0.226	0.226	0.226	-
Δ _{HD}	in	0.066	0.178	0.048	-	-	-	-	Δ _{HD}	in	-	0.294	0.328	0.237	0.093	0.084	-
Δ _{SW}	in	0.334	0.516	0.305	-	-	-	-	Δ _{SW}	in	-	1.028	1.121	0.873	0.479	0.454	-
Resisting Moment								Resisting Moment									
M _R from above	k-ft	-	-	-	-	-	-	-	M _R from above	k-ft	8.8	1.2	16.4	-	-	-	-
Distr. Wts.	Wall Wt	psf	10.0	10.0	10.0	-	-	-	Distr. Wts.	Wall Wt	psf	10.0	10.0	10.0	10.0	10.0	10.0
	Trib above	ft	6.0	6.0	6.0	-	-	-		Trib above	ft	6.0	6.0	6.0	6.0	6.0	6.0
End Wts.	Wt above	psf	12.0	12.0	12.0	-	-	-	End Wts.	Wt above	psf	12.0	12.0	12.0	12.0	12.0	12.0
	Hdr. Trib	ft	-	-	-	-	-	-		Hdr. Trib	ft	-	-	-	#####	-	-
Perp. Wall Wts.	trib to hdr	ft	-	-	-	-	-	-	Perp. Wall Wts.	trib to hdr	ft	-	-	-	-	-	-
	Wt to hdr	psf	-	-	-	-	-	-		Wt to hdr	psf	-	-	-	-	-	-
Dist to wall	Dist to wall	ft	-	-	-	-	-	-	Dist to wall	Dist to wall	ft	-	-	-	-	-	-
	Wt of wall	lb	-	-	-	-	-	-		Wt of wall	lb	-	-	-	-	-	-
M _R this level	Dist to wall	ft	-	-	-	-	-	-	M _R this level	Dist to wall	ft	-	-	-	-	-	-
	Wt of wall	lb	-	-	-	-	-	-		Wt of wall	lb	-	-	-	-	-	-
M _R this level	k-ft	8.83	1.22	16.44	-	-	-	-	M _R this level	k-ft	-	0.45	0.36	0.69	4.49	5.52	-
M _R accum	k-ft	8.83	1.22	16.44	-	-	-	-	M _R accum	k-ft	8.83	1.67	16.80	0.69	4.49	5.52	-
Hold Down Forces								Hold Down Forces									
Wt. Reduction		0.60	0.60	0.60	0.60	0.60	0.60	0.60	Wt. Reduction		0.60	0.60	0.60	0.60	0.60	0.60	0.60
T _R accum	k	0.82	0.31	1.12	-	-	-	-	T _R accum	k	-	0.69	7.74	0.23	0.59	0.65	-
HD Offset	ft	-	-	-	-	-	-	-	HD Offset	ft	-	-	-	-	-	-	-
HD Force	k	0.22	0.53	0.04	-	-	-	-	HD Force	k	-	2.71	2.12	1.81	1.59	1.55	-
HD Capacity	k	3.08	3.08	3.08	-	-	-	-	HD Capacity	k	-	3.08	3.08	3.08	3.08	3.08	-
Hold Down Type		(I)	(I)	(I)	(-)	(-)	(-)	(-)	Hold Down Type		(-)	(I)	(I)	(I)	(I)	(I)	(I)
Project: Smith-Cutright Residence Addition & Remodel										By: DLS							
Location: TF-1										Job No.: 21-028							
Client: Laura Smith & David Cutright										Last Update: 24-Apr-20							
Wood Shear Wall Design Aid										Comments:							

1st Level Shear Wall Design Aid														
Lateral Trib. Width	ft	24.8	Shearwall Type											
V from above	k	-												
Uniform v this level	plf	105.0												
Total Wall Length	ft	22.7												
V this level	k	2.6												
V accum.	k	2.6												
Unit Wall Shear	plf	115												
Unit Shear Wall Capacity	plf	335												
Demand vs. Capacity Ratio		0.34												
Apparent Stiffness, Ga	K/In	11.00												
Overturning Moment														
Wall		Wall 1	Wall 2	Wall 3	Wall 4	Wall 5	Wall 6	Wall 7	Wall 8	Wall 9	Wall 10	Wall 11	Wall 12	
M _{OT} from above	k-ft	-	-	-	-	-	-	-	-	-	-	-	-	
Story Ht	ft	8.08	8.08	8.08	8.08	-	-	-	-	-	-	-	-	
Length	ft	4.17	10.50	4.17	3.83	-	-	-	-	-	-	-	-	
Diaphragm Ratio		1.94	0.77	1.94	2.11	-	-	-	-	-	-	-	-	
Modified Capacity		335	335	335	330	-	-	-	-	-	-	-	-	
M _{OT}	k-ft	3.9	9.7	3.9	3.5	-	-	-	-	-	-	-	-	
M _{OT} accum	k-ft	3.9	9.7	3.9	3.5	-	-	-	-	-	-	-	-	
Shear Wall Deflection														
Δ _B	in	0.141	0.056	0.141	0.153	-	-	-	-	-	-	-	-	
Δ _V	in	0.226	0.226	0.226	0.226	-	-	-	-	-	-	-	-	
Δ _{HD}	in	0.171	0.068	0.171	0.186	-	-	-	-	-	-	-	-	
Δ _{SW}	in	0.537	0.349	0.537	0.564	-	-	-	-	-	-	-	-	
Resisting Moment														
M _R from above	k-ft	-	-	-	-	-	-	-	-	-	-	-	-	
Distr. Wts.	Wall Wt	psf	10.0	10.0	10.0	10.0	-	-	-	-	-	-	-	
	Trib above	ft	6.0	6.0	6.0	6.0	-	-	-	-	-	-	-	
	Wt above	psf	12.0	12.0	12.0	12.0	-	-	-	-	-	-	-	
End Wts.	Hdr. Trib	ft	-	-	-	-	-	-	-	-	-	-	-	
	trib to hdr	ft	-	-	-	-	-	-	-	-	-	-	-	
	Wt to hdr	psf	-	-	-	-	-	-	-	-	-	-	-	
Perp. Wall Wts.	Dist to wall	ft	4.17	10.50	4.17	3.83	-	-	-	-	-	-	-	
	Wt of wall	lb	-	-	-	-	-	-	-	-	-	-	-	
	Dist to wall	ft	-	-	-	-	-	-	-	-	-	-	-	
	Wt of wall	lb	-	-	-	-	-	-	-	-	-	-	-	
M _R this level	k-ft	1.33	8.42	1.33	1.12	-	-	-	-	-	-	-	-	
M _R accum	k-ft	1.33	8.42	1.33	1.12	-	-	-	-	-	-	-	-	
Hold Down Forces														
Wt. Reduction		0.60	0.60	0.60	0.60	0.60	0.60	0.60	0.60	0.60	0.60	0.60	0.60	
T _R accum	k	0.32	0.80	0.32	0.29	-	-	-	-	-	-	-	-	
HD Offset	ft	-	-	-	-	-	-	-	-	-	-	-	-	
HD Force	k	0.74	0.44	0.74	0.75	-	-	-	-	-	-	-	-	
HD Capacity	k	3.08	3.08	3.08	3.08	-	-	-	-	-	-	-	-	
Hold Down Type		(I)	(I)	(I)	(I)	(-)	(-)	(-)	(-)	(-)	(-)	(-)	(-)	
Project:	Smith-Cutright Residence Addition & Remodel	By: DLS												
	Location:	TF-2 2nd	Job No.: 21-028											
	Client:	Laura Smith & David Cutright	Last Update: 24-Apr-20											
Wood Shear Wall Design Aid Comments:														

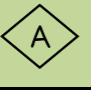
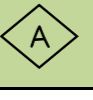
2rd Level								1st Level									
Lateral Trib. Width	ft	22.6	Shearwall Type					Lateral Trib. Width	ft	22.6	Shearwall Type						
V from above	k	-						V from above	k	2.4							
Uniform v this level	plf	105.0	Uniform v this level	plf				125.9									
Total Wall Length	ft	17.84	Total Wall Length	ft				42.67									
V this level	k	2.4	V this level	k				2.8									
V accum.	k	2.4	V accum.	k				5.2									
Unit Wall Shear	plf	133	Unit Wall Shear	plf	122												
Shear Wall Capacity	plf	335	Shear Wall Capacity	plf	335												
Demand vs. Capacity Ratio		0.40	Demand vs. Capacity Ratio		0.37												
Apparent Stiffness, Ga	K/In	11.00	Apparent Stiffness, Ga	K/In	11.00												
Overturing Moment								Overturing Moment									
			Wall 1	Wall 2	Wall 3	Wall 4	Wall 5	Wall 6				Wall 1	Wall 2	Wall 3	Wall 4	Wall 5	Wall 6
M _{OT} from above	k-ft	-	-	-	-	-	-	-	M _{OT} from above	k-ft	9.44	5.24	5.62	5.62	-	-	-
Story Ht	ft	10.50	10.50	11.50	11.50	-	-	-	Story Ht	ft	8.08	8.08	8.08	8.08	8.08	8.08	8.08
Length	ft	6.75	3.75	3.67	3.67	-	-	-	Length	ft	5.58	7.42	7.25	7.25	8.17	7.00	-
Diaphragm Ratio		1.56	2.80	3.13	3.13	-	-	-	Diaphragm Ratio		1.45	1.09	1.11	1.11	0.99	1.15	-
Modified Capacity		335	239	214	214	-	-	-	Modified Capacity		335	335	335	335	335	335	335
M _{OT}	k-ft	9.4	5.2	5.6	5.6	-	-	-	M _{OT}	k-ft	5.5	7.3	7.2	7.2	8.1	6.9	-
M _{OT} accum	k-ft	9.4	5.2	5.6	5.6	-	-	-	M _{OT} accum	k-ft	15.0	12.6	12.8	12.8	8.1	6.9	-
Shear Wall Defection								Shear Wall Defection									
Δ _B	in	0.221	0.399	0.535	0.535	-	-	-	Δ _B	in	0.112	0.084	0.086	0.086	0.077	0.089	-
Δ _V	in	0.293	0.293	0.321	0.321	-	-	-	Δ _V	in	0.226	0.226	0.226	0.226	0.226	0.226	-
Δ _{HD}	in	0.137	0.246	0.276	0.276	-	-	-	Δ _{HD}	in	0.127	0.096	0.098	0.098	0.087	0.102	-
Δ _{SW}	in	0.651	0.938	1.132	1.132	-	-	-	Δ _{SW}	in	0.465	0.406	0.410	0.410	0.389	0.417	-
Resisting Moment								Resisting Moment									
M _R from above	k-ft	-	-	-	-	-	-	-	M _R from above	k-ft	5.9	1.8	2.0	2.0	-	-	-
Distr. Wts.	Wall Wt	psf	10.0	10.0	10.0	10.0	-	-	Distr. Wts.	Wall Wt	psf	10.0	10.0	10.0	10.0	10.0	10.0
	Trib above	ft	12.7	12.7	15.8	15.8	-	-		Distr. Wts.	Trib above	ft	6.0	6.0	6.0	6.0	6.0
End Wts.	Wt above	psf	12.0	12.0	12.0	12.0	-	-	End Wts.		Wt above	psf	12.0	12.0	12.0	12.0	12.0
	Hdr. Trib	ft	-	-	-	-	-	-		End Wts.	Hdr. Trib	ft	-	#####	-	#####	-
Perp. Wall Wts.	trib to hdr	ft	-	-	-	-	-	-	Perp. Wall Wts.		trib to hdr	ft	-	-	-	-	-
	Wt to hdr	psf	-	-	-	-	-	-		Perp. Wall Wts.	Wt to hdr	psf	-	-	-	-	-
Perp. Wall Wts.	Dist to wall	ft	-	-	-	-	-	-	Perp. Wall Wts.		Dist to wall	ft	-	-	-	-	-
	Wt of wall	lb	-	-	-	-	-	-		Perp. Wall Wts.	Wt of wall	lb	-	-	-	-	-
Perp. Wall Wts.	Dist to wall	ft	-	-	-	-	-	-	Perp. Wall Wts.		Dist to wall	ft	-	-	-	-	-
	Wt of wall	lb	-	-	-	-	-	-		Perp. Wall Wts.	Wt of wall	lb	-	-	-	-	-
M _R this level	k-ft	5.86	1.81	2.05	2.05	-	-	-	M _R this level		k-ft	2.38	4.21	4.02	4.02	5.10	3.74
M _R accum	k-ft	5.86	1.81	2.05	2.05	-	-	-	M _R accum	k-ft	8.23	6.01	6.06	6.06	5.10	3.74	-
Hold Down Forces								Hold Down Forces									
Wt. Reduction		0.60	0.60	0.60	0.60	0.60	0.60	-	Wt. Reduction		0.60	0.60	0.60	0.60	0.60	0.60	-
T _R accum	k	0.87	0.48	0.56	0.56	-	-	-	T _R accum	k	1.48	0.81	0.84	0.84	0.62	0.53	-
HD Offset	ft	-	-	-	-	-	-	-	HD Offset	ft	-	-	-	-	-	-	-
HD Force	k	0.88	1.11	1.20	1.20	-	-	-	HD Force	k	1.80	1.21	1.26	1.26	0.61	0.67	-
HD Capacity	k	3.08	3.08	3.08	3.08	-	-	-	HD Capacity	k	3.08	3.08	3.08	3.08	3.08	3.08	-
Hold Down Type		Ⓡ	Ⓡ	Ⓡ	Ⓡ	Ⓡ	Ⓡ	-	Hold Down Type		Ⓡ	Ⓡ	Ⓡ	Ⓡ	Ⓡ	Ⓡ	-
Project: Smith-Cutright Residence Addition & Remodel								By: DLS									
Location: LF-1								Job No.: 21-028									
Client: Laura Smith & David Cutright								Last Update: 24-Apr-20									
Wood Shear Wall Design Aid								Comments:									



Force Transfer Around Openings Calculator

TWO OPENINGS

The force transfer around openings (FTAO) method of shear wall analysis is an approach that aims to reinforce the wall such that it performs as if there was no opening. This approach lends certain advantages over segmented shear walls: more versatility, because it allows for narrower wall segments while still meeting the height-to-width ratios and, often, fewer required hold-downs.

Project Information

Code:	2018 IBC	Date:	
Designer:	DLS		
Client:	Laura Smith & David Cutright		
Project:	21-028 Smith-Cutright Residence Addition & Remodel		
Wall Line:	TF-1 1st		

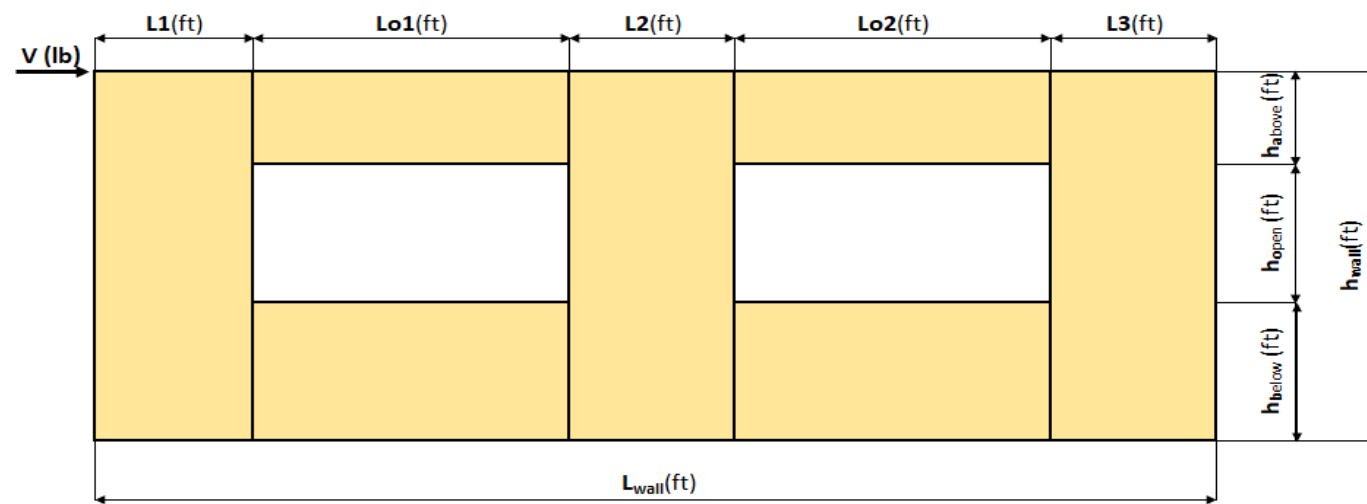

Shear Wall Calculation Variables

V	1830 lbf	Opening 1		Opening 2		Adj. Factor Method = 2bs/h	
L1	2.33 ft	ha1	1.08 ft	ha2	1.08 ft	Wall Pier Aspect Ratio	
L2	3.00 ft	ho1	4.00 ft	ho2	4.00 ft	P1=ho1/L1=	1.72
L3	2.17 ft	hb1	3.00 ft	hb2	3.00 ft	P2=ho2/L2=	1.33
hwall	8.08 ft	Lo1	6.00 ft	Lo2	10.00 ft	P3=ho3/L3=	1.84
Lwall	23.50 ft						Adj. Factor

1. Hold-down forces: $H = Vh_{wall}/L_{wall}$ = 629 lbf

2. Unit shear above + below opening
 First opening: $va1 = vb1 = H/(ha1+hb1) = 154$ plf
 Second opening: $va2 = vb2 = H/(ha2+hb2) = 154$ plf

3. Total boundary force above + below openings
 First opening: $O1 = va1 \times (Lo1) = 925$ lbf
 Second opening: $O2 = va2 \times (Lo2) = 1542$ lbf

4. Corner forces
 $F1 = O1(L1)/(L1+L2) = 404$ lbf
 $F2 = O1(L2)/(L1+L2) = 521$ lbf
 $F3 = O2(L2)/(L2+L3) = 895$ lbf
 $F4 = O2(L3)/(L2+L3) = 647$ lbf

5. Tributary length of openings
 $T1 = (L1 \cdot Lo1)/(L1+L2) = 2.62$ ft
 $T2 = (L2 \cdot Lo1)/(L1+L2) = 3.38$ ft
 $T3 = (L2 \cdot Lo2)/(L2+L3) = 5.80$ ft
 $T4 = (L3 \cdot Lo2)/(L2+L3) = 4.20$ ft

6. Unit shear beside opening
 $V1 = (V/L)(L1+T1)/L1 = 166$ plf
 $V2 = (V/L)(T2+L2+T3)/L2 = 316$ plf
 $V3 = (V/L)(T4+L3)/L3 = 228$ plf
 Check $V1 \cdot L1 + V2 \cdot L2 + V3 \cdot L3 = V?$ = 1830 lbf **OK**

7. Resistance to corner forces
 $R1 = V1 \cdot L1 = 386$ lbf
 $R2 = V2 \cdot L2 = 948$ lbf
 $R3 = V3 \cdot L3 = 496$ lbf

8. Difference corner force + resistance
 $R1 - F1 = -19$ lbf
 $R2 - F2 - F3 = -467$ lbf
 $R3 - F4 = -151$ lbf

9. Unit shear in corner zones
 $vc1 = (R1 - F1)/L1 = -8$ plf
 $vc2 = (R2 - F2 - F3)/L2 = -156$ plf
 $vc3 = (R3 - F4)/L3 = -70$ plf

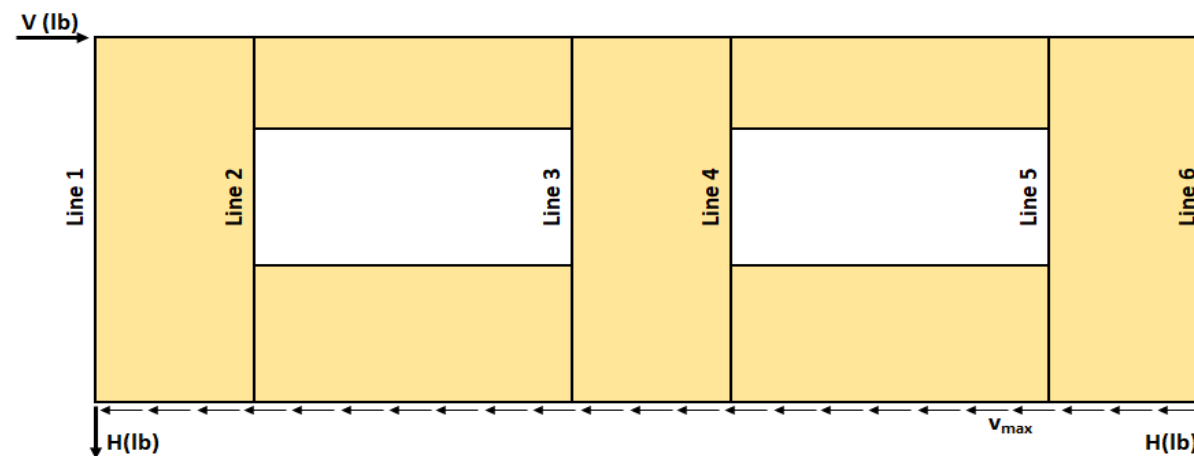

Check Summary of Shear Values for Two Openings

Line 1: $vc1(ha1+hb1)+V1(ho1)=H?$			-33	662	629 lbf
Line 2: $va1(ha1+hb1)-vc1(ha1+hb1)-V1(ho1)=0?$	629	-33		662	0
Line 3: $vc2(ha1+hb1)+V2(ho1)-va1(ha1+hb1)=0?$	-635	1265		629	0
Line 4: $va2(ha2+hb2)-V2(ho2)-vc2(ha2+hb2)=0?$	629	1265	-635		0
Line 5: $va2(ha2+hb2)-vc3(ha2+hb2)-V3(ho2)=0?$	629	-285		914	0
Line 6: $vc3(ha2+hb2)+V3(ho2)=H?$		-285		914	629 lbf

Design Summary*

Req. Sheathing Capacity	316 plf	4-Term Deflection	0.411 in.	3-Term Deflection	0.343 in.
Req. Strap Force	895 lbf	4-Term Story Drift %	0.017 %	3-Term Story Drift %	0.014 %
Req. HD Force	629 lbf		See Page 2		See Page 3
Req. Shear Wall Anchorage Force	78 plf				

*The Design Summary assumes that the shear wall is designed as blocked.

Shear Wall Deflection Calculation Variables

Induced Shear Load $V_{induced}$:	3050 (lbf)
------------------------------------	------------

Project Information

Code:	2018 IBC	Date:	
Designer:	DLS		
Client:	Laura Smith & David Cutright		
Project:	21-028 Smith-Cutright Residence Addition & Remodel		
Wall Line:	TF-1 1st		

Sheathing:	
OSB	Sheathing Material
7/16	Performance Category
APA Rated Sheathing	Grade
	Gt Override
	Ga Override

Wood End Post Values:	
Species:	DF-L
E:	1.20E+06 (psi)
Dimensions:	Qty Stud Size
	2 2x6
A:	16.5 (in. ²)
A Override:	(in. ²)

Nail Type:	8d common (penny weight)	
	Pier 1	Pier 3
Nail Spacing:	6	6 (in.)
HD Capacity:	3075	3075 (lbf)
HD Deflection:	0.088	0.088 (in.)

Four-Term Equation Deflection Check

$$\Delta = \frac{8vh^3}{EAb} + \frac{vh}{Gt} + 0.75he_n + d_a \frac{h}{b} \quad \text{(Equation 23-2)}$$

	Pier 1-L	Pier 1-R	Pier 2-L	Pier 2-R	Pier 3-L	Pier 3-R	
Sheathing:	7/16	7/16	7/16	7/16	7/16	7/16	
Nail:	8d common	8d common	8d common	8d common	8d common	8d common	
V _{induced} :	276	276	527	527	381	381	(plf)
E:	1.20E+06	1.20E+06	1.20E+06	1.20E+06	1.20E+06	1.20E+06	(psi)
h:	8.08	5.08	5.08	5.08	5.08	8.08	(ft)
A:	16.5	16.5	16.5	16.5	16.5	16.5	(in. ²)
Gt:	83,500	83,500	83,500	83,500	83,500	83,500	(lbf/in.)
Nail Spacing:	6	6	6	6	6	6	(in.)
V _n :	138	138	263	263	190	190	(plf)
e _n :	0.0131	0.0131	0.0925	0.0925	0.0347	0.0347	(in.)
b:	2.33	2.33	3.00	3.00	2.17	2.17	(ft)
HD Capacity:	3075	3075	3075	3075	3075	3075	(lbf)
HD Defl:	0.088	0.088	0.088	0.088	0.088	0.088	(in.)

Check Total Deflection of Wall System

Pier 1 (left)				Pier 1 (right)			
Term 1	Term 2	Term 3	Term 4	Term 1	Term 2	Term 3	Term 4
Bending	Shear	Fastener	HD-1	Bending	Shear	Fastener	HD-2
0.025	0.027	0.079	0.221	0.006	0.017	0.050	0.087
Sum			0.353	Sum			0.160
Pier 2 (left)				Pier 2 (right)			
Term 1	Term 2	Term 3	Term 4	Term 1	Term 2	Term 3	Term 4
Bending	Shear	Fastener	HD-1	Bending	Shear	Fastener	HD-2
0.009	0.032	0.352	0.130	0.009	0.032	0.352	0.130
Sum			0.523	Sum			0.523
Pier 3 (left)				Pier 3 (right)			
Term 1	Term 2	Term 3	Term 4	Term 1	Term 2	Term 3	Term 4
Bending	Shear	Fastener	HD-1	Bending	Shear	Fastener	HD-2
0.009	0.023	0.132	0.130	0.037	0.037	0.210	0.328
Sum			0.294	Sum			0.612

Total Defl.	0.411 (in.)
	0.0170 %drift

Three-Term Equation Deflection Check

$$\delta_{sw} = \frac{8vh^3}{EAb} + \frac{vh}{1000G_a} + \frac{h\Delta_a}{b} \quad \text{(4.3-1)}$$

	Pier 1-L	Pier 1-R	Pier 2-L	Pier 2-R	Pier 3-L	Pier 3-R	
Sheathing:	7/16	7/16	7/16	7/16	7/16	7/16	
Nail:	8d common	8d common	8d common	8d common	8d common	8d common	
V _{induced} :	276	276	527	527	381	381	(plf)
E:	1.20E+06	1.20E+06	1.20E+06	1.20E+06	1.20E+06	1.20E+06	(psi)
h:	8.08	5.08	5.08	5.08	5.08	8.08	(ft)
A:	16.5	16.5	16.5	16.5	16.5	16.5	(in. ²)
G _a :	15.0	15.0	15.0	15.0	15.0	15.0	(kips/in.)
b:	2.33	2.33	3.00	3.00	2.17	2.17	(ft)
HD Capacity:	3075	3075	3075	3075	3075	3075	(lbf)
HD Defl:	0.088	0.088	0.088	0.088	0.088	0.088	(in.)

Check Total Deflection of Wall System

Pier 1 (left)			Pier 1 (right)		
Term 1	Term 2	Term 3	Term 1	Term 2	Term 3
Bending	Shear	Fastener	Bending	Shear	Fastener
0.025	0.149	0.221	0.006	0.093	0.087
Sum		0.395	Sum		0.187
Pier 2 (left)			Pier 2 (right)		
Term 1	Term 2	Term 3	Term 1	Term 2	Term 3
Bending	Shear	Fastener	Bending	Shear	Fastener
0.009	0.178	0.130	0.009	0.178	0.130
Sum		0.317	Sum		0.317
Pier 3 (left)			Pier 3 (right)		
Term 1	Term 2	Term 3	Term 1	Term 2	Term 3
Bending	Shear	Fastener	Bending	Shear	Fastener
0.009	0.129	0.130	0.037	0.205	0.328
Sum		0.268	Sum		0.570

Total Defl.	0.343 (in.)
	0.0141 %drift

Comment: The 3-term equation is calibrated to be approximately equal to 4-term equation at 1.4*ASD capacity.